



## Configuration design, energy management and experimental validation of a novel series-parallel hybrid electric transit bus\*

Wei-wei XIONG<sup>†</sup>, Yong ZHANG, Cheng-liang YIN

(Institute of Automotive Engineering, Shanghai Jiao Tong University, Shanghai 200240, China)

<sup>†</sup>E-mail: wexiong@yahoo.com.cn

Received July 20, 2008; Revision accepted Nov. 3, 2008; Crosschecked July 24, 2009

**Abstract:** This paper aims to present the configuration design approach and the energy management strategy (EMS) of a series-parallel hybrid electric transit bus (SPHEB) jointly developed by Shanghai Automotive Industry Co. Ltd. (SAIC) and Shanghai Jiao Tong University (SJTU), China. A major feature of this SPHEB is that a novel manual transmission is designed to switch the powertrain configuration between series and parallel types. To reduce the fuel consumption as well as sustain the battery state of charge, an EMS including seven energy flow modes is designed and applied to this SPHEB. Governed by this EMS, the engine is maintained to operate in high efficiency regions. The experimental test carried on the transit bus city driving cycle is described and analyzed. The experimental results demonstrate the technical feasibility and fuel economy of this approach.

**Key words:** Series-parallel hybrid bus, Powertrain configuration, Energy management, Experimental validation

**doi:**10.1631/jzus.A0820556

**Document code:** A

**CLC number:** U469.72

### INTRODUCTION

Because of environmental and energy issues, more and more research has focused on new generation clean vehicles recently, such as electric vehicles (EVs), hybrid electric vehicles (HEVs) and fuel cell electric vehicles (FCEVs). Limited by the lifetime, power density and purchasing cost of batteries and fuel cells, the development of EV and FCEV is slow despite having the most environmental potential in the future. The HEV uses small battery packs and inherits a downsized internal combustion engine (ICE) from the conventional vehicle, and it is thereby considered as an in-between product. Despite the fact that it is questionable whether some hybrid vehicles present better characteristics in terms of running and purchasing costs, their development has been accelerated recently. There exist three types of HEVs:

series, parallel and series-parallel types. In the series hybrid electric vehicle (SHEV), the drive system is solely powered by the electric motor that draws its power from the on-board battery unit which is charged by the vehicle engine (Fontaras *et al.*, 2008) (Fig.1). The parallel hybrid electric vehicle (PHEV) has a simple structure with one engine and one electric motor. Both the engine and the electric motor can deliver power in parallel to drive the wheels unless the electric motor is simultaneously charging the battery (Won *et al.*, 2005; Poursamad and Montazeri, 2008). The series hybrid system is more suitable for city driving cycle conditions, while during highway driving conditions parallel hybrid behavior is preferable (Pérez *et al.*, 2004; Harmon *et al.*, 2005).

The series-parallel hybrid electric vehicle (SPHEV) combines a series hybrid system with a parallel hybrid system to extract the benefits of both systems. It is more suitable for various driving cycle conditions. For example, during the transit bus driving cycle, which features frequent urban stop and go traffic, the SPHEV can be driven by motor alone to

\* Project (No. 2006AA11A127) supported by the Hi-Tech (863) Research and Development Program of China

avoid increasing the fuel consumption and pollutant emissions at low-speed, and then runs as a parallel HEV at high-speed. The series configuration is also favorable for recovering the kinetic energy during frequent brake operations. Of course, SPHEVs also inherit some of the disadvantages of their parent configurations, such as the high cost of electrical power installation from series hybrid electric configuration and the complexity of the parallel configuration. In recent decades, the SPHEV caught peoples' attention because of its advantages (Ohshima *et al.*, 2000; Inada *et al.*, 2002; Sciarretta *et al.*, 2004; Cao and Chen, 2005; Miller and Everett, 2005; Syed *et al.*, 2006), but fewer SPHEV have been introduced to the market. Especially in China, there is room for the development of the SPHEV despite research into HEVs launched ten years ago.

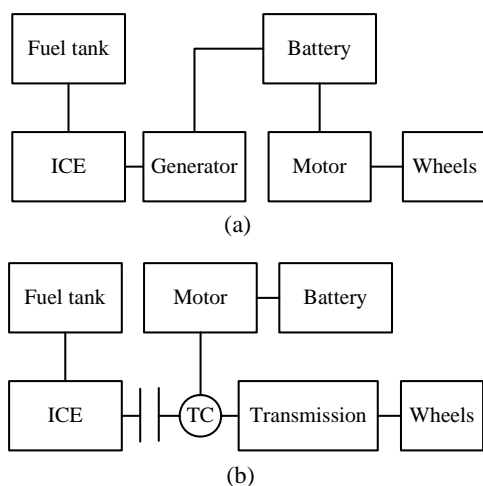

**Fig.1 Schemes of the SHEV (a) and PHEV (b)**  
TC: torque coupler

The parameter matching method of a post-transmission coupled series-parallel hybrid electric transit bus (SPHEB), which is jointly developed by Shanghai Automotive Industry Co. Ltd. (SAIC) and Shanghai Jiao Tong University (SJTU), China (Xiong *et al.*, 2008a). For this SPHEB, a novel manual transmission is used to switch the configuration between series type and parallel type. In this paper, the novel transmission scheme is presented. The vehicle specifications and the control strategy are described. The experimental tests are also carried out on the city driving cycle. The results demonstrate the validity of the control strategy for the purpose of

reducing the fuel consumption as well as sustaining the state of charge (SOC).

## POWERTRAIN SYSTEM CONFIGURATION

The novel hybrid powertrain system was retrofitted to a conventional bus (Fig.2). This bus is a 12 m, 12 t, 4×2 class transit bus modeled SWB6116 from SAIC, China. The powertrain system designed by our group takes the place of its original powertrain system; meanwhile the accessory system is updated to satisfy the requirements of an HEV.

As shown in Fig.3, to configure a series-parallel type powertrain, two electric motors which are the integrated starter/generator (ISG) and the traction motor (TM) are introduced into the system. The ICE and the ISG are located upstream of the clutch; the crankshaft of the engine is directly linked with the rotor of the ISG. The TM is placed downstream of the transmission; it is linked to the output shaft of the transmission via a torque coupler (TC), and then connected to the wheels through the propeller shaft and differential. As shown in Fig.4, the TC is an in-house mechanical reduction gear assembly. It increases the torque transmitted through it; as a result the TM is able to be reduced in size. Furthermore, it increases the speed of the motor, and allows the traction motor to spin in its optimum efficiency range around 4000~5000 r/min, corresponding to the normal vehicle speed range under city driving cycle conditions.



**Fig.2 Photography of the SPHEB**

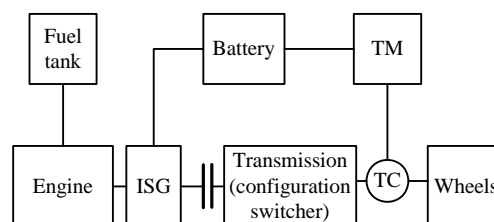

**Fig.3 Configuration of the SPHEB**

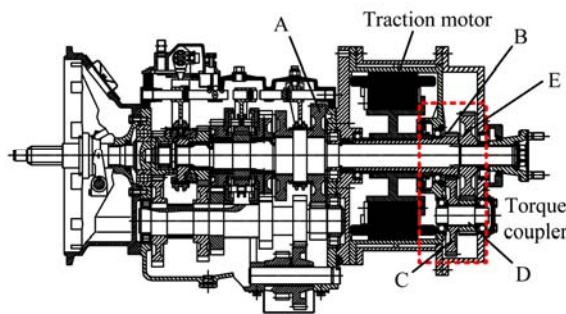

A: the first gear of transmission; B: the first gear of TC; C: the second gear of TC; D: the third gear of TC; E: the fourth gear of TC

**Fig.4 Configuration of the manual transmission and the TM assembly**

We have developed two types of SPHEBs based on two types of transmission, which are the manual mechanical transmission (MT) and the automatic mechanical transmission (AMT). In this study, the SPHEB employing a novel manual transmission is presented. In this SPHEB, the original manual clutch is also retained. Although the clutch can cut off the mechanical power flow path for a series configuration, it needs to be manually activated all the time. It is infeasible to decouple the engine by disengaging the clutch to drive the vehicle in series. Therefore, a novel manual transmission is designed for switching the vehicle configuration between series type and parallel type. The configuration of the manual transmission is shown in Fig.4. The first gear, which is indicated by the letter "A" in Fig.4, is replaced by a disk-shaped metal block without gear teeth. It cannot be coupled with any other gears. Therefore, when the transmission is shifted to the original first gear position, the driveline from the engine to the propeller shaft is disconnected, to obtain a series type configuration, and then the vehicle runs as an SHEV. Otherwise, the electric motors couple the engine in parallel and the vehicle is then driven as a PHEV.

The specifications of the vehicle and its components are listed in Table 1. A Cummins ISB<sup>e</sup>180 conventional direct injection diesel engine was selected as fuel converter. The electric motors, including the ISG and the TM, are permanent magnet synchronous alternating current (AC) type. A 60 A·h, 336 V Nickel Metal Hydride (NiMH) battery pack is employed as the power storage. Since the first gear set of the original 5-gear manual transmission is displaced,

the new transmission has 4 transmissive forward gears corresponding to the original 2nd, 3rd, 4th and 5th gears. The original 1st gear is operated as a series-parallel configuration switcher.

**Table 1 Specifications of vehicle and components**

Parameter	Specification
<b>Vehicle</b>	
Curb weight (kg)	12 000
Frontal area (m <sup>2</sup> )	7.5
Aerodynamic coefficient	0.62
Wheel radius (m)	0.508
<b>Engine</b>	
Peak power (kW)	135
Peak torque (N·m)	550
Speed range (r/min)	0~2500
Emission	Euro. 3
<b>TM</b>	
Peak power (kW)	80
Continuous power (kW)	40
Peak torque (N·m)	350
<b>ISG</b>	
Peak power (kW)	30
Continuous power (kW)	20
Peak torque (N·m)	290
<b>Battery</b>	
Type	NiMH
Power capability (A·h)	60
Rated voltage (V)	336
Transmission gear ratios	1st: NA; 2nd: 3.78; 3 rd: 2.168; 4th: 1.442; 5th: 1; R: 6.533
TC speed ratio	4

NA: no answer; R: reverse

## ENERGY FLOW MANAGEMENT STRATEGY

A type of energy management strategy (EMS) for this SPHEB is presented. Based on the energy flow paths shown in Fig.5, seven modes are embodied in the EMS:

### (1) Motor alone mode

The requested torque ( $T_{REQ}$ ) is directly delivered to the TM, the engine and the ISG are shut off, and then the vehicle is driven by the TM alone.

### (2) Series charge mode

If the EMS switches to the series charge mode, the ISG and the ICE should be combined as a generator set to charge the battery and power the TM after

the ICE was started. In this mode, the desired charge torque ( $-T_{CH}$ ) is commanded from the ISG, and a close-loop control is introduced to govern the engine speed. The requested torque is also commanded from the TM to drive the bus.

(3) Engine alone mode

The ISG and the TM are all shut off, and the engine propels the bus alone like a conventional bus.

(4) Parallel charge mode

The engine provides torque to drive the bus; meanwhile the TM acts as a generator to absorb part of the power from the engine to charge the battery. Of course, the ISG can also generate power to charge the battery, but for the purpose of simplifying the EMS and preventing the overheating of the air-cooled ISG, the TM is set to work prior to the ISG in this mode.

(5) Motor assist mode

As to this mode, both the engine and the TM will drive the bus simultaneously to satisfy the driver's request.

(6) Stand charge mode

When the EMS switches to this mode, the engine combines the ISG as a generator set, and the TM is shut off. This mode occurs if the conditions below are all satisfied:

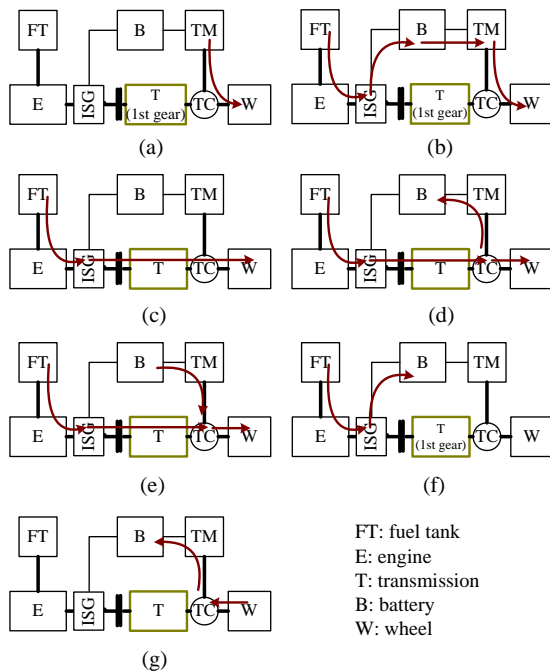

Fig. 5 Energy flow paths under seven modes. (a) Motor alone; (b) Series charge; (c) Engine alone; (d) Parallel charge; (e) Motor assist; (f) Stand charge; (g) Regenerative brake

(a) Vehicle stops but is not parking braked and the key is on;

(b) SOC is below a certain value ( $C_{SOC}$ ) which is higher than the lowest SOC allowed ( $L_{SOC}$ ), but lower than the highest SOC allowed ( $H_{SOC}$ );

(c) Engine has already been fired up or the SOC is too low;

(d) Transmission is set in the 1st gear.

(7) Regenerative brake mode

Regenerative brake mode is a feature usually employed by HEVs to improve fuel economy. When the brake pedal is depressed, the TM acts as a generator to capture the kinetic power to reduce brake energy losses.

To fulfill the objectives of the EMS, the torque distribution principles, including the SOC sustaining regulations shown in Fig.6, are used to govern the energy flow. Note that the motor alone mode and series charge mode only occur when the transmission is left in the first gear (series configuration), and other modes are available when the transmission is not in the first gear. The gear position (GP) controlled by the driver is thereby considered as an input variable of the EMS, which is different from the EMS of an HEV equipped with an automatic transmission. The engine

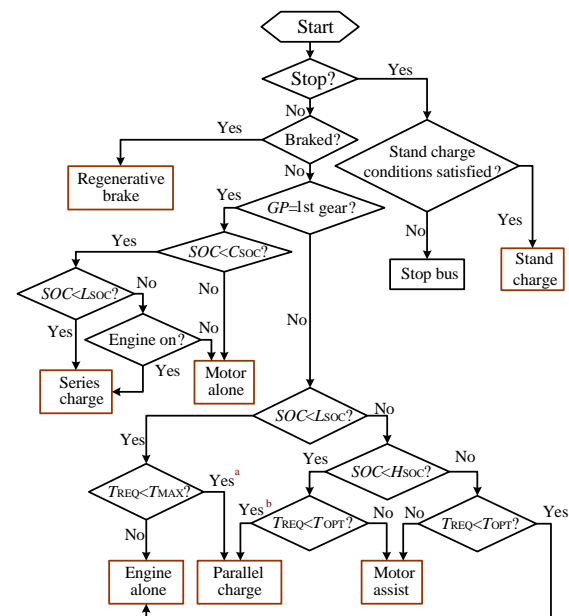

GP: transmission gear position;  $L_{SOC}$ : the lowest battery state of charge allowed;  $H_{SOC}$ : the highest battery state of charge allowed;  $C_{SOC}$ : SOC threshold for series/stand charge control;  $T_{OPT}$ : optimal engine operation torque versus engine angular speed;  $T_{CH}$ : desired charge torque

Fig. 6 Energy flow control strategy of the SPHEB

idling operation is eliminated in this SPHEB. In order to reduce the engine stop-start operations, there is a criterion regarding engine operation in the series charge mode. When the powertrain configuration is switched from parallel (engine on) to series, and while the SOC is higher than  $L_{SOC}$  but lower than  $C_{SOC}$ , the series charge mode should also be commanded to avoid shutting down the engine immediately.

The objective of the energy management is to minimize the fuel consumption as well as to sustain the battery state of charge while ensuring the drive performances. As for this EMS, the engine torque is maintained at an optimal torque in most conditions. The torque  $T_{OPT}^*$ , indicated in Fig.7, where the Brake Specific Fuel Consumptions (BSFCs) are shown, is a theoretical optimal torque for higher fuel conversion efficiency and the avoidance of fast engine speed fluctuation (Chau and Wong, 2002; Lin et al., 2008). However, in this case the energy from the ICE is insufficient to both recharge the battery and drive the vehicle while the engine is tracking the line  $T_{OPT}^*$  under urban driving cycle conditions. The underlying reason is that the electric propulsion and electrified accessories increased battery power consumption. Therefore, this optimal torque is tuned from  $T_{OPT}^*$  to a higher torque  $T_{OPT}$  to recuperate the battery power and then prevent the depletion of the charge.

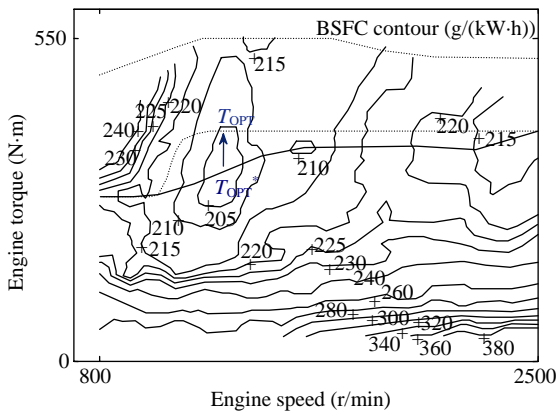

Fig.7 Optimal operation torque of the engine

As mentioned above, one goal of the energy management is to satisfy the driver's request. The energy (torque) relationships of this SPHEB can be expressed as follows:

$$T_{REQ} = \begin{cases} T_{TM}, & \text{if } GP = 1\text{st gear;} \\ T_E + T_{ISG} + T_{TM}, & \text{if } GP \neq 1\text{st/neutral gear,} \end{cases} \quad (1)$$

where  $T_{REQ}$  is the requested torque;  $T_{TM}$  is the TM torque;  $T_E$  is the engine torque;  $T_{ISG}$  is the ISG torque.

To fulfill the objectives, the torque distribution algorithms for each operation mode given in Table 2 are used. If the SOC drops below the lowest limit and the driver requests a torque beyond the capability of the engine, the engine should output its maximum torque  $T_{MAX}$  but the electric motors should shut down. In this case, the kinetic performance is sacrificed to prevent the depletion of the battery. Therefore, it is necessary to minimize this possibility, which is also one of the reasons for adopting the SOC threshold  $C_{SOC}$  that is higher than the lowest limit, to trigger the series/stand charge operation.

Table 2 Torque distribution algorithms for each operation mode

Mode	Algorithm
Motor alone	$T_E=0; T_{ISG}=0; T_{TM}=T_{REQ}$
Series charge	$T_E=T_{CH}; T_{ISG}=-T_{CH}; T_{TM}=T_{REQ}$
Engine alone	$T_E=T_{REQ}; T_{ISG}=0; T_{TM}=0$
Parallel charge	$T_E=T_{MAX}^a (T_E=T_{OPT}^b); T_{ISG}=0;$ $T_{TM}=T_{REQ}-T_E$
Motor assist	$T_E=T_{OPT}; T_{ISG}=0; T_{TM}=T_{REQ}-T_{OPT}$
Stand charge	$T_E=T_{CH}; T_{ISG}=-T_{CH}; T_{TM}=0$
Regenerative brake	$T_E=0; T_{ISG}=0; T_{TM}=T_{REQ}$

<sup>a</sup> For the condition marked with superscript "a" in Fig.6; <sup>b</sup> For the condition marked with superscript "b" in Fig.6

## EXPERIMENTAL VALIDATION

A road test is presented. The driving cycle used for the fuel economy evaluation is the Chinese Transit Bus City Driving Cycle (CTBCDC) recommended in the Chinese standard GB/T 19754-2005 (2005). The characteristic parameters of this driving cycle are listed in Table 3. The experimental configuration shown in Fig.8 was presented in (Xiong et al., 2008b). A CAN-based data acquisition system, which employs a Vector<sup>TM</sup> CANcaseXL device, was developed to monitor and store the test data. One channel of this device is connected into the vehicle control network to collect information about the engine, the ISG, the TM, the battery and the transmission, etc. The other channel is linked to a frequency capture and pulse counter module to acquire the signal from the on-board speed radar and fuel meter.



**Table 3 Driving cycle characteristic parameters**

Parameter	Value
Time (s)	1314
Distance (km)	5.8
Maximum speed (km/h)	60.0
Average speed (km/h)	15.9
Maximum acceleration ( $m/s^2$ )	0.914
Maximum deceleration ( $m/s^2$ )	-1.543
Average acceleration ( $m/s^2$ )	0.32
Average deceleration ( $m/s^2$ )	-0.47
Idle time (%)	29.0

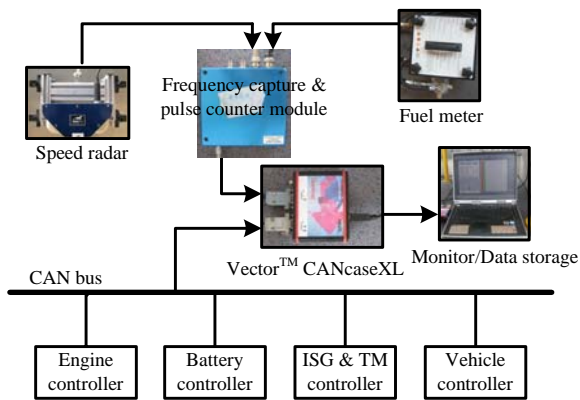
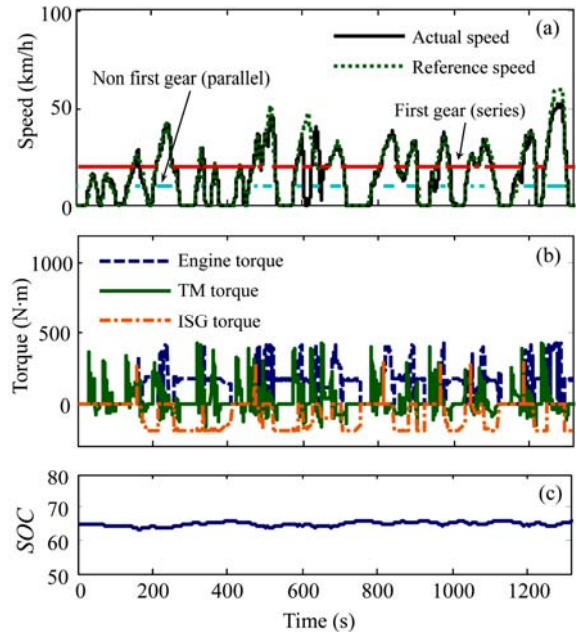

**Fig.8 Experimental configuration**

During the test the vehicle is loaded at 3.5 t. In this case it is proposed to switch the powertrain configuration to a speed around 20 km/h corresponding to an economy engine speed when the transmission is set in the 2nd gear. The configuration type (transmission gear position), the driving cycle profile (reference speed) and the actual speed are all shown in Fig.9a. Meanwhile, the torque of the engine, TM and ISG are given in Fig.9b. Fig.9c indicates that the SOC can be sustained in a normal range.

Fig.10 shows a detail of the results. The regions of each operation mode are also highlighted by letters. Respectively, letter “H” represents the point of engine start at which the ISG acts as a starter to raise the engine speed quickly; letter “I” represents the point at which the transmission is shifting. The corresponding relationship between the letters and the modes are: A: motor alone; B: series charge; C: engine alone; D: parallel charge; E: motor assist; F: stand charge; G: regenerative brake.

The actual engine operation points in the speed-torque frame are shown in Fig.11. It can be



**Fig.9 Test results of speed and gear position (configuration type) (a), torque distribution (b) and transient SOC (c) under CTBCDC**

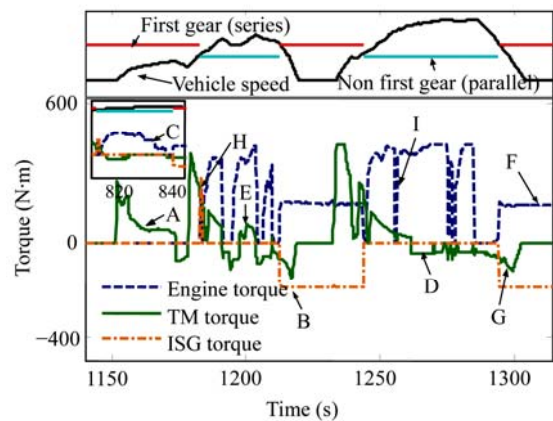

**Fig.10 Modes indicated in detail**

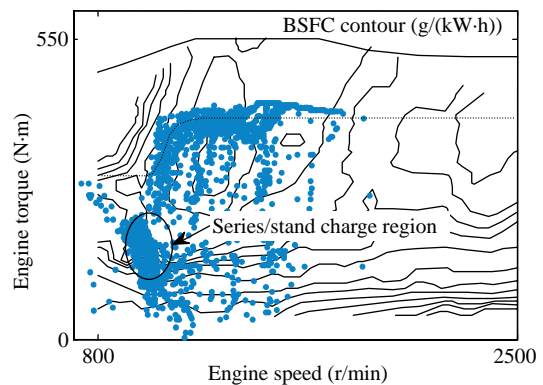

**Fig.11 Engine operation points**

seen that the engine's output can be maintained around the predefined optimal torque under the parallel configuration. The bottom left part of the figure is the operation region of the series/stand charge.

As to a vehicle with manual transmission, the driver's operations will affect the fuel economy in depth. The test results, given in Table 4, indicate that an average fuel consumption reduction of 21.3% can be achieved compared to a fuel consumption of 40.0 L/100 km with a conventional diesel bus. In addition, the driver performances of this SPHEB are given in Table 5. At present, this vehicle is undergoing a fuel economy/emission optimization and endurance test. We optimize the EMS as well as its control parameters through a numerical experimental approach and evaluate its performance with a road test.

**Table 4 Fuel consumptions under CTBCDC**

	Fuel consumption (L/100 km)	Reduction (%)
Optimistic case	29.0	27.5
Pessimistic case	33.9	15.3
Base (average) case	31.5	21.3

**Table 5 Drive performances of the SPHEB**

Performance	Value
Max speed (km/h)	>80
0~50 km/h time (s)	<25
Grade ability (%)	>20

## CONCLUSION

A series-parallel hybrid electric powertrain employing a novel manual transmission is presented. The engine-optimization-based EMS, which includes seven energy flow control modes, is also given and analyzed. The hybrid bus is road-tested in a city transit bus driving cycle. The results show that the fuel consumption can be reduced by 21.3% on average, compared with that of a conventional bus. In addition, the drive performances are ensured and the battery charge is sustained within a normal range. These advantages identify the technical and economical feasibility of this approach.

Such a manual-switched series-parallel powertrain is a low-cost system. Whereas the hybrid con-

figuration can be switched automatically using an automatic transmission, which also helps to reduce the driver's workload. The authors have also applied much effort in designing and developing an automated heavy-duty series-parallel powertrain. However, the cost advantage of the automatic system is being analyzed. In addition, the in-depth optimization of component size and control parameters of this series-parallel powertrain is also important issues that need further study.

## References

- Cao, M., Chen, J., 2005. HEV maximum power performance simulation and duty cycle generation. *International Journal of Vehicle Design*, **38**(1):42-57. [doi:10.1504/IJVD.2005.006604]
- Chau, K.T., Wong, Y.S., 2002. Overview of power management in hybrid electric vehicles. *Energy Conversion and Management*, **43**(15):1953-1968. [doi:10.1016/S0196-8904(01)00148-0]
- Fontaras, G., Pistikopoulos, P., Samaras, Z., 2008. Experimental evaluation of hybrid vehicle fuel economy and pollutant emissions over real-world simulation driving cycles. *Atmospheric Environment*, **42**(18):4023-4035 [doi:10.1016/j.atmosenv.2008.01.053]
- GB/T 19754-2005, 2005. Test Methods for Energy Consumption of Heavy-duty Hybrid Electric Vehicle. General Administration of Quality Supervision, Inspection and Quarantine of the People's Republic of China.
- Harmon, F.G., Frank, A.A., Joshi, S.S., 2005. The control of a parallel hybrid-electric propulsion system for a small unmanned aerial vehicle using a CMAC Neural Net Work. *Neural Networks*, **18**(5-6):772-780. [doi:10.1016/j.neunet.2005.06.030]
- Inada, E., Matsuo, I., Tahara, M., Abe, T., 2002. Development of a High Performance Hybrid Electric Vehicle Tino Hybrid. EVS17, Montreal, Canada.
- Lin, X., Pan, S.X., Wang, D.Y., 2008. Dynamic simulation and optimal control strategy for a parallel hybrid hydraulic excavator. *Journal of Zhejiang University SCIENCE A*, **9**(5):624-632. [doi:10.1631/jzus.A071552]
- Miller, J.M., Everett, M., 2005. An Assessment of Ultracapacitors as the Power Cache in Toyota THS-II, GM-Allison AHS-2 and Ford FHS Hybrid Propulsion Systems. APEC, 20th Annual IEEE, **1**:481-490. [doi:10.1109/APEC.2005.1452980]
- Ohshima, K., Kondo, K., Ibaraki, R., Matsui, H., 2000. Development of transaxle for hybrid vehicle. *JSAE Review*, **21**(3):343-347. [doi:10.1016/S0389-4304(00)00047-3]
- Poursamad, A., Montazeri, M., 2008. Design of genetic-fuzzy control strategy for a parallel hybrid electric vehicles. *Control Engineering Practice*, **16**(7):861-873. [doi:10.1016/j.conengprac.2007.10.003]
- Pérez, L.V., Bossio, G.R., Moitre, D., García, G.O., 2004. Optimization of power management in a hybrid electric

- vehicle using dynamic programming. *Mathematics and Computers in Simulation*, **73**:244-254. [doi:10.1016/j.matcom.2006.06.016]
- Sciarretta, A., Back, M., Guzzella, L., 2004. Optimal control of parallel hybrid electric vehicles. *IEEE Transactions on Control System Technology*, **12**(3):352-363. [doi:10.1109/TCST.2004.824312]
- Syed, F.U., Kuang, M.L., Czubay, J., Ying, H., 2006. Derivation and experimental validation of a power-split hybrid electric vehicle model. *IEEE Transactions on Vehicular Technology*, **55**(6):1731-1747. [doi:10.1109/TVT.2006.878563]
- Won, J.S., Langari, R., Ehsani, M., 2005. An energy management and charge sustaining strategy for a parallel hybrid vehicle with CVT. *IEEE Transaction on Control System Technology*, **13**(2):313-320. [doi:10.1109/TCST.2004.838569]
- Xiong, W.W., Shu, J., Zhang, Y., Yin, C.L., Jiang, J.F., Chen, Y.L., 2008a. Parameters matching for a series-parallel hybrid electric bus powertrain system. *Journal of Shanghai Jiao Tong University*, **42**(8):1324-1328 (in Chinese).
- Xiong, W.W., Zhang, Y., Shu, J., 2008b. Application of CAN-based distributed control network in series-parallel hybrid electric bus. *Automotive Engineering*, **30**(8):664-666 (in Chinese).