

Jadav Chandra Das, Debashis De, 2016. Quantum-dot cellular automata based reversible low power parity generator and parity checker design for nanocommunication. *Frontiers of Information Technology & Electronic Engineering*, 17(3):224-236. <http://dx.doi.org/10.1631/FITEE.1500079>

# Quantum-dot cellular automata based reversible low power parity generator and parity checker design for nanocommunication

**Key words:** QCA, Parity generator, Parity checker, Feynman gate, Nanocommunication, Power dissipation

Corresponding author: Debashis De

E-mail: [dr.debashis.de@gmail.com](mailto:dr.debashis.de@gmail.com)

 ORCID: <http://orcid.org/0000-0002-9688-9806>

# Achievements

- Design of reversible odd-parity generator, odd-parity checker, and nanocommunication architecture.
- For the first time, the proposed reversible circuits are realized in QCA.
- Quantum cost-based analysis of proposed reversible circuits and its corresponding QCA layouts.
- The proposed Feynman gate is compared with existing circuits in terms of area, delay, and cell count.
- The heat energy dissipated by the proposed designs is estimated.
- Under thermal randomness, the polarization of output cells is observed and the reliability of the circuits is measured.

# Proposed designs

## Proposed Parity Generator and Its QCA Layout

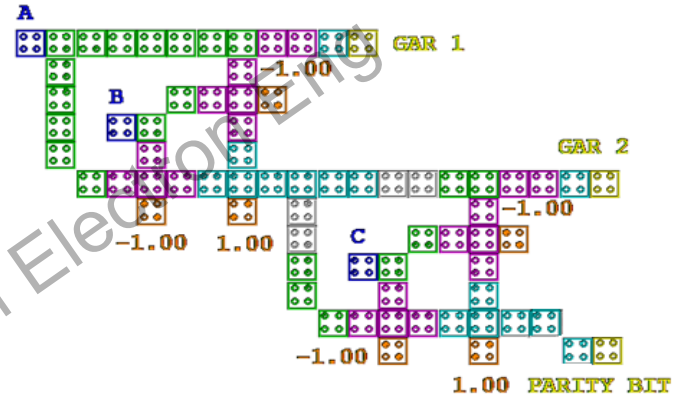
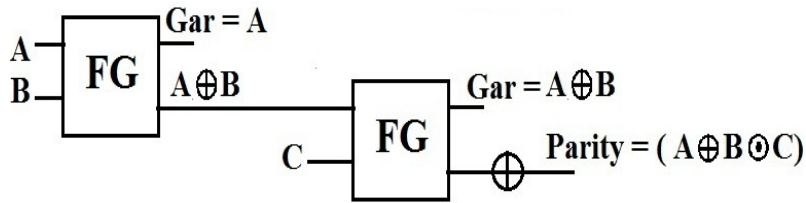

## Proposed Parity Checker and Its QCA Layout

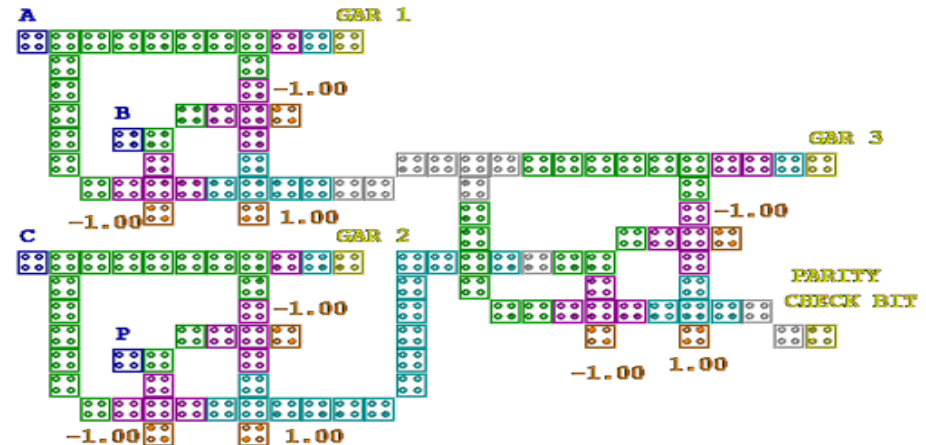
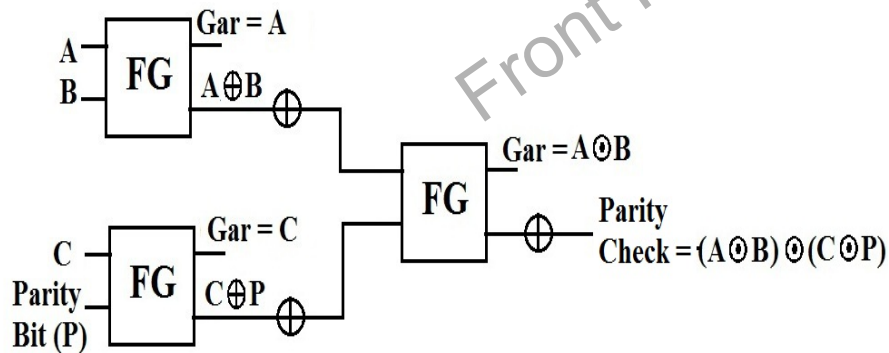

# Proposed nanocommunication circuit and its QCA layout

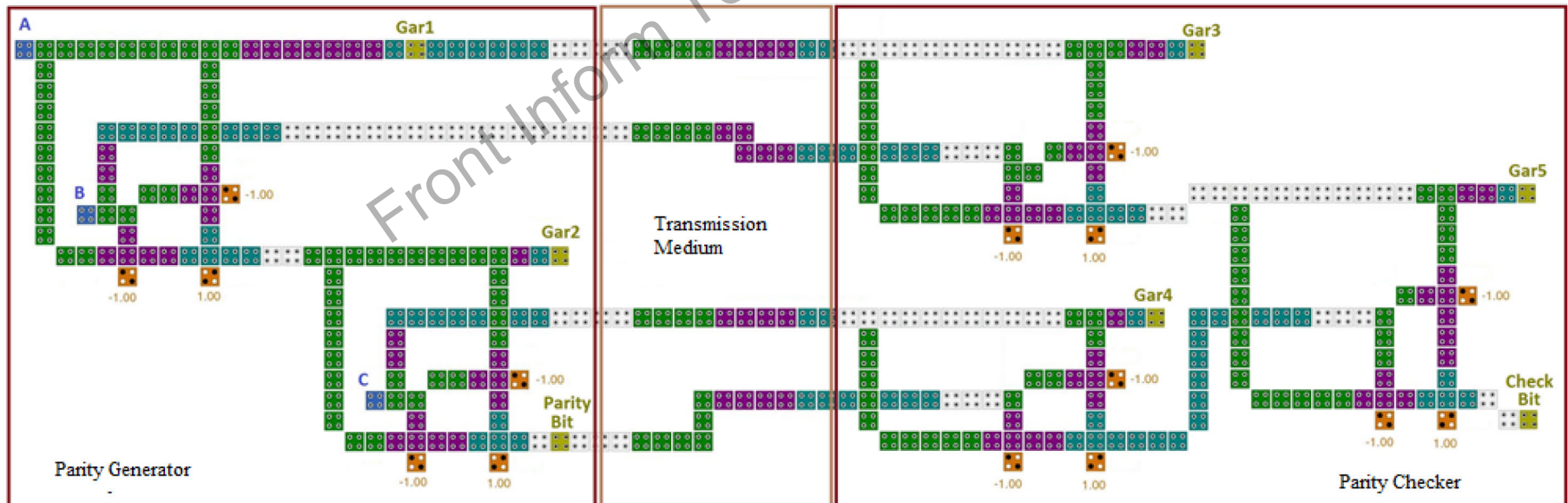
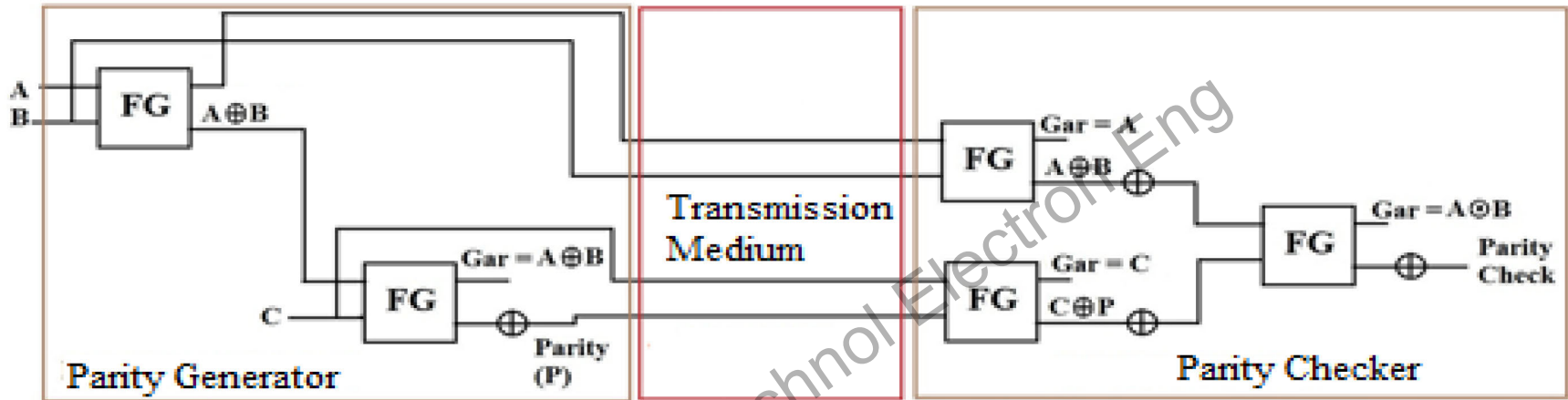

# Quantum cost

Proposed circuit	Quantum cost (traditional design)	Quantum cost (QCA layout)
Feynman gate	1	0.021
Reversible odd-parity generator	2	0.239
Reversible odd-parity checker	3	0.572
Nanocommunication circuit	5	1.916

# Power dissipation

Proposed QCA layout	Dissipation of power at $T = 2.0$ K			
	$\gamma = 0.25E_k$	$\gamma = 0.5E_k$	$\gamma = 0.75E_k$	$\gamma = 1.0E_k$
Feynman gate	105.1 meV	110.5 meV	118.2 meV	127.6 meV
Reversible odd-parity generator	293.8 meV	301.4 meV	313.9 meV	329.8 meV
Reversible odd-parity checker	426.5 meV	437.8 meV	456.2 meV	479.6 meV
Nanocommunication circuit	666.7 meV	692.8 meV	732.3 meV	781.0 meV

# Effect of thermal randomness

