

Zi-yang Li, Yi-ming Zhang, Dong-sheng Li, Peng-fei Zhang, Xi-cheng Lu, 2016.  
VirtMan: design and implementation of a fast booting system for homogeneous  
virtual machines in iVCE. *Frontiers of Information Technology & Electronic  
Engineering*, 17(2):110-121. <http://dx.doi.org/10.1631/FITEE.1500216>

# VirtMan: design and implementation of a fast booting system for homogeneous virtual machines in iVCE

**Key words:** Virtual machine, Fast booting, Homogeneity,  
Internet-based virtual computing environment (iVCE)

Contact: Yi-ming Zhang

E-mail: [ymzhang@nudt.edu.cn](mailto:ymzhang@nudt.edu.cn)

 ORCID: <http://orcid.org/0000-0001-6450-8485>

# Motivation/Main ideas

## ○ Motivation

- ✓ Many cloud applications (e.g., animation rendering, material analysis, and fluid simulation) require hundreds or even thousands of VMs to run concurrently for performance purpose.

## ○ Main ideas

- ✓ Cache group
- ✓ Cache-based snapshot
- ✓ Hierarchical attaching

# Main ideas (1) - Cached group

- A group of cached volumes supports dynamically adding and removing

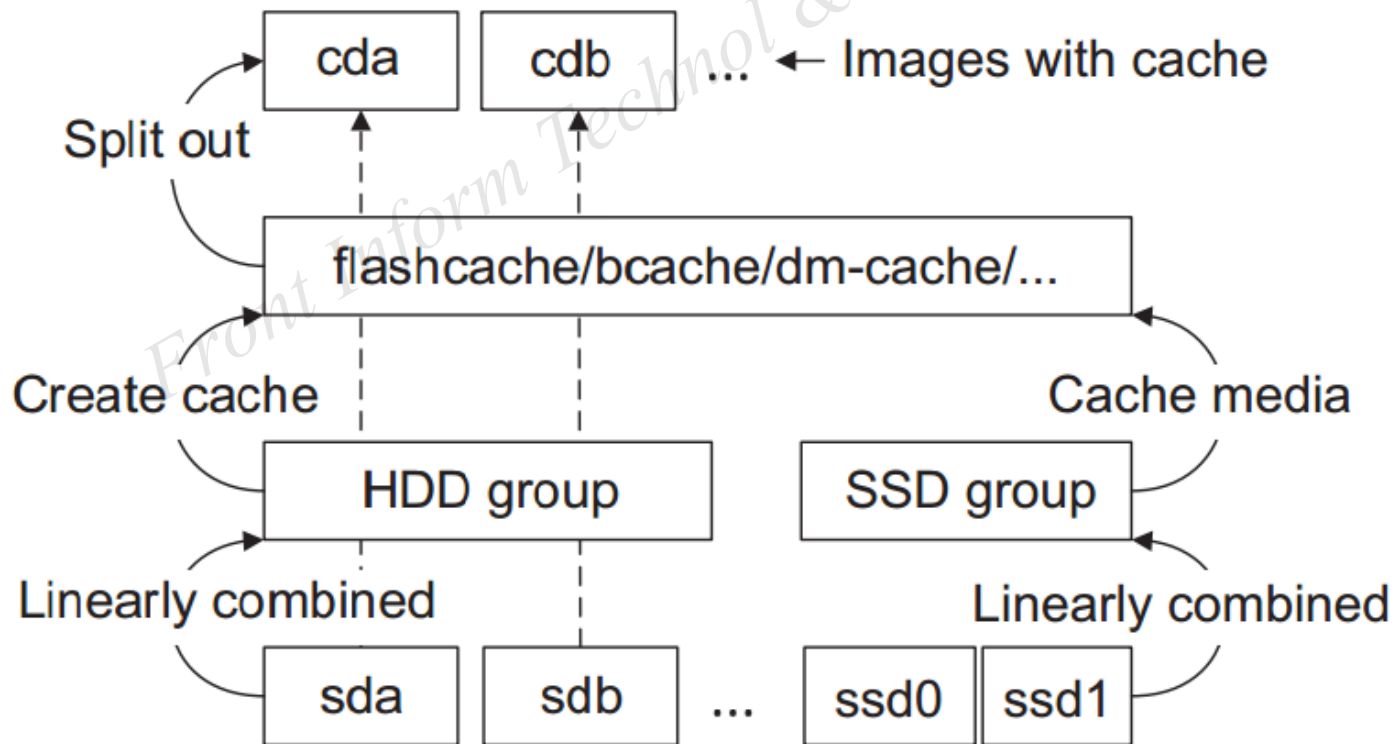

# Main ideas (2) - Cache-based snapshot

- **VirtMan builds the snapshot to boot up VMs from the cached image**

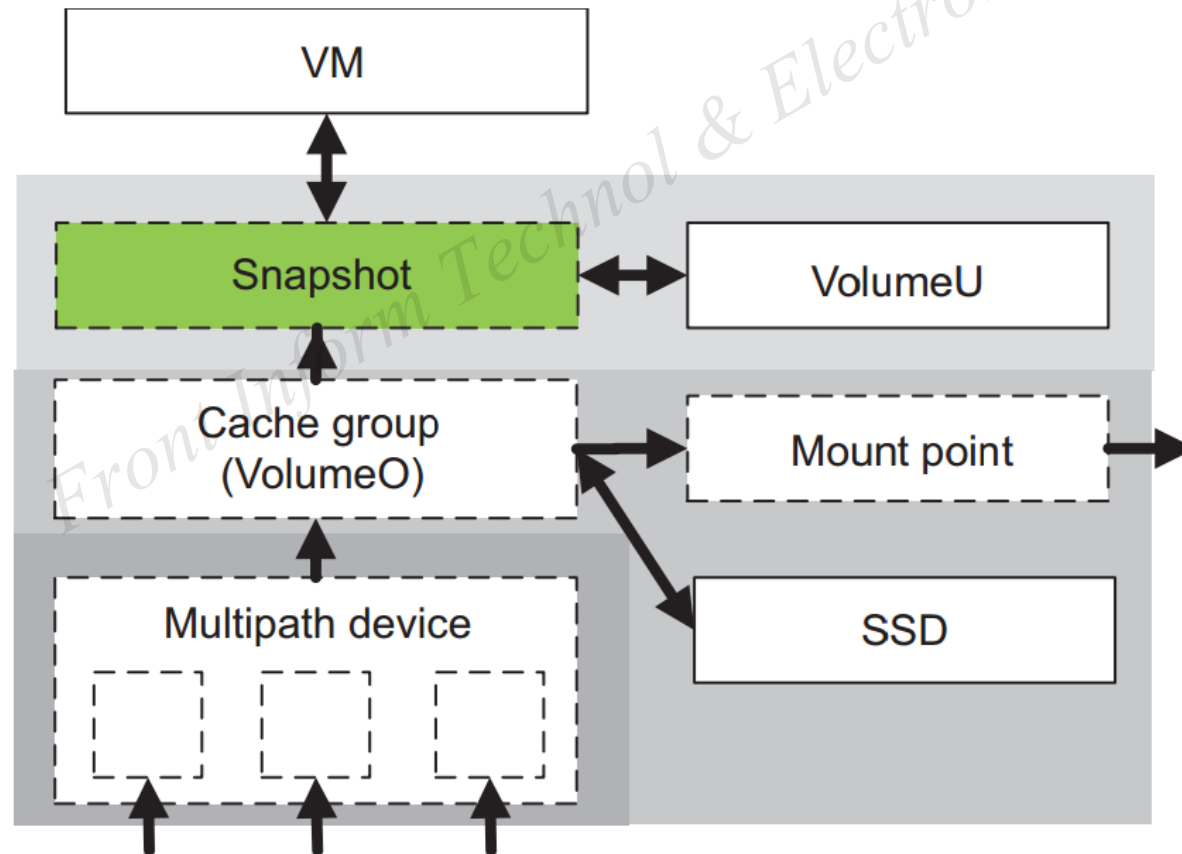

# Main ideas (3) - Hierarchical attaching

- **VirtMan uses hierarchical attaching to avoid the possibility of bottleneck**

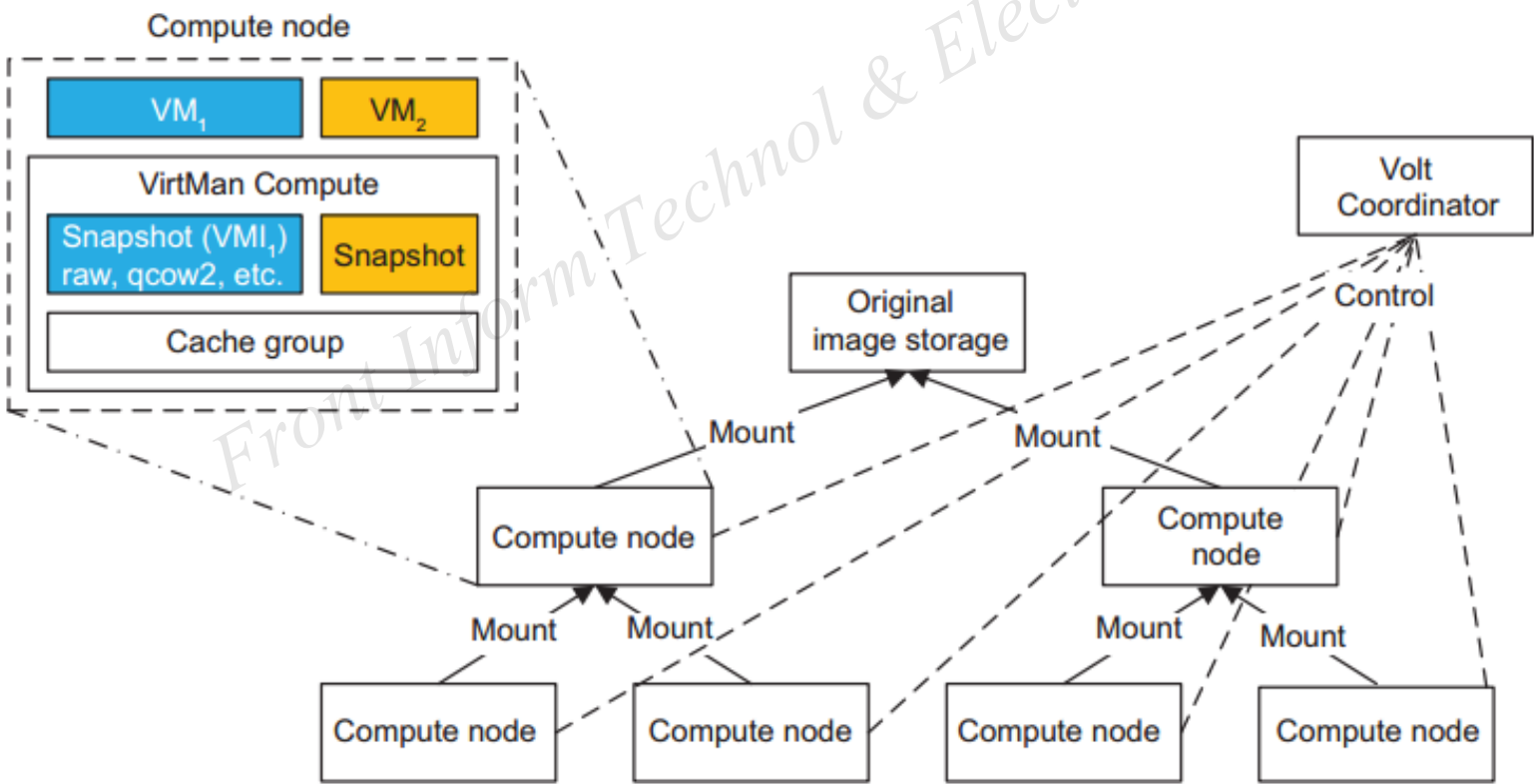

# Coordinator (Master)

- Topology maintenance
  - maintain the position information for all nodes
- Control image streaming
  - Dynamically construct the P2P relay tree
  - Notify all nodes to mount to their parents

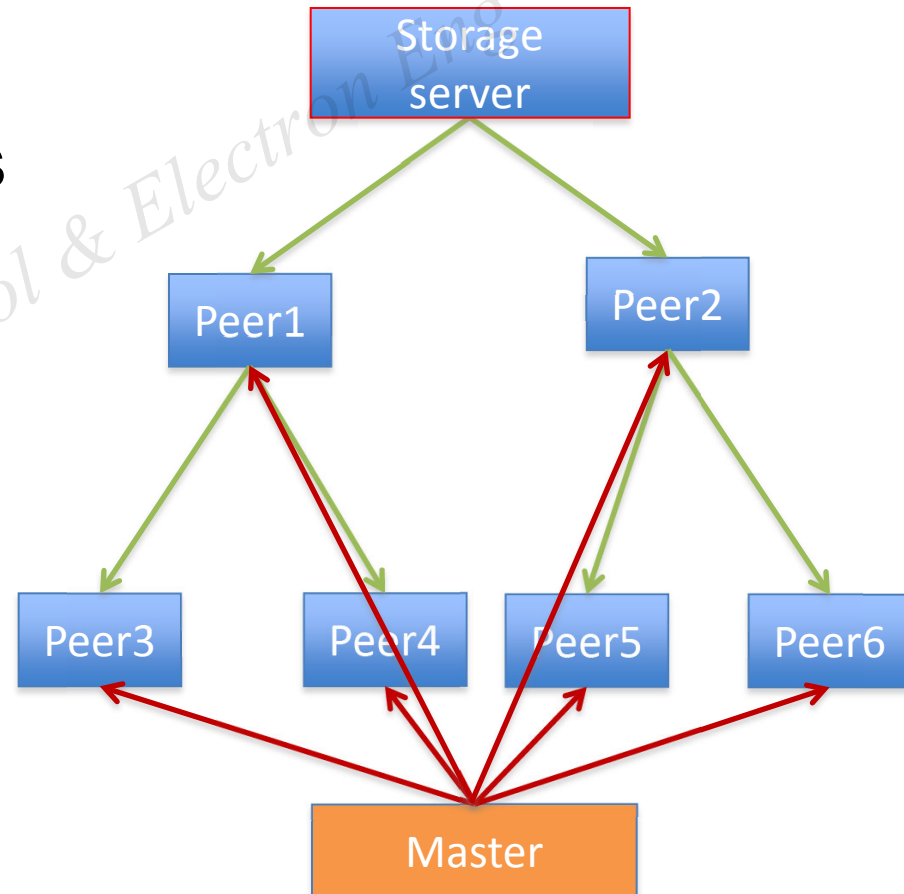

- Fast failure detection based on heartbeats
  - So that the relay tree can be timely repaired when a node fails
- Configure multiple parents in the relay tree
  - To achieve fault tolerance and load balance

Front Inform Technol & Electron Eng

# VirtMan architecture

- VirtMan open source implementation  
<https://github.com/vmthunder>

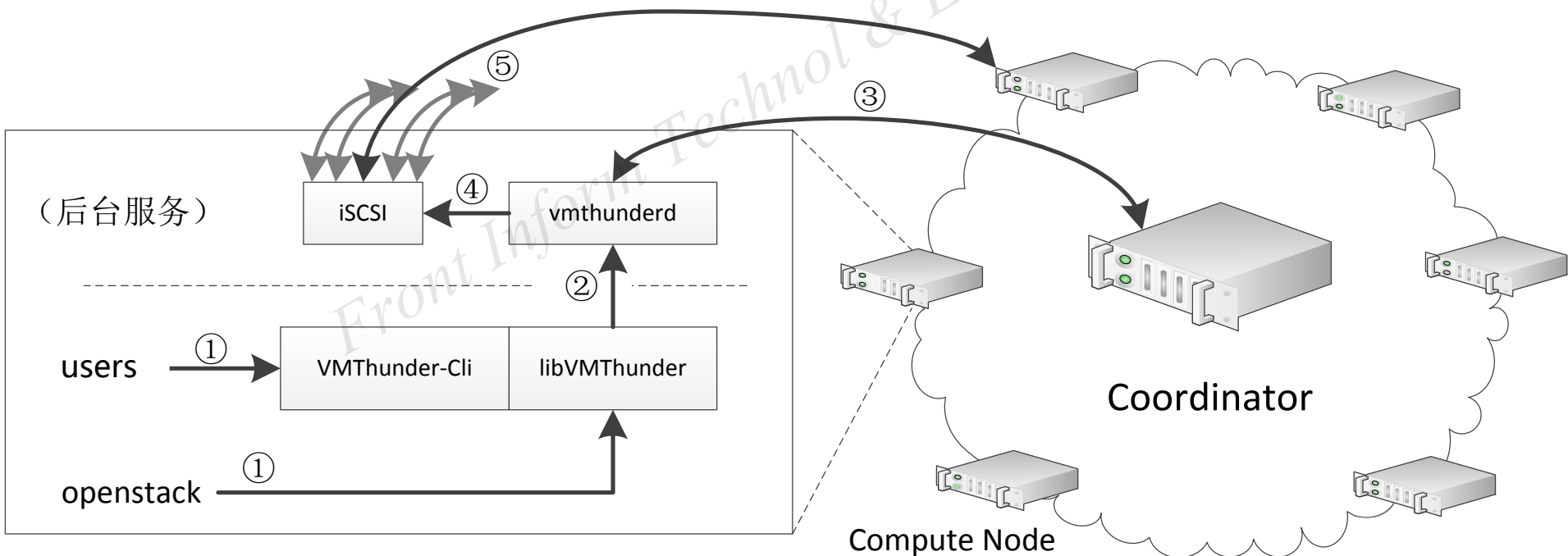

# Results (1)

- Boot up 1000 VMs
  - (Blue) VirtMan can boot up 1000 VMs in <120 s.

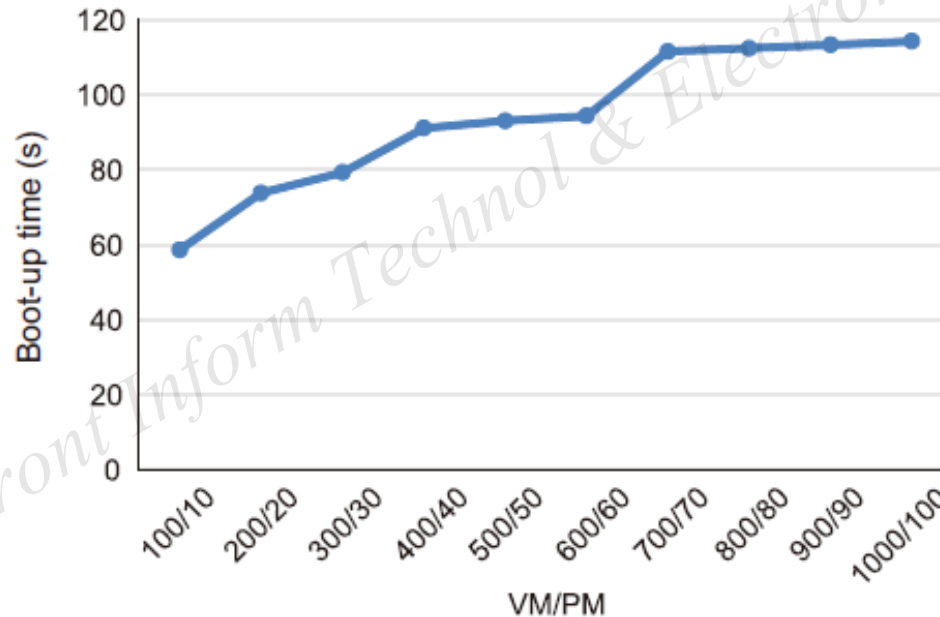

**Fig. 5 Standalone VirtMan boot-up time (VM: number of virtual machines; PM: number of physical machines)**

# Results (2)

- Accelerate OpenStack

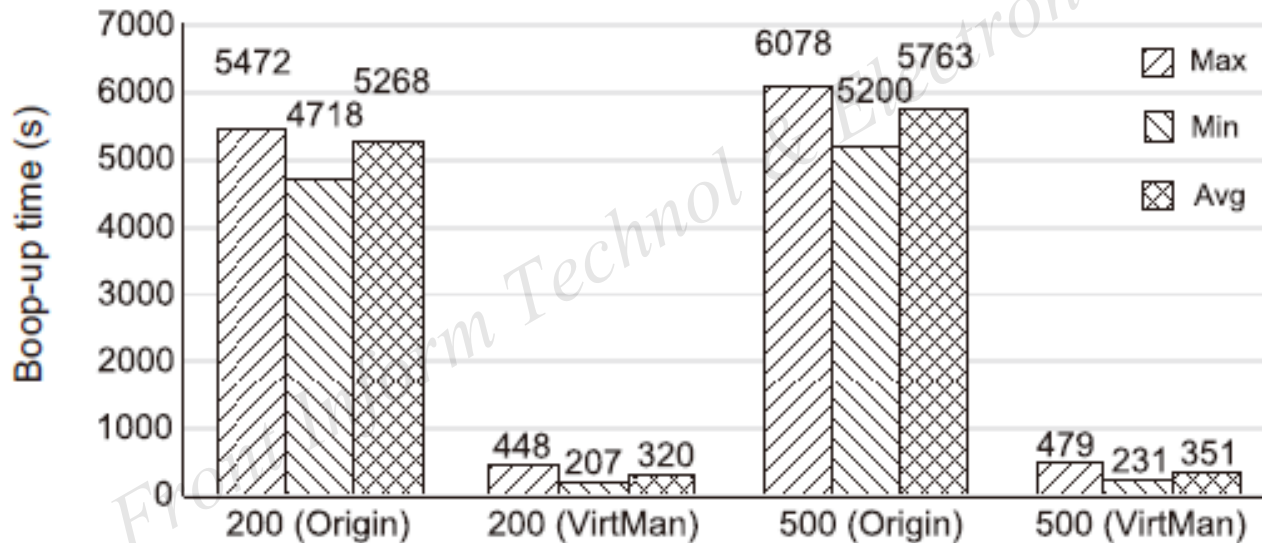

**Fig. 7 OpenStack-based VirtMan boot-up time. ‘Origin’ represents the original OpenStack and ‘VirtMan’ represents the VirtMan-enabled OpenStack**

# Conclusions

- We design and implement VirtMan, a fast booting system for a large number of homogeneous VMs in iVCE.
- With the techniques, such as cache group, cache group based snapshot, and hierarchical attaching, VirtMan can boot a thousand of homogeneous VMs in only 2 min.