

Gang WANG, Georgios B. GIANNAKIS, Jie CHEN, Jian SUN, 2019. Distribution system state estimation: an overview of recent developments. *Frontiers of Information Technology & Electronic Engineering*, 20(1):4-17.

<https://doi.org/10.1631/FITEE.1800590>

Distribution system state estimation: an overview of recent developments

Key words: State estimation; Cramér-Rao bound; Feasible point pursuit; Semidefinite relaxation; Proximal linear algorithm; Composite optimization; Cyber attack; Bad data detection

Corresponding author: Jian SUN
E-mail: sunjian@bit.edu.cn

Main Ideas

1. In this study, we provide a contemporary overview of power system state estimation (PSSE), linking the relevant physics to the signal processing and (nonconvex) optimization methods and algorithms.
2. Our main goal is to describe some of the recent advances in this area, identify current challenges, and suggest possible directions for future research.

Methods

1. Weighted least-squares estimation:

- (1) Gauss-Newton method;
- (2) Semidefinite relaxation;
- (3) Feasible point pursuit;
- (4) Cramér-Rao lower bound.

2. Weighted least-absolute-value estimation:

- (1) Iteratively reweighted least-squares;
- (2) Linear programming;
- (3) Deterministic and stochastic prox-linear algorithms.

Motivation

High-penetration of uncertain renewables, unpredictable participation of customers, and purposeful manipulation of smart meter readings are shown in the envisioned smart grid.



Distributed generation
micro-grids



Renewables

Advanced metering



Demand response

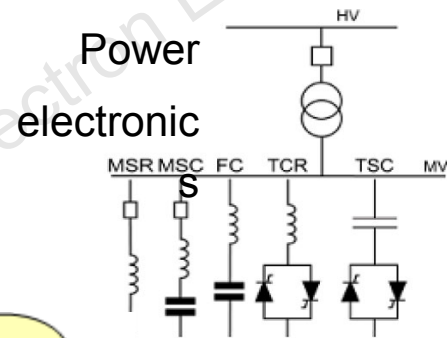
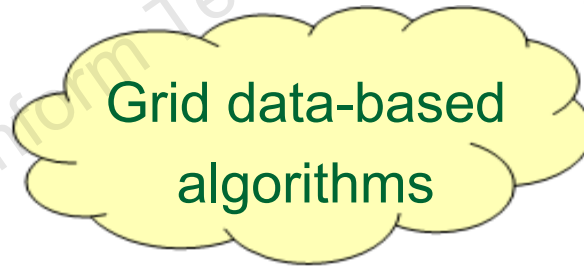

Electric vehicles



Communication
networks

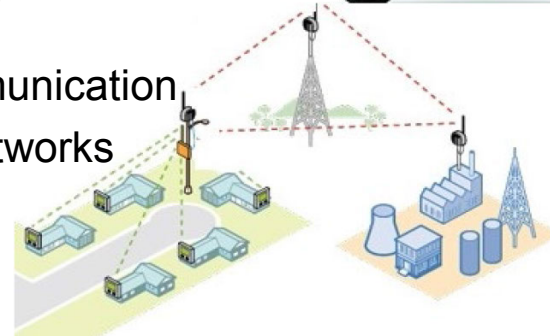

Results

Accurate, fast, and robust state estimation approaches:

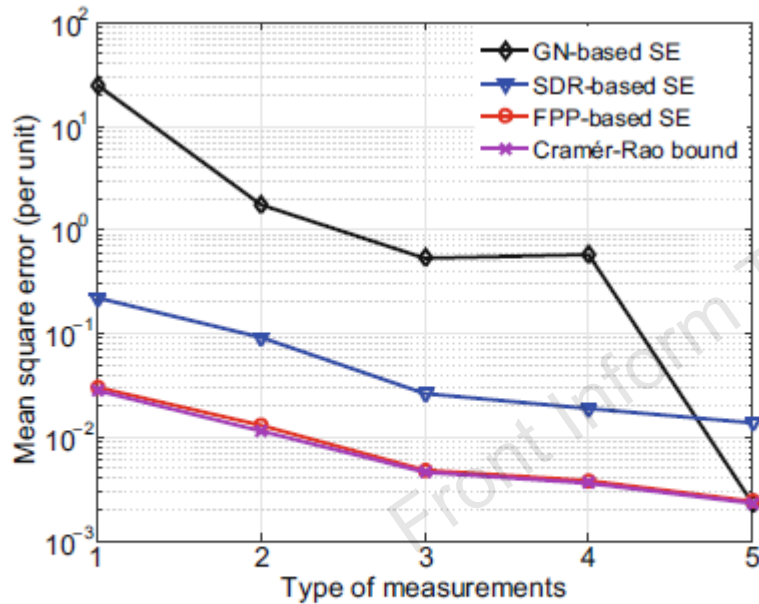

Fig. 1 MSE and Cramér-Rao bound versus the type of measurements used for the IEEE 14-bus system

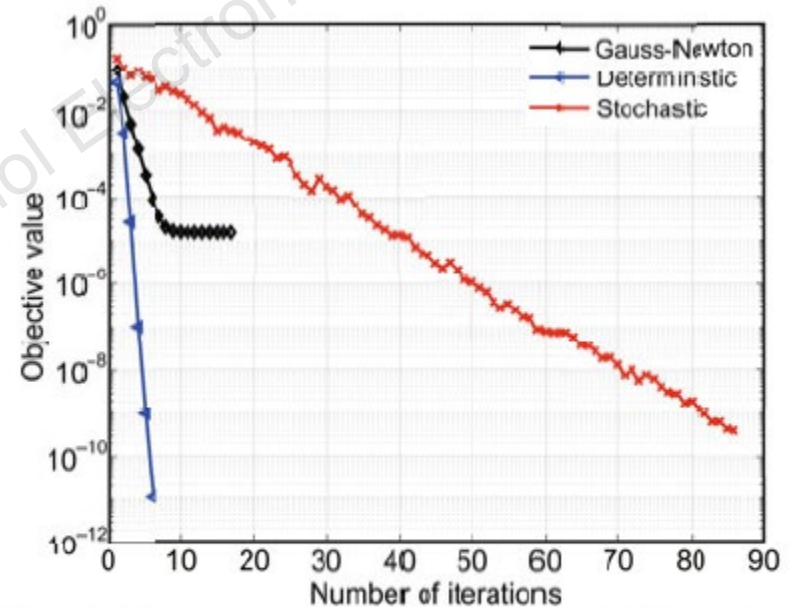

Fig. 3 Convergence performance of Gauss-Newton, deterministic, and stochastic prox-linear algorithms for the IEEE 14-bus system

Conclusions

1. Nonconvex approaches for power system state estimation were reviewed.
2. Cramér-Rao lower bound to benchmark performance was reviewed.
3. Composite optimization via proximal linear algorithms was reviewed.
4. Deep learning for data-drive power system state estimation was reviewed.