

Dewen SENG, Fanshun LV, Ziyi LIANG, Xiaoying SHI, Qiming FANG, 2021.  
Forecasting traffic flows in irregular regions with multi-graph convolutional  
network and gated recurrent unit. *Frontiers of Information Technology &  
Electronic Engineering*, 22(9):1179-1193. <https://doi.org/10.1631/FITEE.2000243>

# Forecasting traffic flows in irregular regions with multi-graph convolutional network and gated recurrent unit

**Key words:** Traffic flow prediction; Multi-graph convolutional network;  
Gated recurrent unit; Irregular regions

Corresponding author: Xiaoying SHI

E-mail: [shixiaoying@hdu.edu.cn](mailto:shixiaoying@hdu.edu.cn)

 ORCID: <https://orcid.org/0000-0003-0452-2503>

# Motivation

1. Traditional time-series forecasting methods, such as autoregressive integrated moving average (ARIMA), the time-varying Poisson model, and the vector autoregressive model, consider only temporal dependence and have relatively low prediction accuracy.
2. Deep learning based models, such as the convolutional neural network and residual neural network, could predict only grid-level flows, and fail to predict the demands of irregular regions.
3. Multiple complex relationships among regions help model various spatial dependencies among irregular regions.

# Main idea

1. We view traffic flows in a city from the graph perspective, and construct three heterogeneous inter-region graphs to encode various spatial dependencies.
2. We design a deep learning based prediction model (MGCN-GRU), which combines the multi-graph convolutional network and GRU, to forecast traffic flows in irregular regions.
3. The proposed model is assessed by three real-world traffic datasets.

# Method

1. Various spatial dependencies among irregular regions are encoded by three heterogeneous inter-region graphs.
2. A multi-graph convolutional network is proposed to fuse the complex non-Euclidean correlations among irregular regions, and a GRU is built to capture the dynamic temporal patterns.

# Method

MGCN-GRU model:

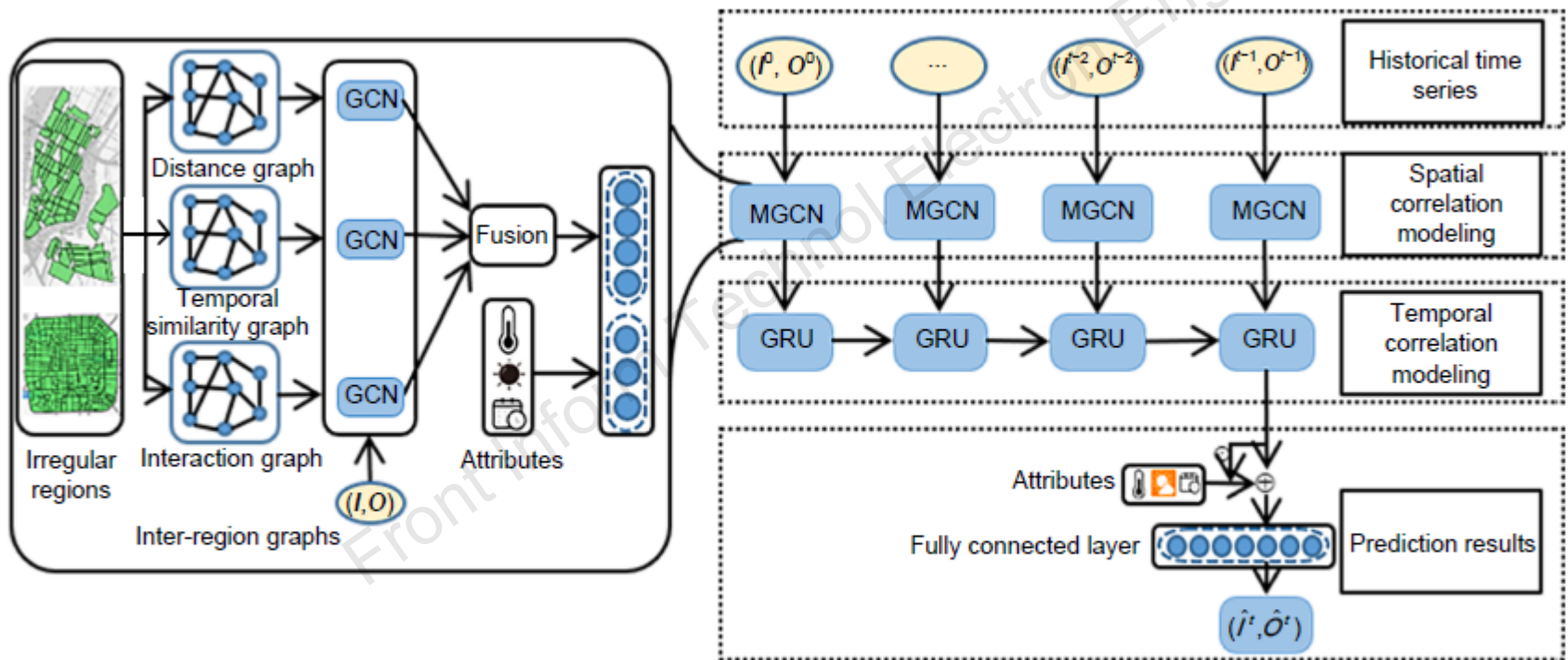

Fig. 1 Architecture of the proposed multi-graph convolutional network and gated recurrent unit (MGCN-GRU) model

# Major results

Test results of different loss functions:

Table 1 Prediction accuracy comparison between different loss functions

Loss function	RMSE			MAE		
	PBS dataset	Taxi dataset	DBS dataset	PBS dataset	Taxi dataset	DBS dataset
Absolute-error function	3.2506	45.4916	11.8972	1.8023	24.5878	3.4953
Squared-error function	3.2541	45.0784	11.1388	1.8037	24.3731	3.2802
Smooth L1 function	<b>3.1846</b>	<b>44.7117</b>	<b>10.6384</b>	<b>1.7818</b>	<b>24.1932</b>	<b>3.0705</b>

RMSE: root mean square error; MAE: mean absolute error. Best results are in bold

# Major results (Cont'd)

Test results of our model and related methods:

Table 2 Prediction accuracy comparison between different models

Model	RMSE			MAE		
	PBS dataset	Taxi dataset	DBS dataset	PBS dataset	Taxi dataset	DBS dataset
HA	7.7134	71.7902	19.9643	3.8163	34.4045	5.3395
ARIMA	5.2191	88.2771	23.7872	2.7086	45.3036	6.8241
MGCN	4.9874	72.6974	17.8231	2.6484	36.5174	6.2653
LSTM	3.4460	50.8887	13.5471	1.9809	28.7526	5.3938
GRU	3.4371	50.8379	13.4207	1.9629	28.3321	5.4848
MGCN-GRU	<b>3.1846</b>	<b>44.7117</b>	<b>10.6384</b>	<b>1.7818</b>	<b>24.1932</b>	<b>3.0705</b>

Best results are in bold

# Conclusions

1. A multi-graph convolutional network has been proposed to model the heterogeneous spatial relationships among irregular regions.
2. A novel deep learning based prediction model (MGCN-GRU), which combines the multi-graph convolutional network and GRU, is proposed to forecast traffic flows in irregular regions.
3. Compared with various previous methods, the MGCN-GRU model can obtain the best prediction results on three real-world traffic datasets.

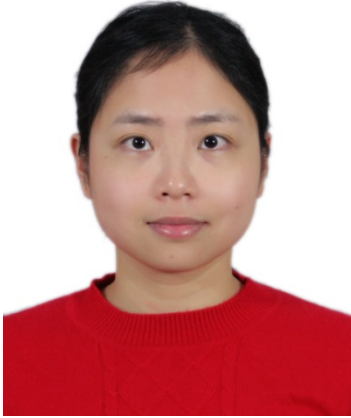

Xiaoying SHI, corresponding author of this paper, received her PhD degree in control theory and control engineering from Zhejiang University of Technology in 2014. She is currently a lecturer at School of Computer Science and Technology, Hangzhou Dianzi University, China. Her research interests include visual analytics, data mining, and urban transportation.



Dewen SENG received his PhD degree from University of Science and Technology Beijing in 2005. He is currently an associate professor with School of Computer Science and Technology, Hangzhou Dianzi University. His research interests include intelligent transportation system, mobile internet, and data mining.