

Yang GAO, Fan ZHANG, Yingying QIAO, JiaWei ZANG, Lei LI, Xiaobang SHANG, 2021. A microstrip filter direct-coupled amplifier based on active coupling matrix synthesis. *Frontiers of Information Technology & Electronic Engineering*, 22(9):1260-1269. <https://doi.org/10.1631/FITEE.2000292>

A microstrip filter direct-coupled amplifier based on active coupling matrix synthesis

Key words: Amplifier; Filter–amplifier integration; Microstrip; Coupling matrix

Corresponding author: Lei LI

E-mail: lilei@zzu.edu.cn

 ORCID: <https://orcid.org/0000-0001-7394-4094>

Motivation

1. Electromagnetic wave loss is a significant concern in high frequency devices, especially in millimeter or terahertz frequencies.
2. Integration of the multifunctional devices can effectively reduce loss, and increase power, efficiency, gain, or other key performances.
3. Coupling matrix synthesis shows great potential in the design of integrated passive/active microwave devices.

Main idea

1. Filters can be directly coupled to the active device, by eliminating the need for separate matching networks. This integration of the filter–amplifier leads to a reduced loss and a more compact architecture of the devices.
2. Novel coupling matrix can be synthesized and used to calculate the filter–amplifier responses (i.e., return loss and gain) and the initial dimensions of the integrated device.

Method

1. A matrix scaling process is developed to achieve incorporation of the transistor elements, which generalize the classic passive $N+2$ to the active $N+3$ coupling matrices.
2. A filter direct-coupled amplifier structure is proposed, and the initial values of the physical construction can be guided by the synthesized coupling matrix.

Method

Conventional amplifier and the filter direct-coupled amplifier

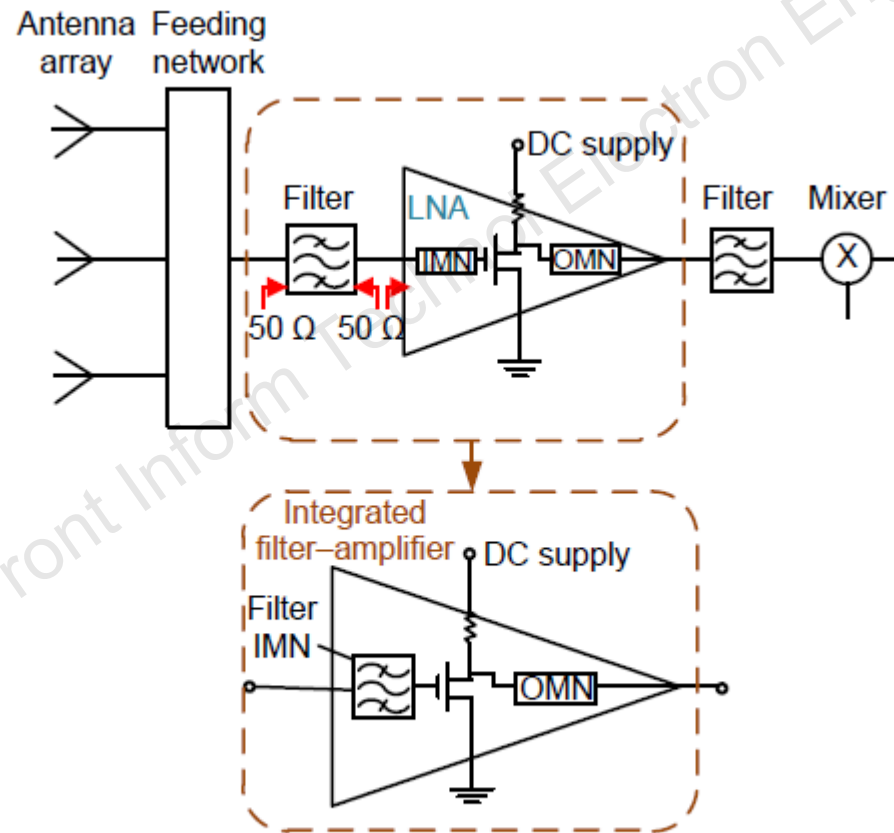

Fig. 1 Conventional amplifier employed in a receiver system and the filter direct-coupled amplifier

Method

Circuit topology and matrix synthesis process

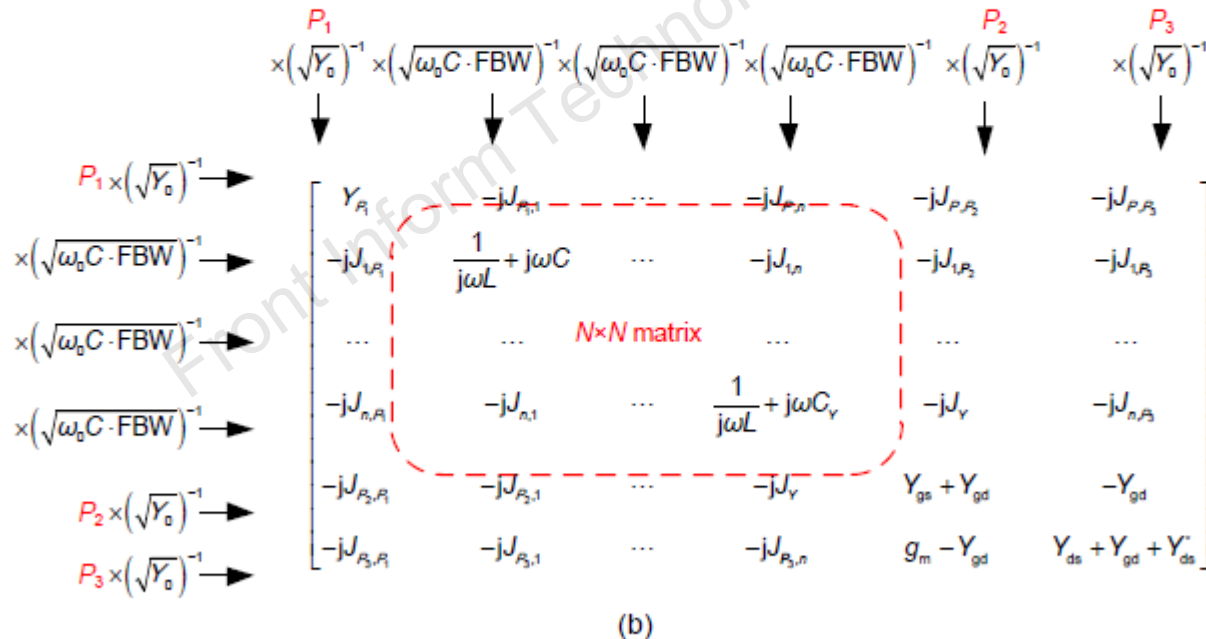
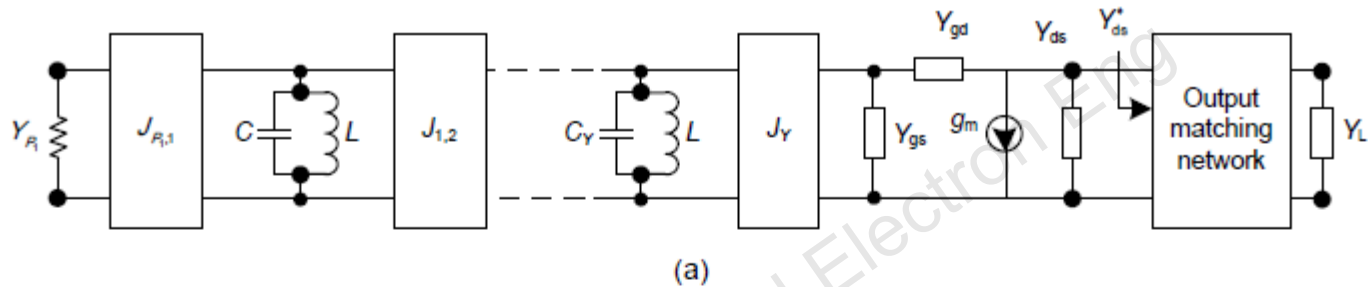

Fig. 2 Simplified lumped circuit of the filter direct-coupled amplifier (a) and matrix $[Y]$ of the lumped circuit and matrix scaling operation from $[Y]$ to $[\bar{Y}]$ (b)

Method

Manufactured X-band microstrip filter direct-coupled amplifier

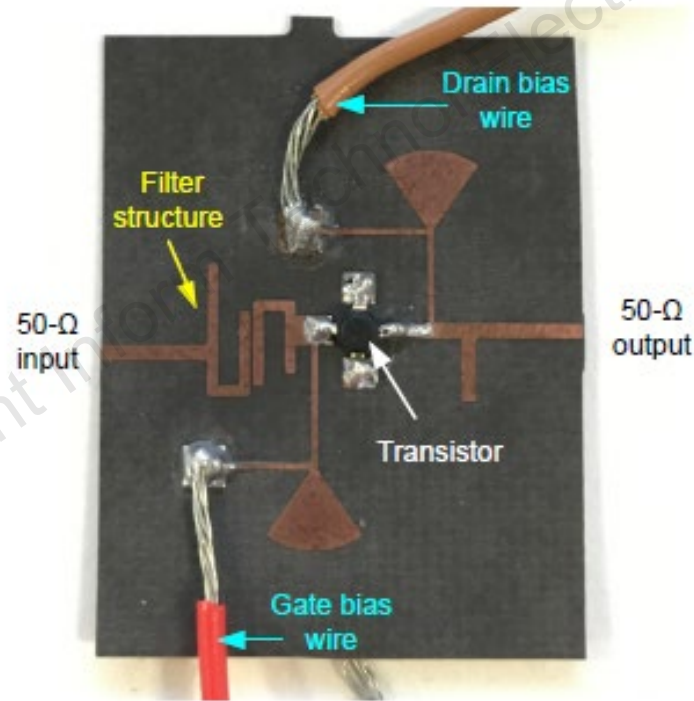

Fig. 11 Photograph of the X-band microstrip filter amplifier

Major results

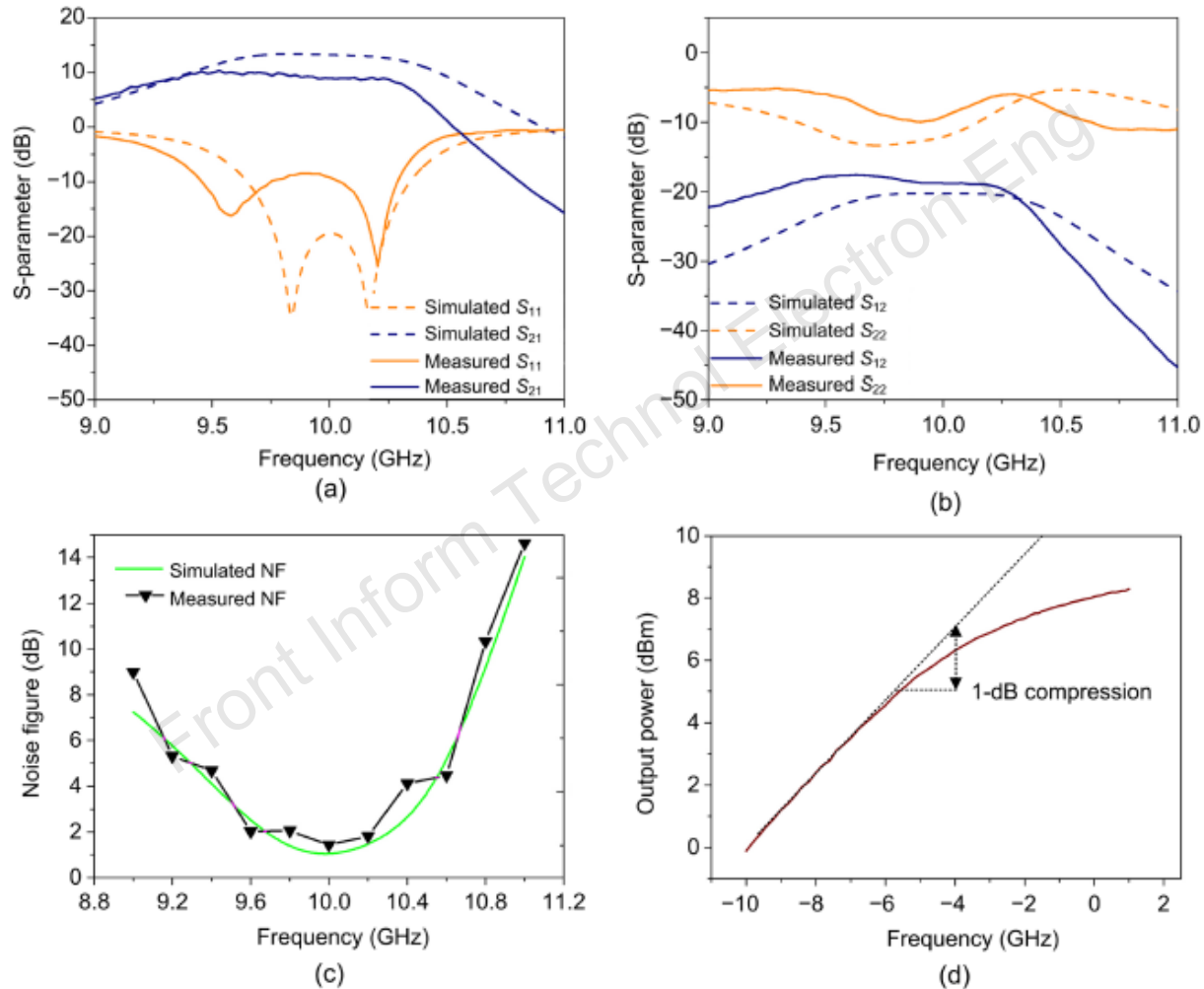

Fig. 12 Measurement and simulation results: (a) S_{11} and S_{21} ; (b) S_{22} and S_{12} ; (c) noise figure; (d) P1-dB measurement

Conclusions

1. An active coupling matrix representing a direct filter coupled amplifier has been synthesized. Matrix manipulation and a scaling process have been performed to construct this novel active coupling matrix.
2. The integration technique using coupling matrix synthesis can be adopted for other types of devices with complex ports, e.g., mixers, oscillators, and frequency multipliers.



Yang GAO received his BS degree in electronic engineering from Beijing Institute of Technology, Beijing, China, in 2014, and his PhD degree in radio physics from University of Birmingham, Birmingham, UK, in 2018. He joined Zhengzhou University, Zhengzhou, China, as a lecturer in 2019. He is also an Honorary Research Fellow with the Emerging Device Technology Group, University of Birmingham. Yang's current research interests include microwave integrated circuits (IC), passive/active devices, and microwave sensing and imaging systems.



Prof. Lei LI received his BS degree in electronic engineering from Zhengzhou University, Zhengzhou, China, in 2004, and his PhD degree in electronic engineering from the Institute of Acoustics, Chinese Academy of Sciences, in 2009. He is currently an Associate Professor with the School of Physics and Microelectronics, Zhengzhou University. His current research interests include array signal processing, optical gas sensing, and photoacoustic spectroscopy.