

Jin XUE, Renhai CHEN, Tianyu WANG, Zili SHAO, 2023. SoftSSD: enabling rapid flash firmware prototyping for solid-state drives. *Frontiers of Information Technology & Electronic Engineering*, 24(5):659-674. <https://doi.org/10.1631/FITEE.2200456>

# SoftSSD: enabling rapid flash firmware prototyping for solid-state drives

**Key words:** Solid-state drives; Storage system; Software hardware co-design

Corresponding author: Renhai CHEN

E-mail: [renhai.chen@tju.edu.cn](mailto:renhai.chen@tju.edu.cn)

 ORCID: <https://orcid.org/0000-0002-0233-5838>

# Motivation

1. The research of flash firmware has been mostly based on simulations due to the lack of a **realistic and extensible solid-state drive (SSD) development platform**.
2. **Hardware-based SSD development platforms** are not user-friendly to firmware developers who are more familiar with software design.
3. **A novel software-oriented and flexible SSD development platform** is proposed and implemented for rapid flash firmware prototyping.

# Design

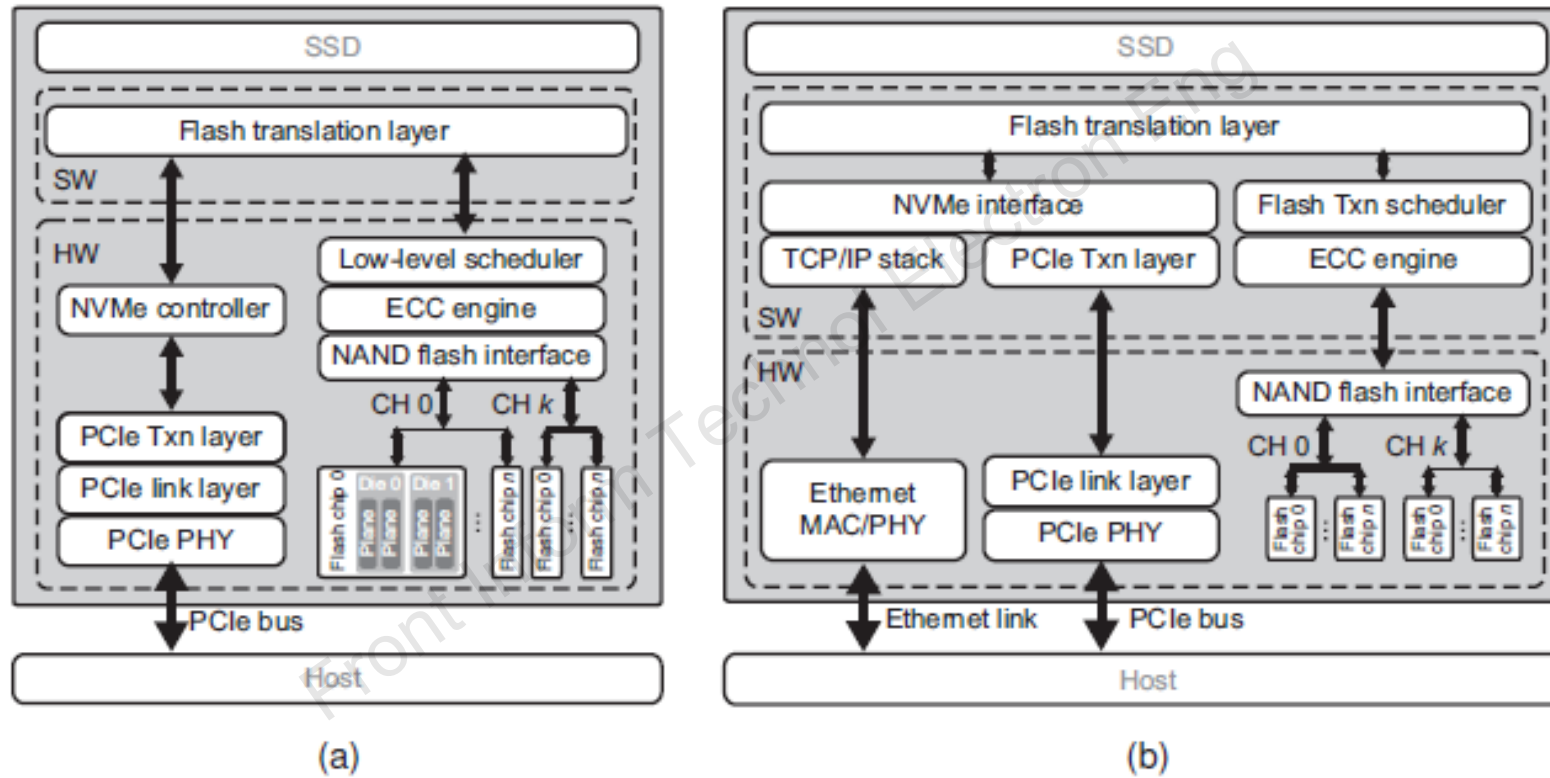

Fig. 1 Comparison of existing hardware-oriented platforms (a) and SoftSSD (b)

# Design (Cont'd)

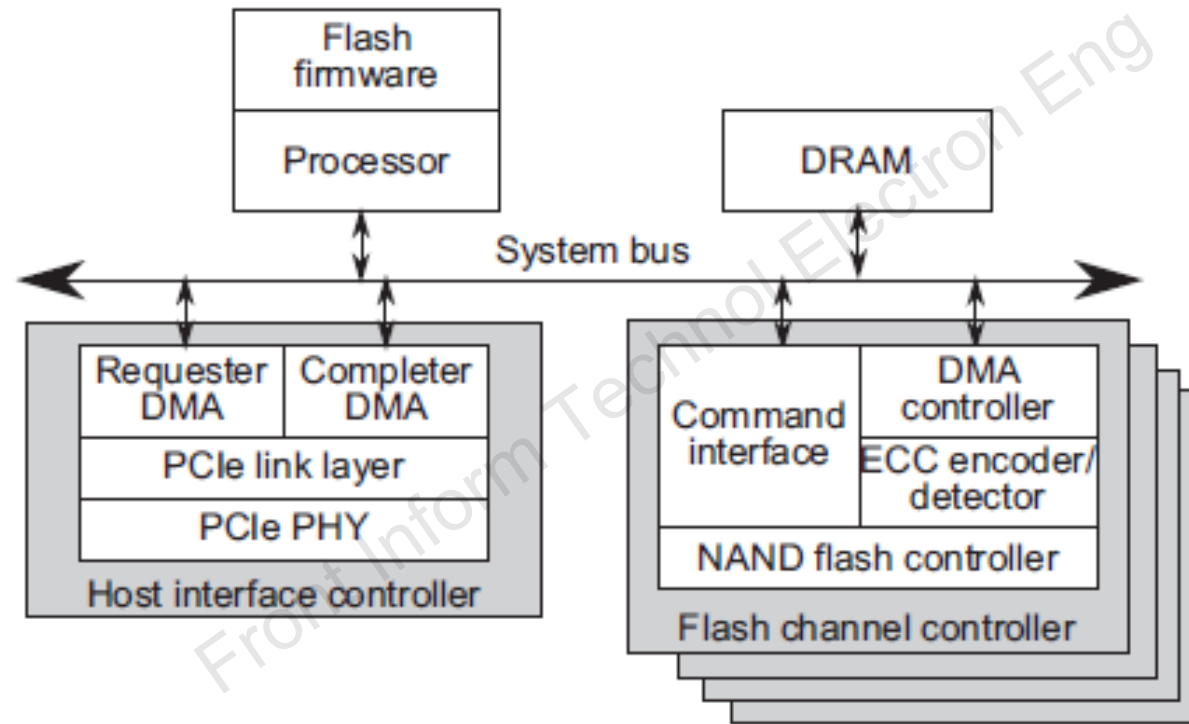

Fig. 2 Overall architecture of the SoftSSD hardware components

# Design (Cont'd)

An easy-to-use **application programming interface** for flash firmware to interact with the host is proposed.

```
void pcie_mem_read_callback(int bar_nr,
    unsigned long addr, u16 requester_id, u8
    tag, size_t len);
void pcie_mem_write_callback(int bar_nr,
    unsigned long addr, const u8* buf,
    size_t len);
int pcie_send_completion(unsigned long addr,
    u16 requester_id, u8 tag, const u8*
    buffer, size_t count);
int pcie_dma_read(unsigned long host_addr,
    u8* buffer, size_t count);
int pcie_dma_write(unsigned long host_addr,
    const u8* buffer, size_t count);
void pcie_send_msi(u16 vector).
```

# Design (Cont'd)

Requests are scheduled with a **coroutine framework** to overlap computation and input/output operations.

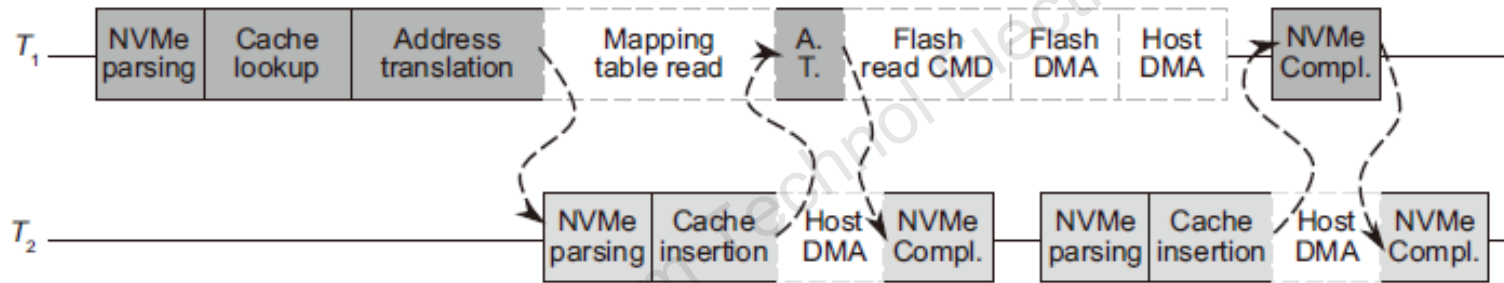
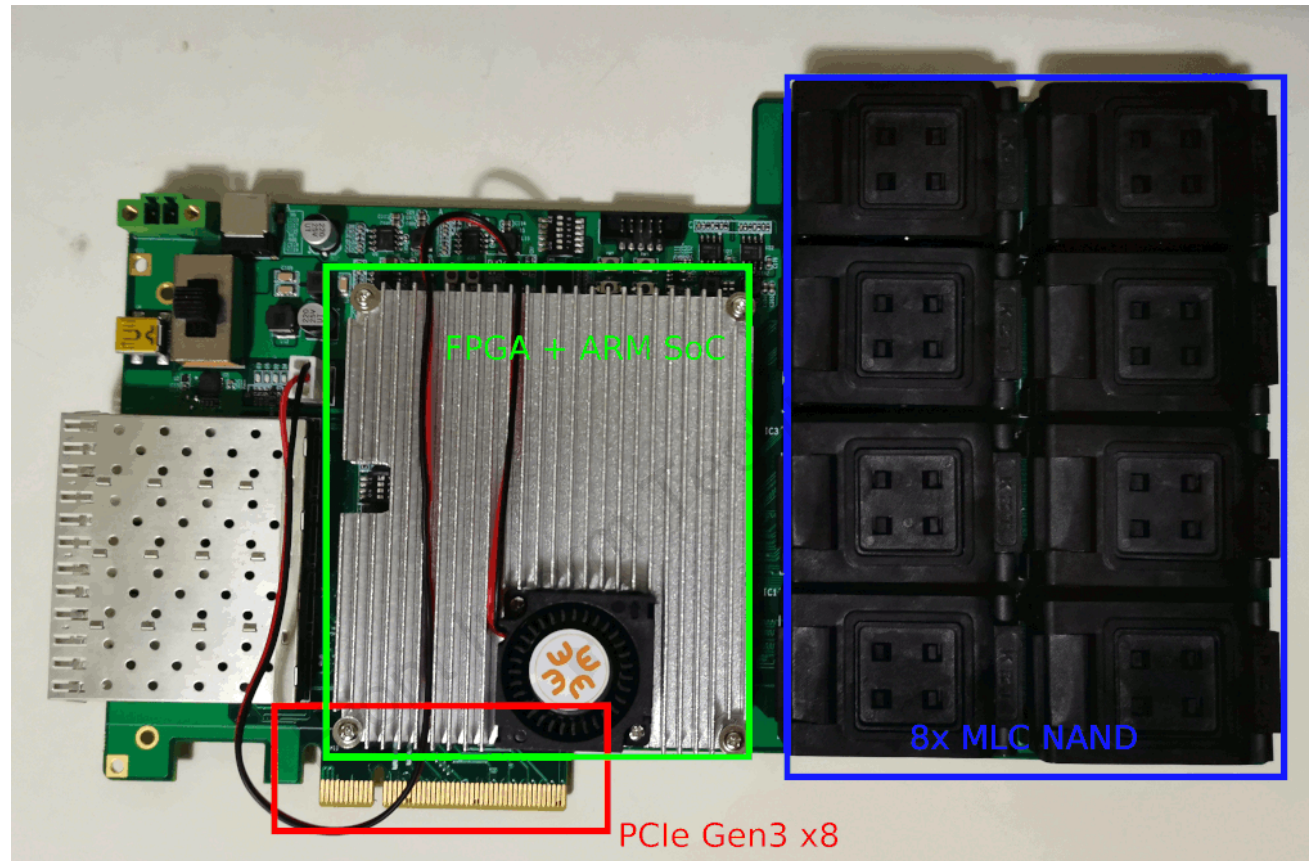

Fig. 5 An example of request processing under the proposed programming model with two threads

# Development board



**Fig. 7** Hardware development board of SoftSSD prototype

# Conclusions

1. We proposed SoftSSD, which enables **rapid prototyping** of flash firmware on a real hardware platform.
2. We implemented the majority of components in **pure software** so that SoftSSD can provide better observability of the internal states in the SSD.
3. We conducted experiments with **real application workloads** to demonstrate the performance of SoftSSD as a standard storage device.