

Mianfeng HUANG, Juhua LIU, 2023. An array of two periodic leaky-wave antennas with sum and difference beam scanning for application in target detection and tracking. *Frontiers of Information Technology & Electronic Engineering*, 24(4):567-581. <http://doi.org/10.1631/FITEE.2200473>

An array of two periodic leaky-wave antennas with sum and difference beam scanning for application in target detection and tracking

Key words: Antenna; Leaky-wave antenna (LWA); Substrate-integrated waveguide (SIW); Sum and difference beam; Target detection and tracking

Corresponding author: Juhua Liu
E-mail: liujh33@mail.sysu.edu.cn

 ORCID: <https://orcid.org/0000-0003-4725-6241>

Motivation

- In a single beam scanning radar, the target detection accuracy is limited by the beam width and it is inconvenient to achieve target tracking. Sum and difference beam scanning is preferred for high-accuracy radar.
- For target detection and tracking applications, a mechanical scanning antenna is bulky and a phased array usually requires complex feed networks. A simpler alternative is to use leaky-wave antenna (LWA), which has beam scanning with frequency.
- LWA with sum and difference beam scanning capability offers a potential and low-cost solution for achieving high-accuracy target detection and tracking. Therefore, it possesses significant application value in radar systems.

Main idea

- Two periodic LWAs of different periods generate two main beams of slightly different radiation angles, which can be merged to a sum beam or a difference beam, depending on the in-phase or out-phase of the excitations.

Method

- A periodic LWA can generate a beam through the radiation of its $n=-1$ space harmonic
- Two LWAs with slightly different periods can generate two beams with slightly different angles

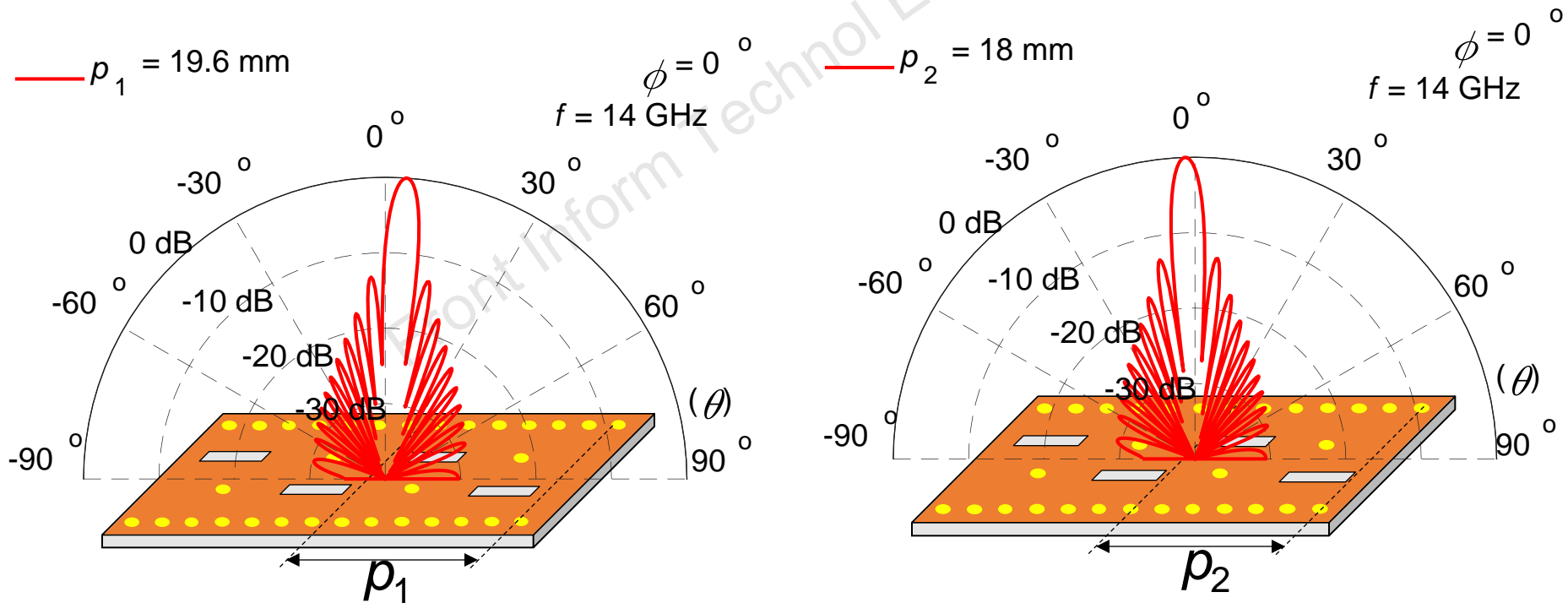

Method (Cont'd)

- According to the principle of complex far-field superposition, the two complex far-field patterns are merged to obtain the sum and difference beam.

$$\begin{aligned}
 F_{\Sigma/\Delta}(\theta) &= \int_0^L (M_{s1} + M_{s2}) e^{jk_0 x \sin \theta} dx \\
 &= A_1 \cdot \left(\frac{1 - e^{jk_0 L \sin \theta} e^{-\alpha_1 L} e^{-j\beta_{-1,1} L}}{\alpha_1 + j\beta_{-1,1} - jk_0 \sin \theta} \right. \\
 &\quad \left. + \rho \cdot \frac{1 - e^{jk_0 L \sin \theta} e^{-\alpha_2 L} e^{-j\beta_{-1,2} L}}{\alpha_2 + j\beta_{-1,2} - jk_0 \sin \theta} \right)
 \end{aligned}$$

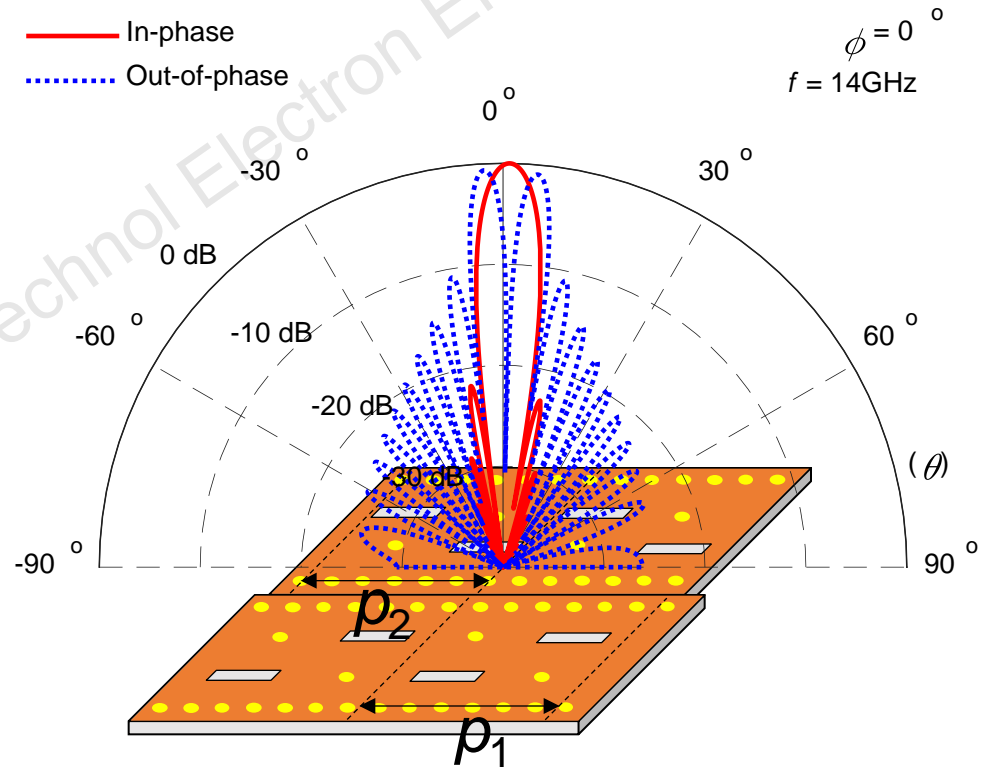

Feeding structure

- Design a wideband 180° hybrid whose operating band is consistent with the array of two periodic LWAs

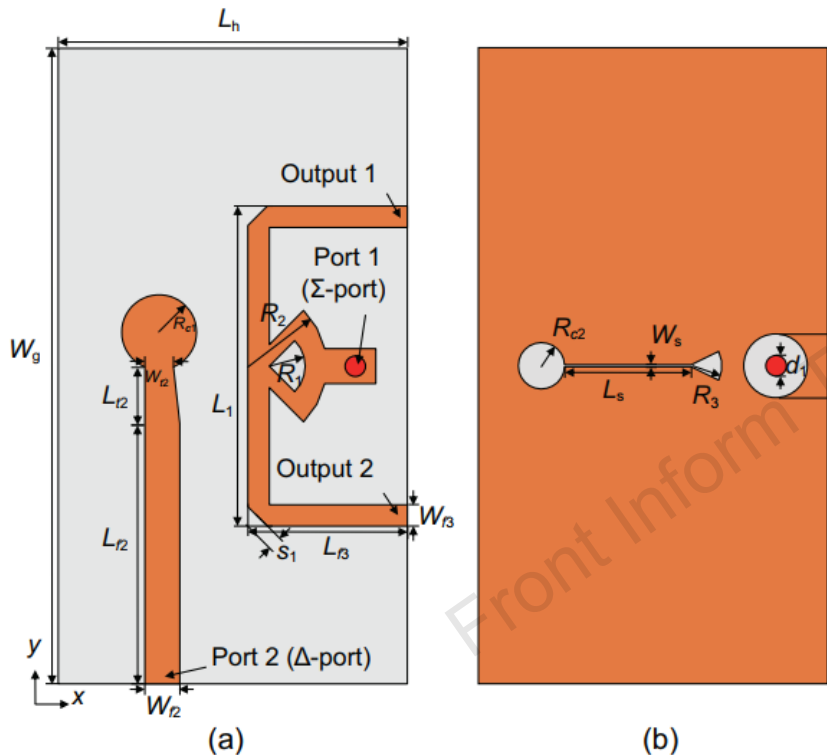

Fig. 2 Geometry of the wideband 180° hybrid: (a) top view; (b) bottom view

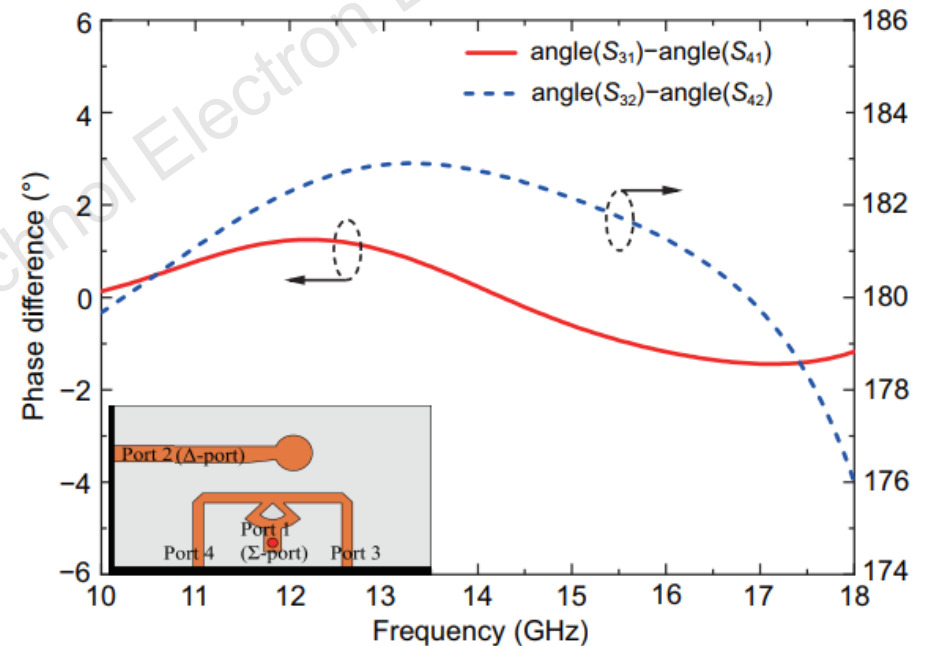

Fig. 7 Phase difference between the two output ports (ports 3 and 4) of the wideband 180° hybrid

Measurement

The proposed antenna

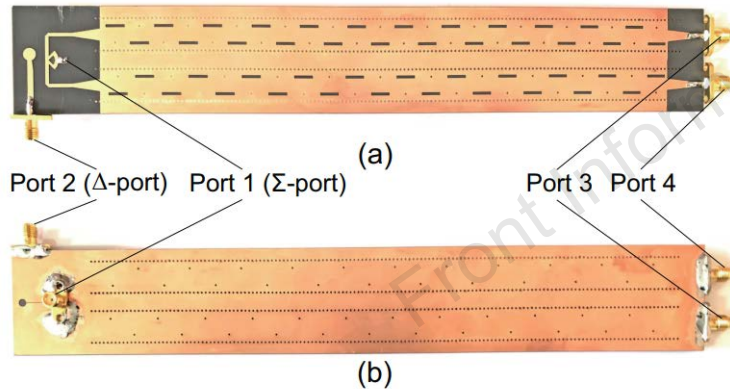

Fig. 10 Array of two periodic LWAs with different periods integrated with the 180° hybrid: (a) top view; (b) bottom view (LWA: leaky-wave antenna)

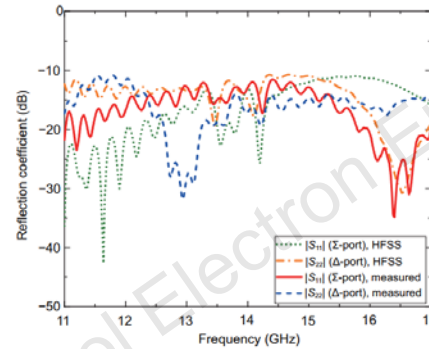

Fig. 11 Simulated and measured reflection coefficients of the Σ -port and Δ -port for the proposed antenna

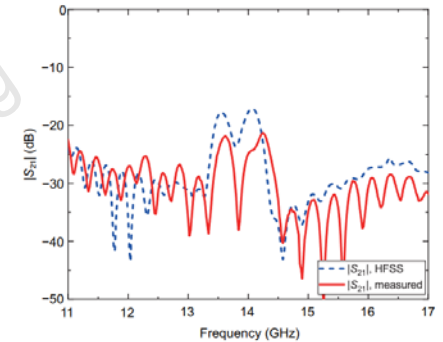

Fig. 12 Simulated and measured isolation between the Σ -port and Δ -port for the proposed antenna

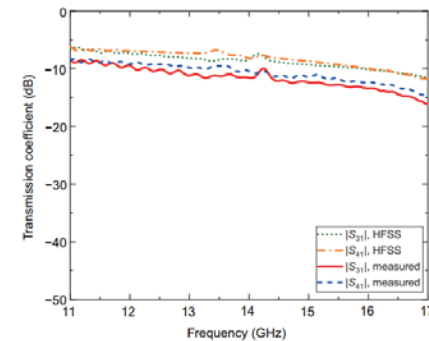

Fig. 13 Simulated and measured transmission coefficients between the Σ -port and the two output ports for the proposed antenna

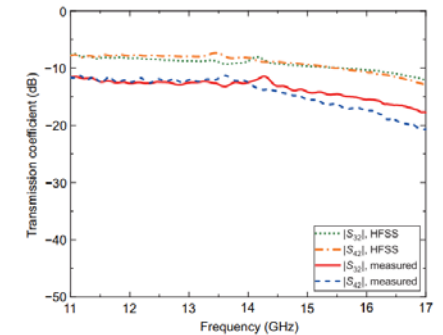
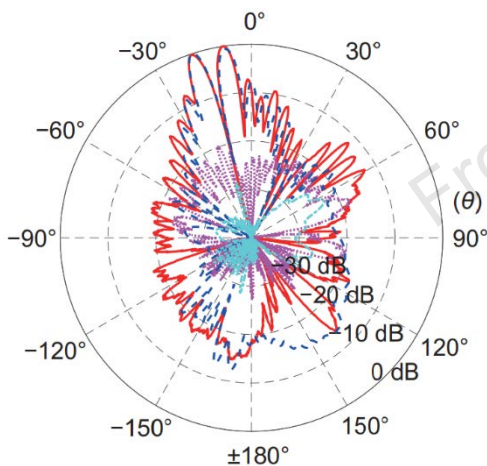
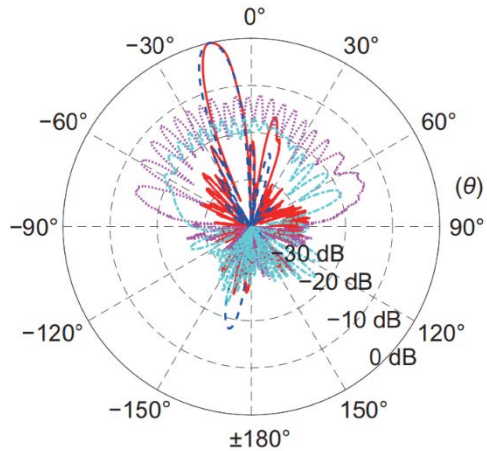

Fig. 14 Simulated and measured transmission coefficients between the Δ -port and the two output ports for the proposed antenna

S parameters for the proposed antenna

Measurement (Cont'd)

Sum beam and difference beam



$f=12.5$ GHz

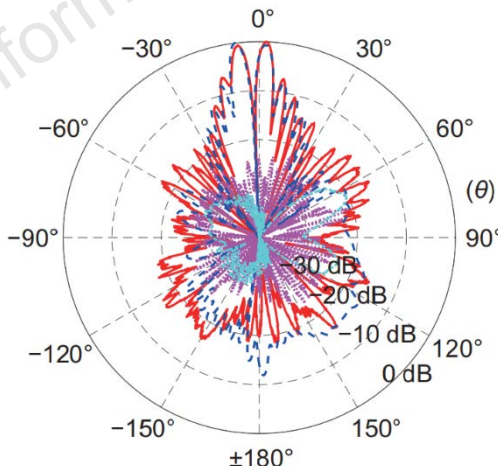
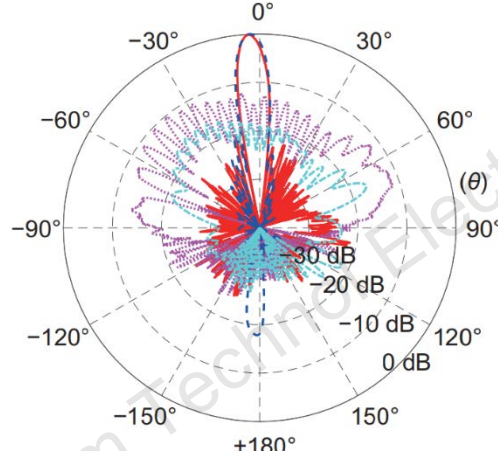

$f=13.5$ GHz

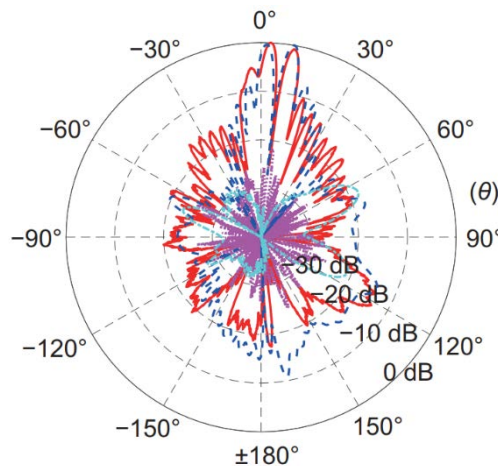
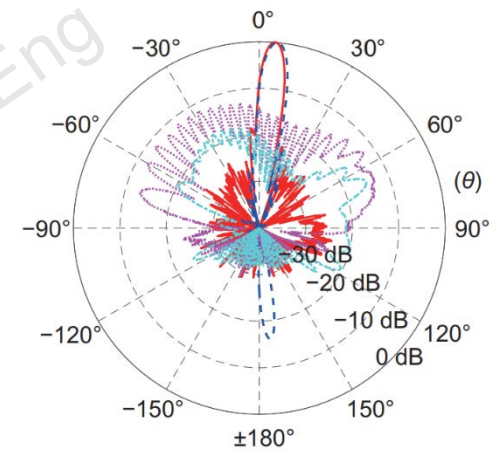

$f=14.5$ GHz

Measurement (Cont'd)

Gain for sum beam

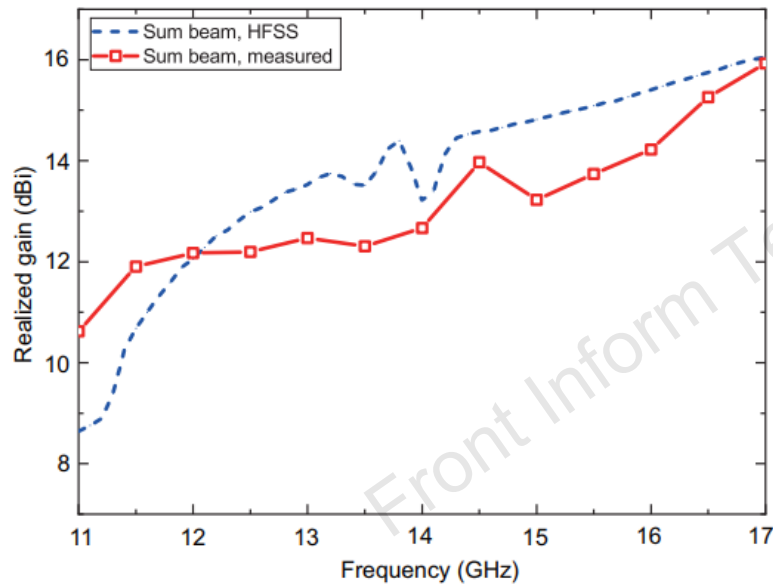

Fig. 17 Simulated and measured realized gains of the sum beam for the proposed antenna

Null depth for difference beam

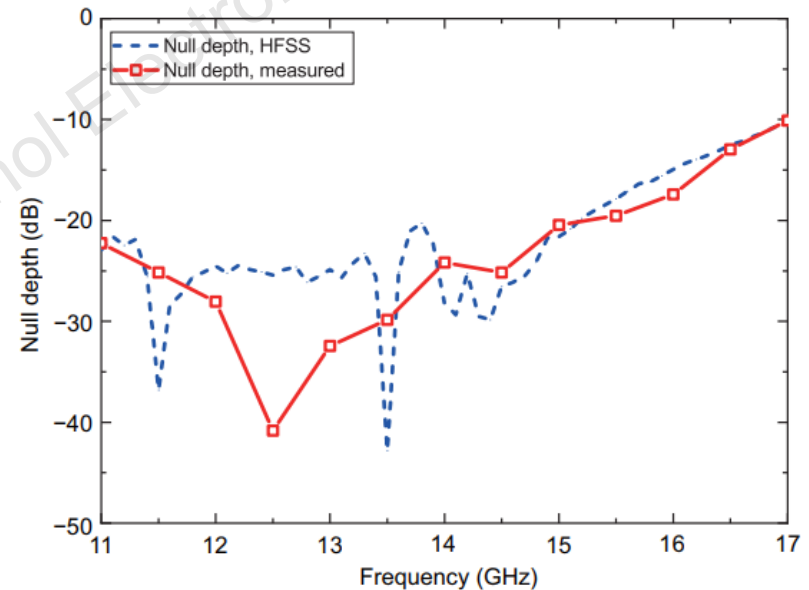

Fig. 19 Simulated and measured null depths for the proposed antenna

Measurement (Cont'd)

Scanning angles

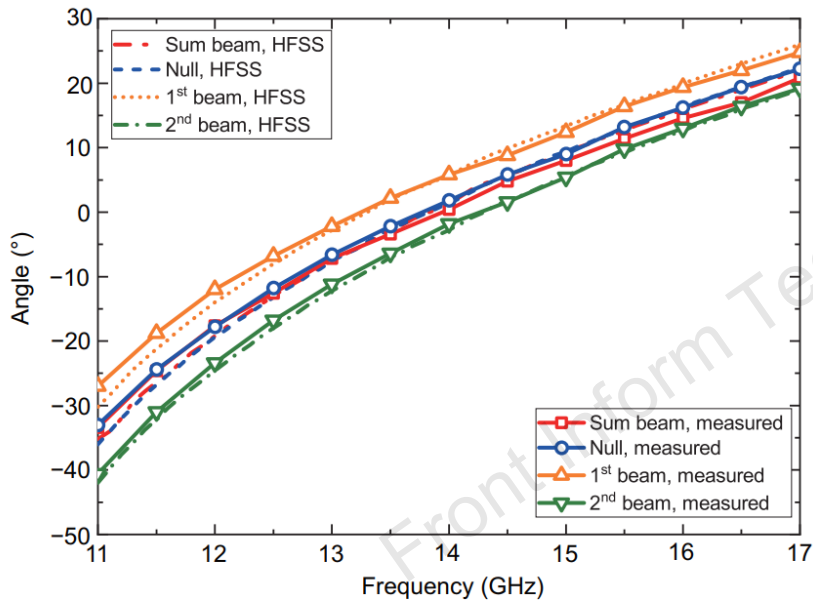

Fig. 20 Angles of the sum beam, null, first beam, and second beam from the simulated and measured radiation patterns

Efficiency

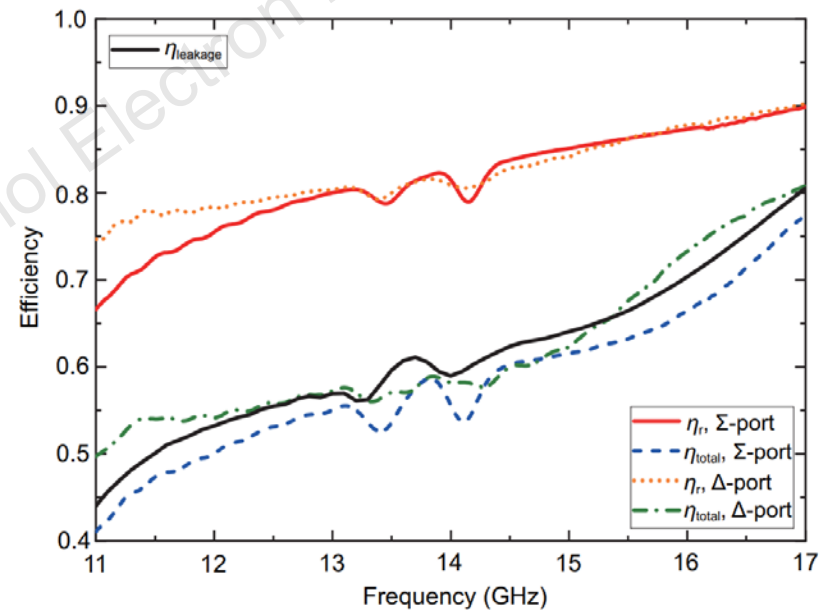

Fig. 21 Leakage efficiency ($\eta_{leakage}$), radiation efficiency (η_r), and total efficiency (η_{total}) for the proposed antenna

Conclusions

- An array of LWAs integrated with 180° hybrid, which has functionality of sum and difference beam scanning, is proposed and can be applied in high-accuracy radar for searching and tracking.
- The sum beam scans from -33.4° to 20.8° in the operating band from 11 to 17 GHz. The angle of null is consistent with the radiation direction of the sum beam.
- The sum beam can reach up to 15.9 dBi and the lowest null depth is -40.8 dB in the operating band.



Mianfeng HUANG received the B.S. degree in electronic engineering from Sun Yat-sen University, Guangzhou, China, in 2020, where he is currently pursuing the M.Eng. degree. His current research interests include leaky-wave antennas and periodic structures.



Juhua LIU is a professor and doctoral supervisor of School of Electronics and Information Technology, Sun Yat-sen University. He received the B.S. and Ph.D. degrees in electrical engineering from Sun Yat-sen University, Guangzhou, China, in 2004 and 2011, respectively. From 2008 to 2009, he was a Visiting Scholar with the Department of Electrical and Computer Engineering, University of Houston, Houston, TX, USA. From September 2011 to September 2012, he was a Senior Research Associate with the State Key Laboratory of Millimeter Waves, City University of Hong Kong, Hong Kong, China. From 2012 to 2015, he was a Lecturer with the Department of Electronics and Communication Engineering, Sun Yat-sen University, where he was an Associate Professor from 2015 to 2022 and has been a Professor since 2022. His research interests include microwave/millimeter wave technology and antennas. He has published more than 80 papers as the first/corresponding author on academic journals of high quality in the field of antenna and microwave.