

Chengmeng LIU, Zhi LI, Guomei WANG, Long ZHENG, 2024. A robust tensor watermarking algorithm for diffusion-tensor images. *Frontiers of Information Technology & Electronic Engineering*, 25(3):384-397.

<https://doi.org/10.1631/FITEE.2200628>

A robust tensor watermarking algorithm for diffusion-tensor images

Key words: Robust watermarking algorithm; Transformer; Image reconstruction; Diffusion tensor images; Soft attention; Hard attention; T1-weighted images

Corresponding author: Zhi LI

E-mail: zhili@gzu.edu.cn

 ORCID: <https://orcid.org/0000-0001-9813-4979>

Motivation

- ❑ Diffusion tensor images (DTIs) are currently the only noninvasive method for visualizing the white matter fiber tracts of the living brain. Medical staff can precisely locate the direction and distribution of brain nerve fiber conduction bundles, providing precise and powerful technical support for the target, enabling entry into the target and path of surgery, reducing damage to brain tissue, allowing medical personnel to observe neural development or damage to the brain, and promptly detecting subtle anomalous changes in the brains of patients with mental illness.
- ❑ So, it is necessary to propose a robust, blind watermarking algorithm to protect the reliability and integrity of DTIs. Currently, there is no robust digital watermarking algorithm for high-dimensional data to effectively protect DTIs.

Main idea

- ❑ A tensor-based watermark-embedding network for DTIs is proposed. In this network, we embed many redundant watermark signals to ensure the robustness of the watermark.
- ❑ T1-weighted (T1w) images are introduced to reduce the distortion level of tensor features because the T1w images have many structural features of the DTIs. The correlation of the T1w images with the tensor features is first calculated using the Transformer. Then, the most relevant features are fused with the tensor features, thus reducing the variation of tensor features.
- ❑ A DTI watermark extraction network that can effectively extract the correct watermark signals from the watermarked DTIs is proposed. A decoding Transformer extracts the relevant watermarking features, and then the watermarking expression of the features is enhanced by deep residual convolution.

Framework and method

- ❑ The framework of the algorithm is shown in Fig. 1. It consists of three main parts:
 - ❑ watermark-embedding network;
 - ❑ watermark extraction network;
 - ❑ attack network.

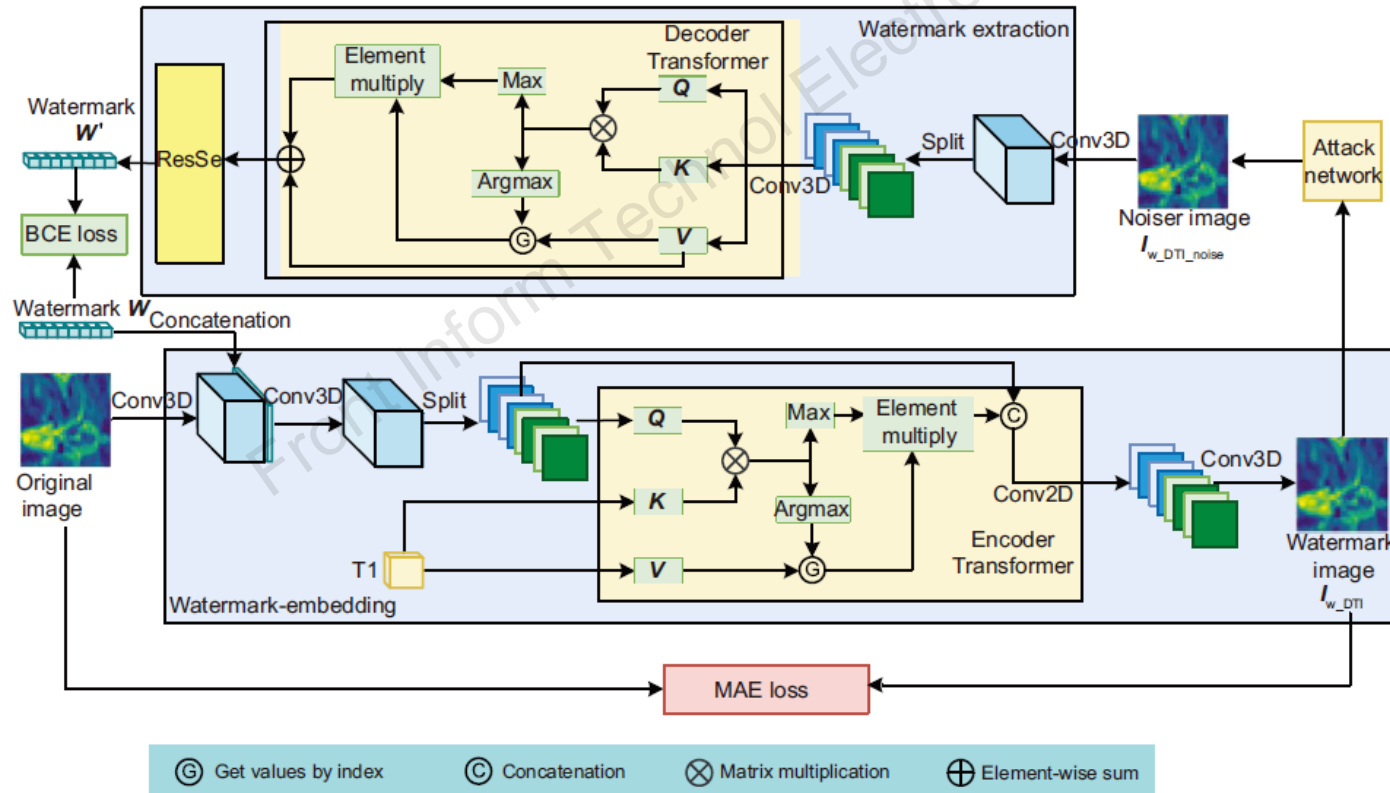

Fig. 1 Network diagram of the robust watermarking algorithm for diffusion tensor images

Framework and method

Watermark-embedding network

The purpose of this network is to embed the watermark signals into the DTIs to obtain the watermarked DTIs I_{w_DTI} and guarantee that I_{w_DTI} still has medical value for clinical diagnosis.

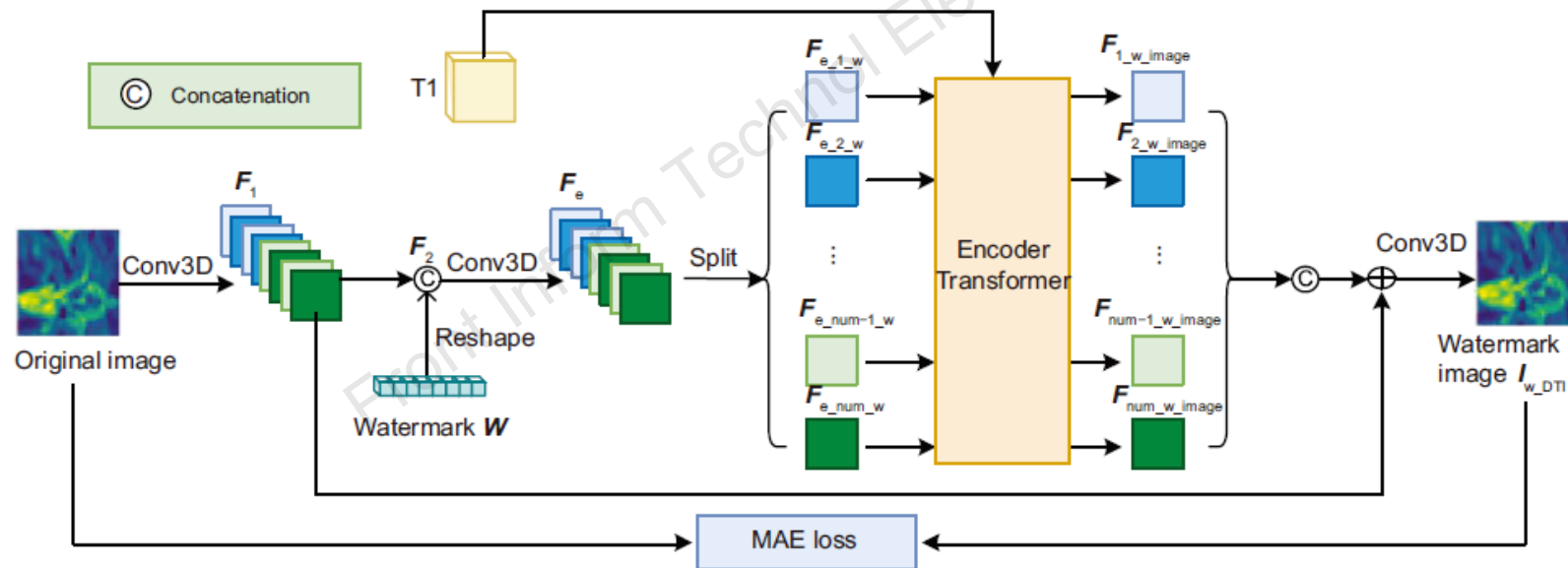

Fig. 2 Watermark-embedding network

Framework and method

□ Attack network:

The main purposes of this network are (1) to perform various attacks on I_{w_DTI} to obtain $I_{w_DTI_noise}$ so that the watermark extraction network can still extract the watermark correctly from $I_{w_DTI_noise}$, and (2) to ensure that the watermark embedded in I_{w_DTI} has high robustness.

Framework and method

Watermark extraction network

This network performs mainly the extraction of watermark signals and correctly extracts the embedded watermark signals from

$I_{w_DTI_noise}$

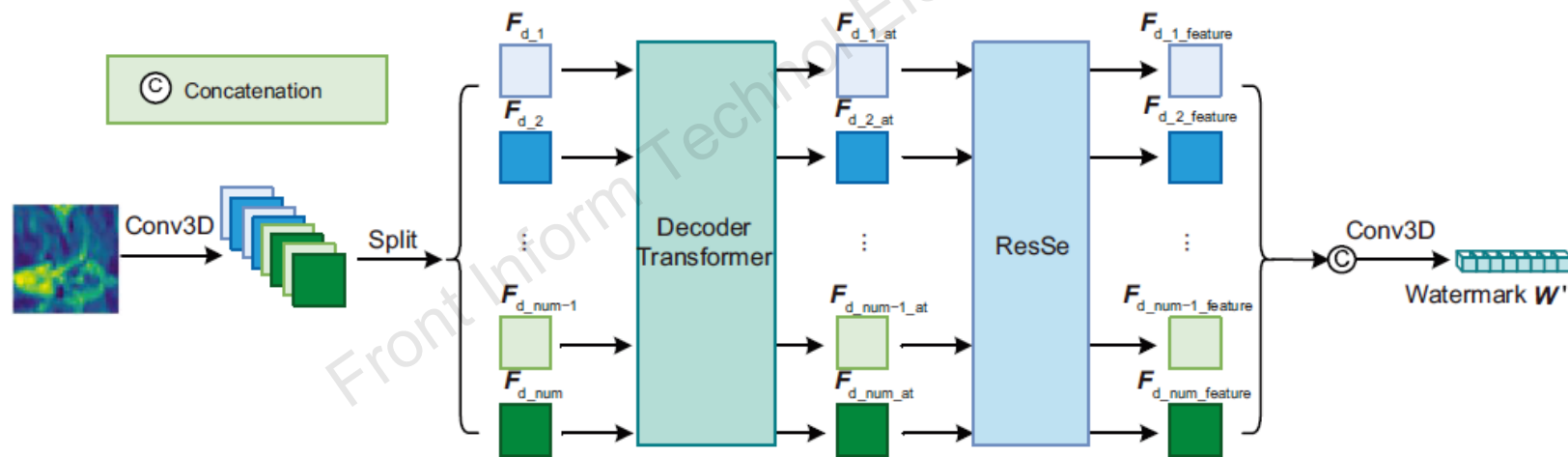

Fig. 4 Network extraction framework diagram

Major results

- The experiments aim to demonstrate three main aspects: (1) verify the algorithm's effectiveness by ablation experiments to find the optimal network structure, (2) verify the clinical value of watermarked DTIs by our proposed algorithm, and (3) verify whether the embedded watermark is highly robust and whether the watermarked DTI can extract the embedded watermark signals through the extraction network after subjecting to various common image attacks.

Table 1 Results of ablation experiments with network width

Num	Average PSNR (dB)	Training time (s)
16	47.93	43 500
32	49.75	81 542
64	50.47	144 836

Num: number of channels of 3D convolution; PSNR: peak signal-to-noise ratio

Table 2 Results of ablation experiments with two- and three-dimensional convolution

Convolution dimension	Average PSNR (dB)
3	39.58
2	41.72

PSNR: peak signal-to-noise ratio

Major results

Table 3 Network width ablation experimental results

Experiment No.	Significant feature module	Soft attention	T1-weighted image	PSNR (dB)
1	×	×	×	39.38
2	×	×	✓	28.15
3	×	✓	✓	41.11
4	✓	×	✓	38.90
5	✓	✓	✓	41.72

PSNR: peak signal-to-noise ratio

Table 4 Comparison of the quality of watermarked DTIs

Serial number	Model	PSNR (dB)	nMSE		PSNR (dB)		α_{AC}
			FA	MD	FA	MD	
1	SuperDTI (Li et al., 2021)	–	0.021	0.001	38.9	38.39	–
2	HiDDeN (Zhu et al., 2018)	29.03	0.096	0.026	24.76	26.17	0.5605
3	Our-num(64)	42.57	0.012	0.00 015	43.44	55.27	0.9385

α_{AC} : main axis deflection angle; DTI: diffusion tensor image; FA: fractional anisotropy; MD: mean diffusivity; nMSE: normalized mean square error; PSNR: peak signal-to-noise ratio

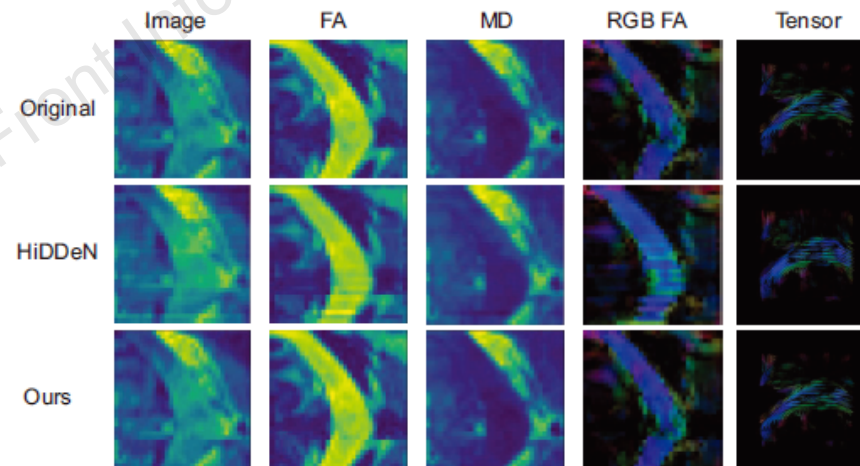

Fig. 7 Results of network width ablation experiments

Conclusions

- This paper solves the problem of robust watermarking algorithms not protecting DTIs. In the watermark-embedding network, there is a large amount of information in the T1w images which is not related to the tensor features. The tensor features in the T1w images need to be extracted by the coding Transformer proposed in this paper for fusion to bring a positive impact on the network. Cross-entropy loss is used in the watermark extraction network, instead of the mean square error loss, to reduce the tolerance of the network to wrong watermark signals. Convolution is introduced in the Transformer to ensure the expressiveness of the feature space while extracting the most significant watermark features. The attention mechanism of the residual channel is used to improve the features' semantic expressiveness and the accuracy of watermark extraction.