

Linna ZHOU, Zhigao LU, Weike YOU, Xiaofei FANG, 2023. Reversible data hiding using a transformer predictor and an adaptive embedding strategy. *Frontiers of Information Technology & Electronic Engineering*, 24(8):1143-1155. <https://doi.org/10.1631/FITEE.2300041>

# Reversible data hiding using a transformer predictor and an adaptive embedding strategy

**Key words:** Reversible data hiding; Transformer; Adaptive embedding strategy

Corresponding author: Weike YOU

E-mail: [ywk@bupt.edu.cn](mailto:ywk@bupt.edu.cn)

 ORCID: Zhigao LU, <https://orcid.org/0000-0002-2215-9843>;  
Weike YOU, <https://orcid.org/0000-0002-2642-6005>

# RDH progress

- The main purpose of reversible data hiding (RDH) is to losslessly restore encrypted images, and in recent years, deep learning methods have been used for RDH.

Date	Event
2010	Chen et al. designed a rhombus predictor, which includes the following two steps: feature selection and feature modification based on difference expansion.
2013	Li et al. presented a high-fidelity reversible data hiding scheme for digital images based on a new prediction strategy called pixel value ordering (PVO) and the well-known prediction error expansion (PEE) technique.
2021	He and Cai calculated the complexity of pixel blocks as the sum of the absolute differences between two consecutive pixels in the horizontal or vertical direction, which first determined pixel blocks to be embedded and then embedded the data according to the embedding strategy.
2021	Hu and Xiang proposed a convolutional neural networks (CNN) predictor (CNNP). The feature extraction step comprises several convolution blocks arranged parallel to exploit multiple receptive fields.

# Tendency and challenges

---

- ❑ In the field of RDH, designing a high-precision predictor to reduce the embedding distortion and developing an effective embedding strategy to minimize the distortion caused by embedding information are the two most critical aspects.

Perhaps what can we do:

- ❑ Use more pixels for prediction
- ❑ Pixels in target blocks may affect the complexity
- ❑ Designing an embedding method that can combine multiple embedding rules

# Motivation

- ❑ RDH has been widely used in scenarios requiring high-quality cover signals, e.g., military communication and health care, as secret data can be embedded into the cover signal without loss.
- ❑ Moreover, combining recent progress on **deep learning**, it is necessary to try CNN or other deep learning technologies to improve the performance of RDH.

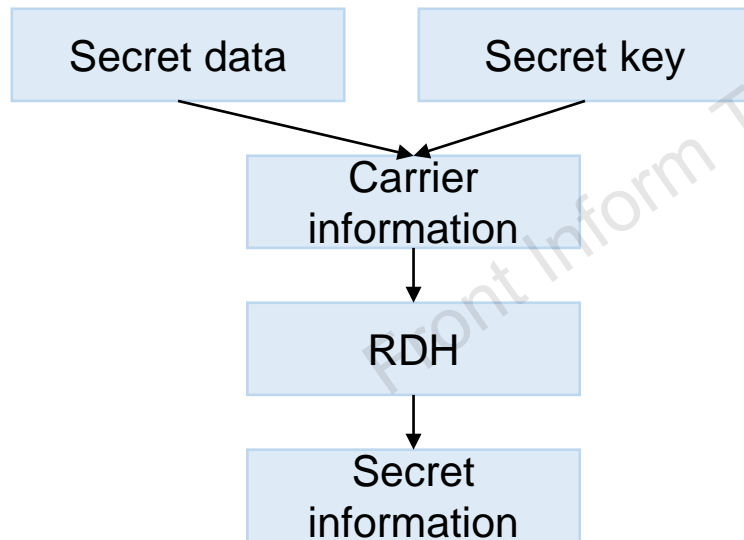

**Embedding process**

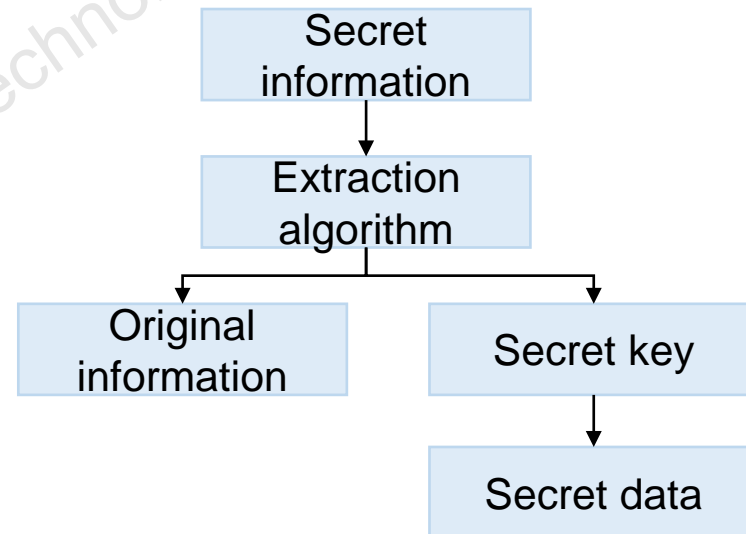

**Extraction process**

# Method

- ❑ The framework of our RDH method is shown as follows:
- ❑ It contains a transformer predictor and an adaptive embedding strategy.

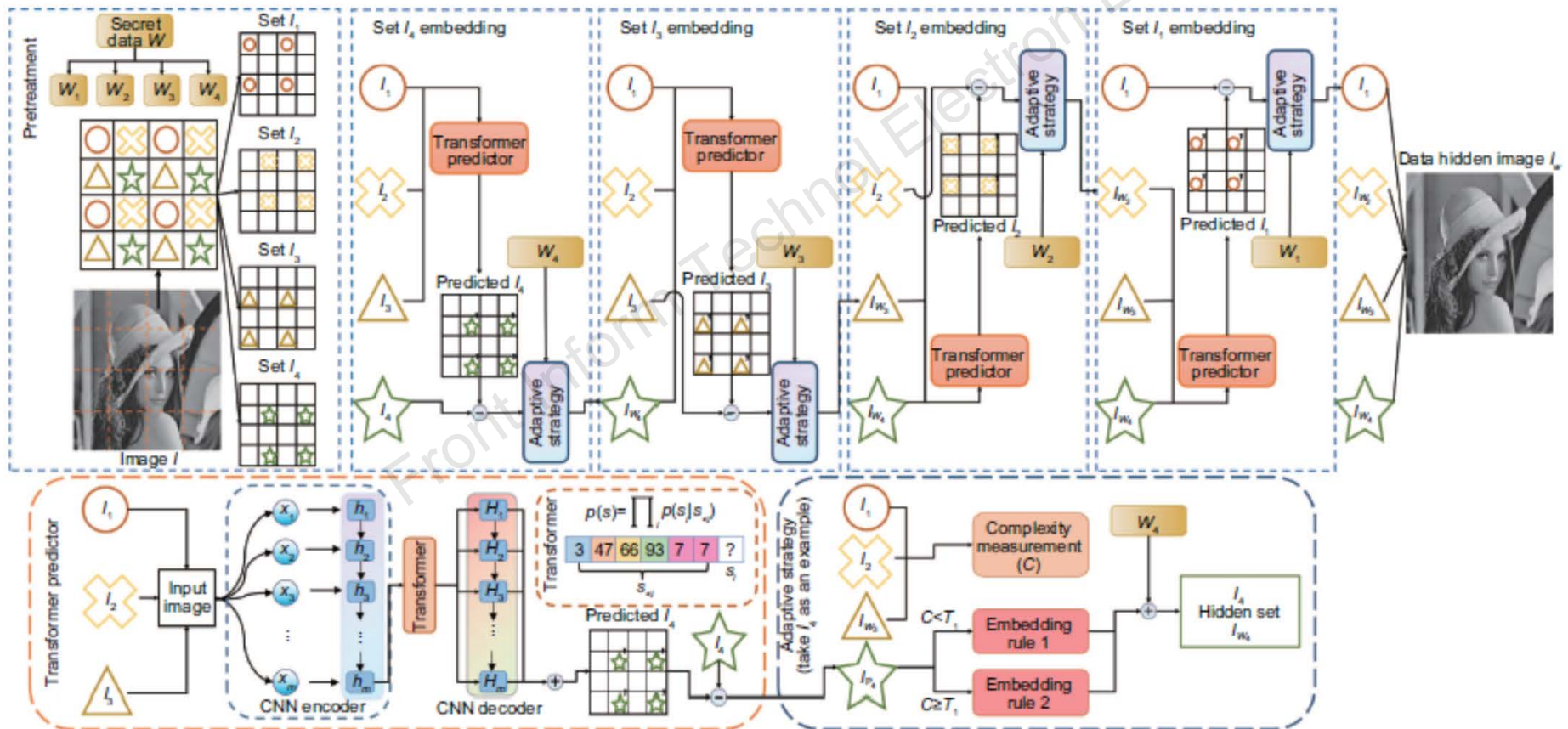

# Predictor

- ❑ An image division method is provided for our predictor to use global pixels for prediction.
- ❑ The predictor is composed of two parts: a convolutional network consisting of an encoder  $E$  and a decoder  $G$ , and a content reasoning module with transformers.

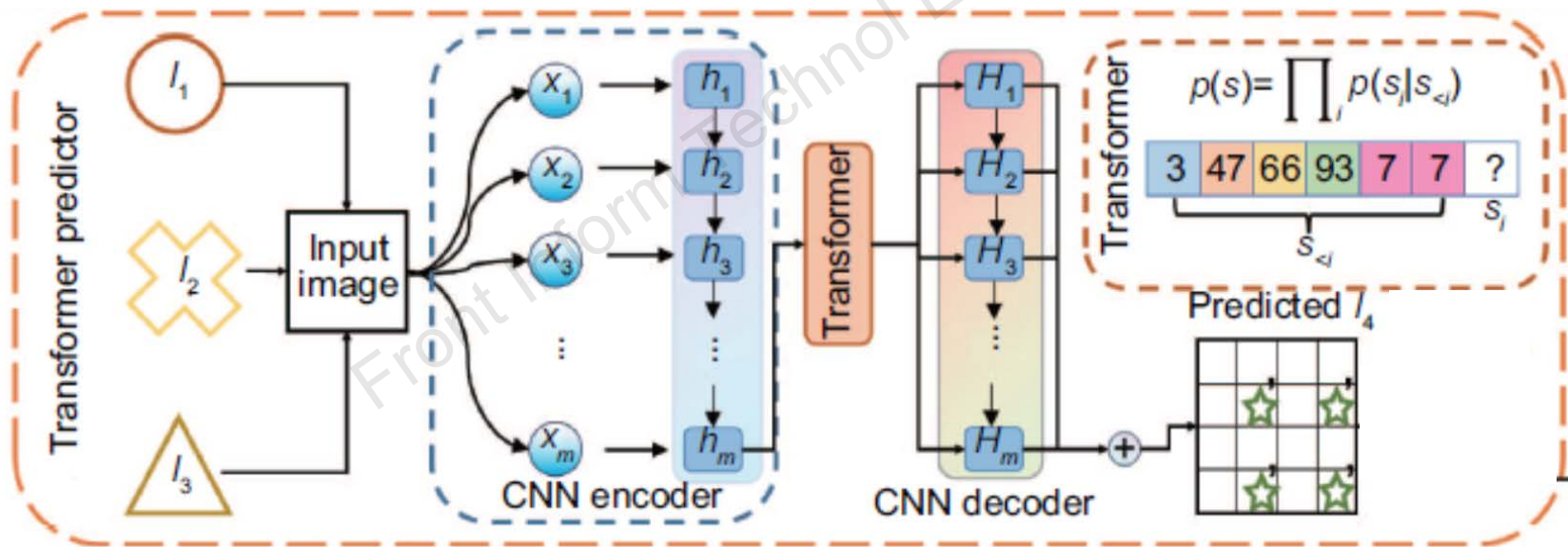

# Embedding strategy

- Our adaptive embedding strategy includes a complexity measurement and multiple embedding rules. The strategy matches appropriate embedding rules for different areas of embedding according to target requirements and reduces embedding distortion.

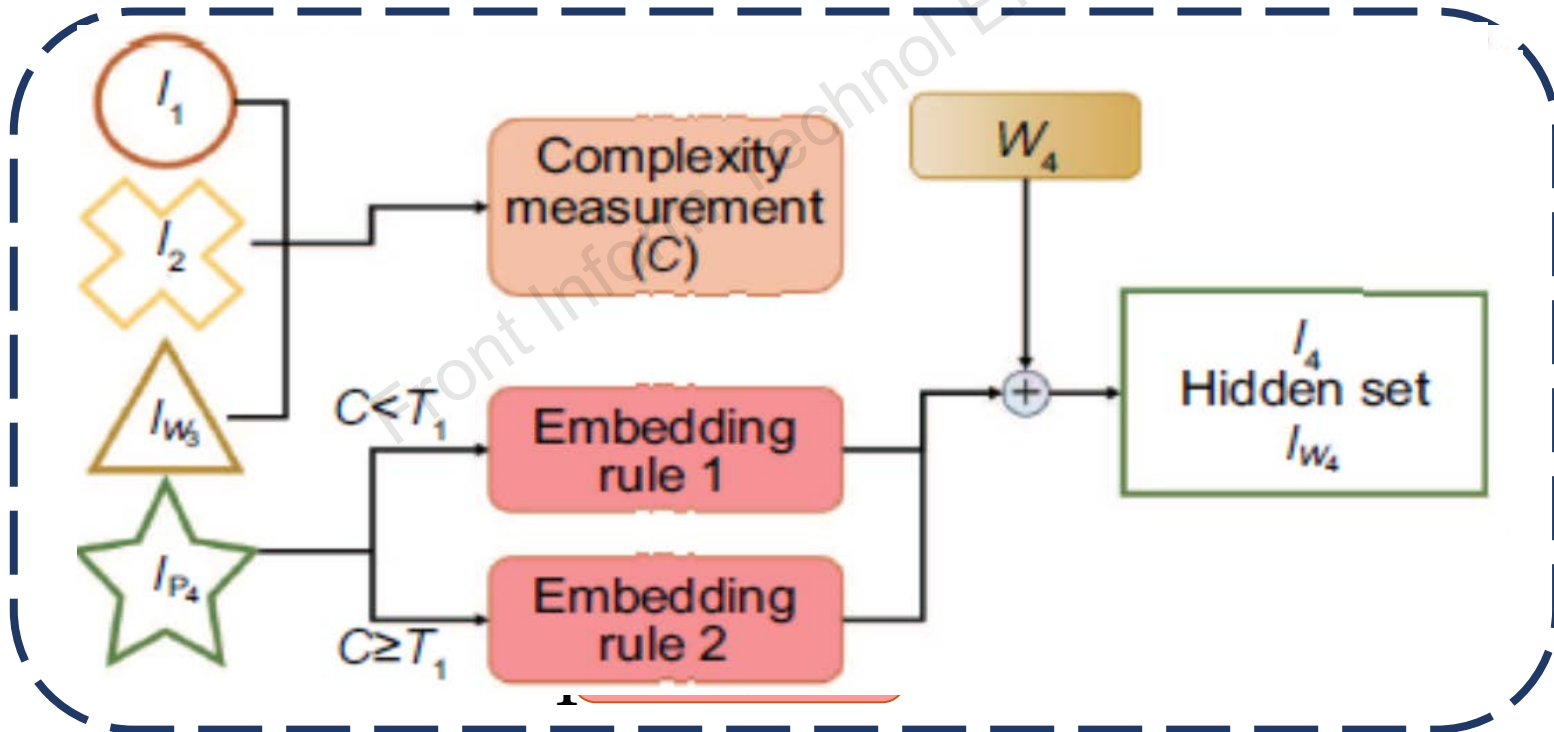

# Experiment

**Table 1 Mean squared error (MSE) of the absolute prediction errors in the test sets under four datasets**

Dataset	MSE		Dataset	MSE
CelebAHQ	41.28		Places2	45.69
FFHQ	38.77		ImageNet	32.46

CelebAHQ: Liu et al. (2015), Karras et al. (2018); FFHQ: Karras et al. (2019); Places2: Zhou et al. (2018); ImageNet: Rusakovsky et al. (2015)

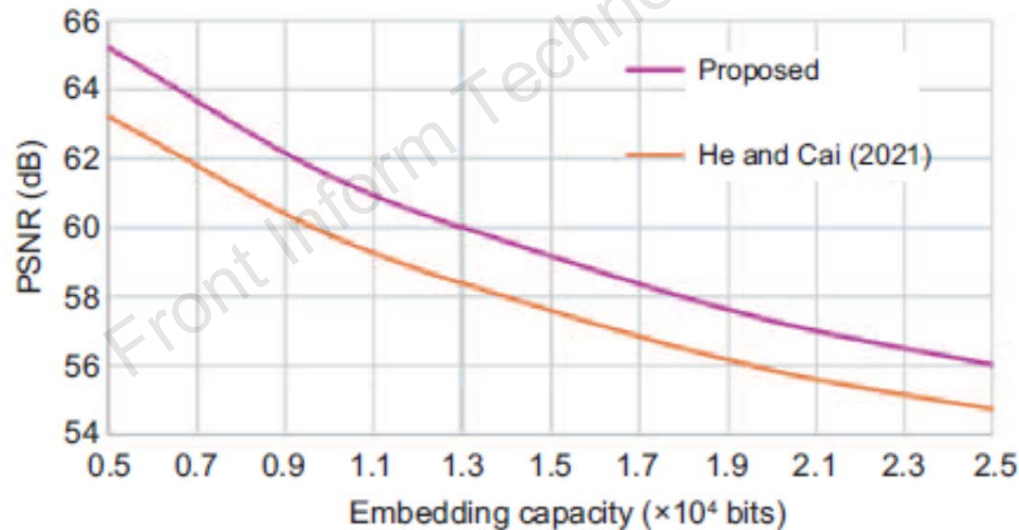

**Fig. 9 Comparison of complexity measurements between our work and He and Cai (2021) (PSNR: peak signal-to-noise ratio)**

# Experiment (Cont'd)

**Table 2** Peak signal-to-noise ratio (PSNR) values of six classic images of the test set generated by the proposed reversible data hiding (RDH) method, CNN PEO, LPVO, dual pairwise PEE, pairwise IPVO, and pairwise PEE with embedding capacity of 10 000 or 20 000 bits

Image	PSNR (dB), embedding capacity 10000 bits					
	Ours	CNN PEO	LPVO	Dual pairwise PEE	Pairwise IPVO	Pairwise PEE
Lena	62.25	61.70	61.24	61.21	60.87	59.77
Barbara	62.79	62.23	61.35	61.17	60.71	59.49
Boat	60.36	59.81	59.32	59.14	58.41	57.56
Elaine	60.70	59.55	59.18	58.90	58.16	58.10
Lake	61.88	61.24	60.60	60.65	59.98	58.67
Peppers	61.04	60.10	59.97	59.61	59.35	56.25
Average	61.50	60.77	60.28	60.11	59.58	58.31

Image	PSNR (dB), embedding capacity 20000 bits					
	Ours	CNN PEO	LPVO	Dual pairwise PEE	Pairwise IPVO	Pairwise PEE
Lena	58.58	57.96	57.74	57.68	57.12	56.29
Barbara	59.13	58.54	57.35	57.41	56.78	56.25
Boat	56.29	55.72	54.97	55.00	54.19	53.37
Elaine	55.70	54.93	54.33	54.18	53.43	52.92
Lake	57.10	56.47	55.63	55.85	54.84	53.76
Peppers	57.01	55.83	55.98	56.00	55.35	52.86
Average	57.30	56.58	56.00	56.02	55.29	54.24

CNN PEO: Hu and Xiang (2022); LPVO: Zhang et al. (2020a); dual pairwise PEE: He and Cai (2021); pairwise IPVO: Dragoi et al. (2018); pairwise PEE: Ou et al. (2013). CNN: convolutional neural network; PEO: prediction error ordering; LPVO: location-based pixel value ordering; PEE: prediction error expansion; IPVO: improved pixel value ordering

# Conclusions

1. In this paper, we proposed a new RDH method, including a transformer predictor and an adaptive embedding strategy. Experimental results have shown that the embedding performance of the proposed RDH method was satisfactory and better than those of the current state-of-the-art works. For the test images, the average PSNR was 61.50 dB after hiding 10 000 bits.
2. In future works, we consider that there is room for improvement of the prediction performance using better deep learning methods as predictors and designing more effective strategies.



Linna ZHOU is a professor of Beijing University of Posts and Telecommunications, graduated from Beijing University of Posts and Telecommunications with a PhD degree from Tsinghua University. She is the recipient of State Council Special Allowance and the head of the National Key Areas Innovation Team. She has been selected into the National Million Talents Project and awarded the honorary title of "Young and Middle-aged Experts with Outstanding Contributions." Besides, she has served as a committee or member of national associations. She has published many academic papers and four monographs in related research fields. She has presided over and completed three key and general projects of National Natural Science Foundation of China (NSFC), three National Key Scientific Research Projects, and more than dozens of major scientific research projects at the ministerial level. She has won the second prize of National Science and Technology Progress Award in 2006, the second prize of National Science and Technology Progress Award in 2009, the second prize of National Science and Technology Progress Award in 2016, and the second prize of National Science and Technology Progress Award in 2019. In 2011, she won the first prize of National Science and Technology Progress Award.



Zhigao LU received his BE degree from the University of International Relations, Beijing, China, in 2020. His research interests include multimedia security and AI-generated technologies.



Weike YOU earned her BE degree from Beijing University of Posts and Telecommunications, and later completed her PhD degree at the Chinese Academy of Sciences. Currently, she serves as a faculty member at Beijing University of Posts and Telecommunications, focusing her research on multimedia security and AI-generated technologies.



Xiaofei FANG is currently studying in the University of International Relations, majoring in data science and big data technology.