

Miaoran PENG, Jinhao KAN, Lixia XIAO, Guanghua LIU, Tao JIANG,
2023. Digital-to-analog converter free architecture for digital
reconfigurable intelligent surface. *Frontiers of Information Technology
& Electronic Engineering*, 24(12):1752-1762.

<https://doi.org/10.1631/FITEE.2300133>

Digital-to-analog converter free architecture for digital reconfigurable intelligent surface

Key words: Reconfigurable intelligent surface; Hardware
implementation; High-order modulation

Corresponding author: Lixia XIAO

E-mail: lixiaxiao@hust.edu.cn

 ORCID: <https://orcid.org/0000-0001-7959-8356>

Motivation

1. Owing to the potential benefits of multiple paths generated by the large-scale elements, reconfigurable intelligent surface (RIS) structure tends to exhibit considerable potentiality in wide-area coverage and terahertz communication.
2. The **power consumption** of a single RIS element reaches the mW-level, with the result that the power consumption of a RIS structure reaches the W-level after the integration of hundreds of elements, a phenomenon that runs contrary to the original intention underlying passive communication.
3. The use of a **voltage grading method** is the currently prevailing state-of-the-art technical recommendation for the division of different constellation points, but the voltage regulation range is limited.

Method

Even as the number of RIS elements increases, the proposed architecture maintains power consumption at a low level.

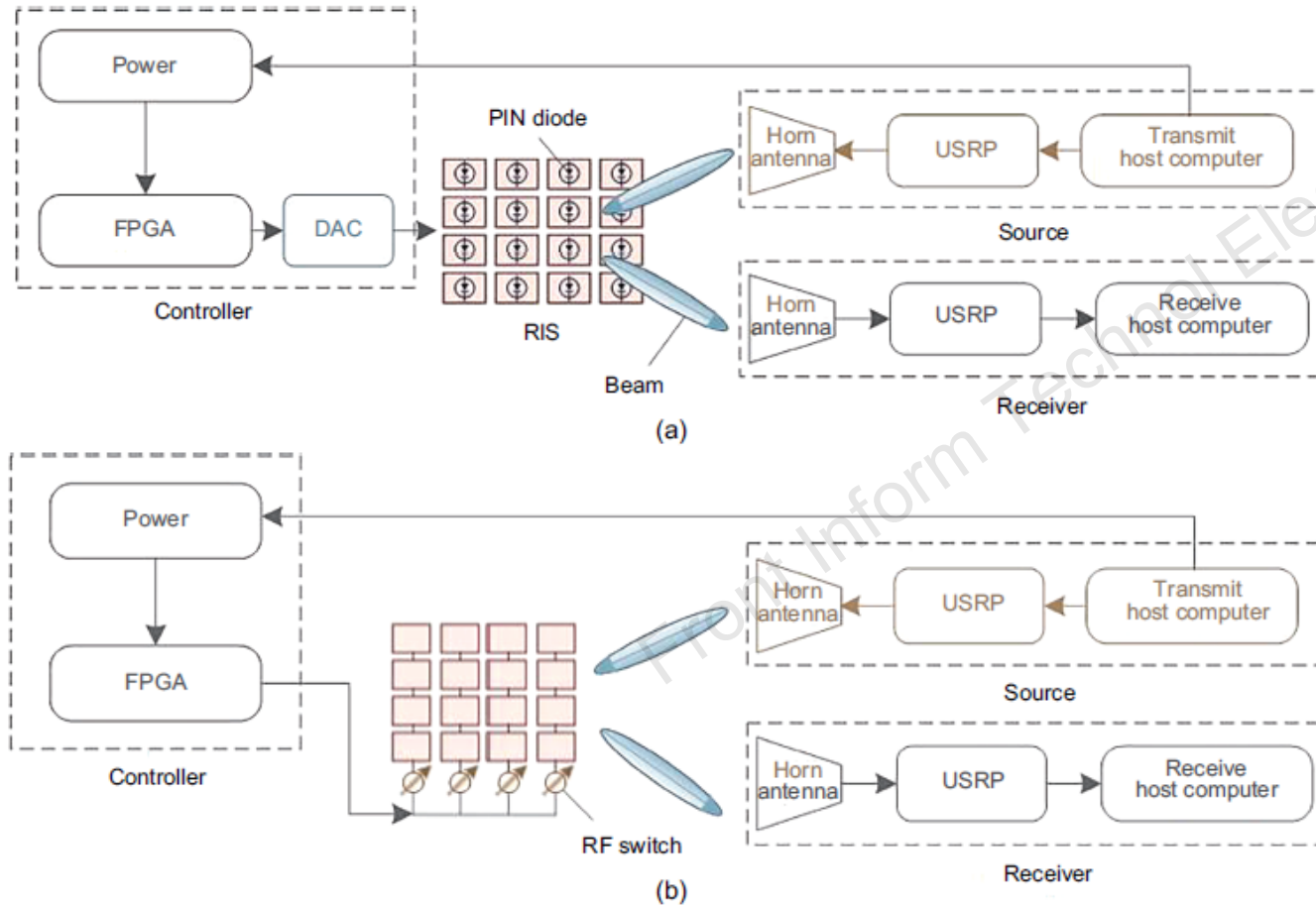

Table 1 Power comparison among an active RIS, a traditional passive RIS, and the proposed RIS structure

Core component	Power		
	Active	Traditional	Proposed
Patch/Metamaterial	0	0	0
DAC	1 mW	1 mW	
PIN diode	250 mW	250 mW	
RF switch			1 μ W
Amplifier	1.2 W		
FPGA	300 μ W	300 μ W	300 μ W

Fig. 1 System structure: (a) a traditional system structure of digital RIS; (b) the proposed DAC-free system structure of digital RIS

Method

Transmission line based phase shifter design: easy for adjustment and high precision

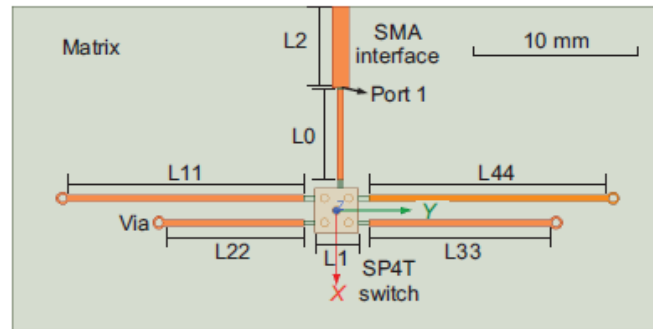

(a)

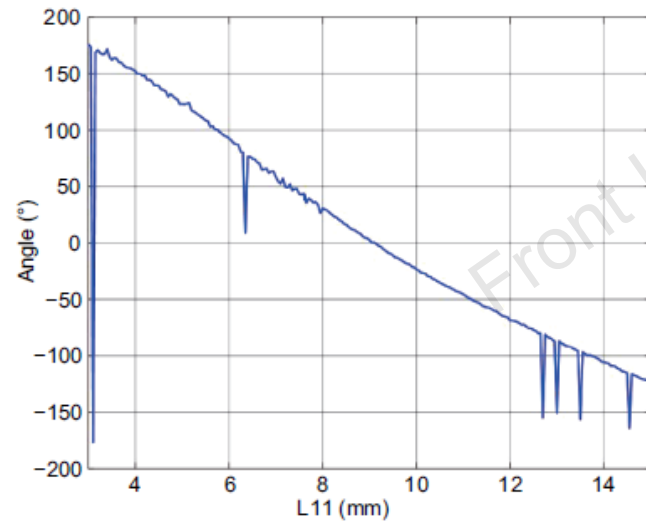

(b)

Fig. 2 HFSS model of the 2-bit phase shifter: (a) HFSS model of the SP4T switch and phase shifter; (b) simulation results of the phase angle

Table 2 Parameter settings

Parameter	Value	Description
T	35 μm	Thickness of the immersion gold
H	0.203 mm	Media thickness
W50	0.359 mm	Width of the 50- Ω transmission line
L1	2.7 mm	Pad length of the SP4T switch
L2	5 mm	Pad length of the SMA interface
R1	10 mil	Inner diameter of the via
R2	15 mil	Outer diameter of the via
L11	5.2 mm	
L22	11.3 mm	Simulation results of the lengths
L33	8.7 mm	of the transmission lines
L44	14.65 mm	

Method

High-order modulation scheme: 16-QAM with four reflection coefficients

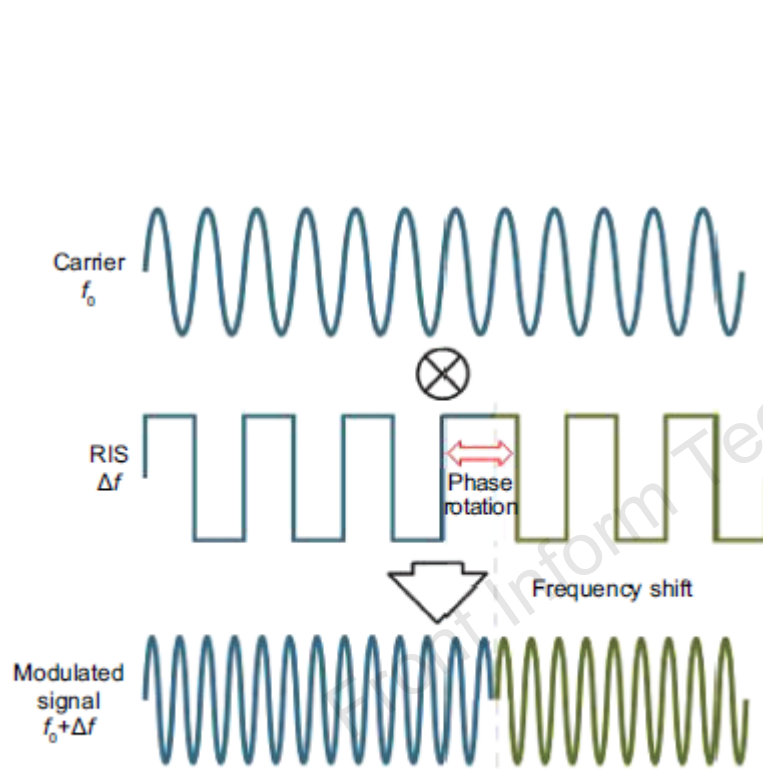

Fig. 3 Modulation principle

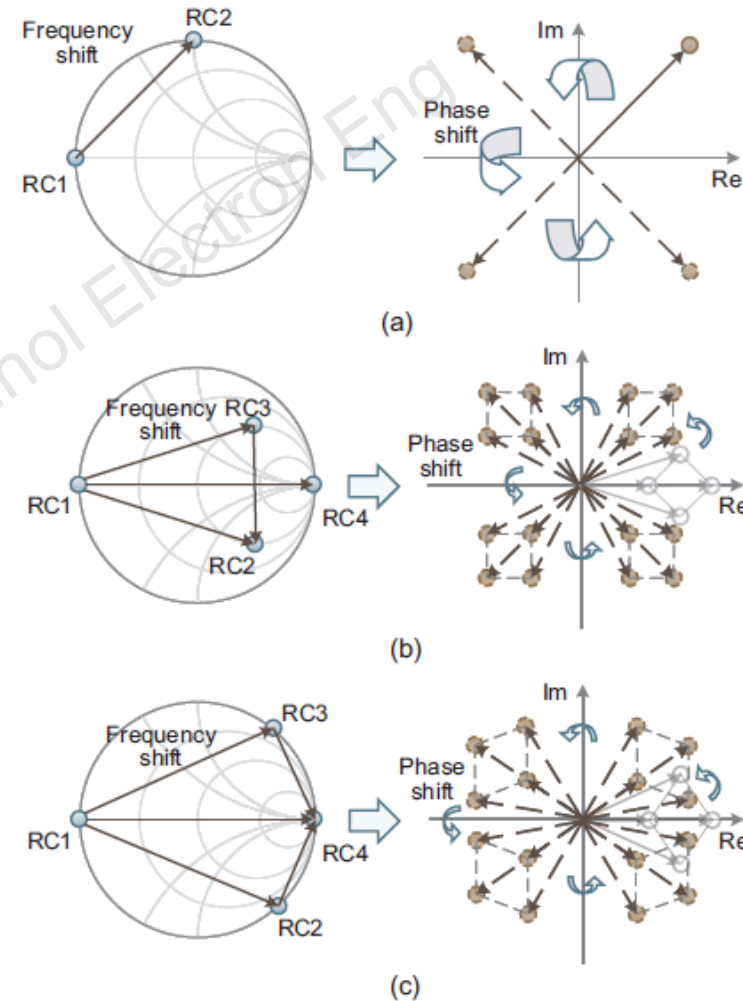

Fig. 4 High-order modulation scheme: (a) QPSK; (b) standard 16-QAM; (c) near-standard 16-QAM

Method

Simulations and experiments: a 4*4 digital RIS for 16-QAM transmission

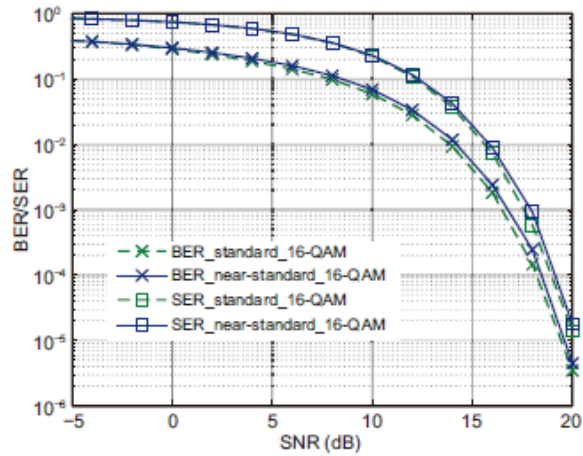

Fig. 6 BER and SER performances of the proposed modulation method

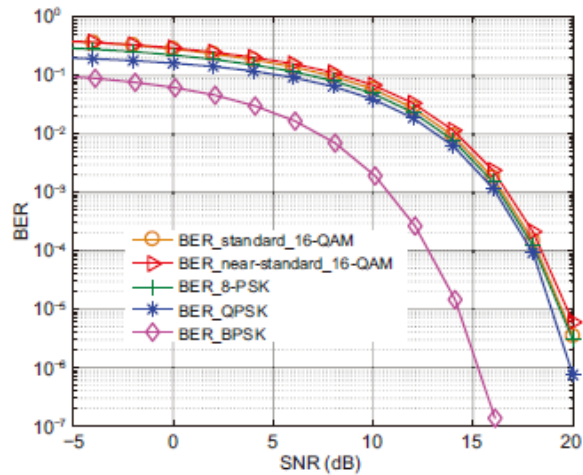
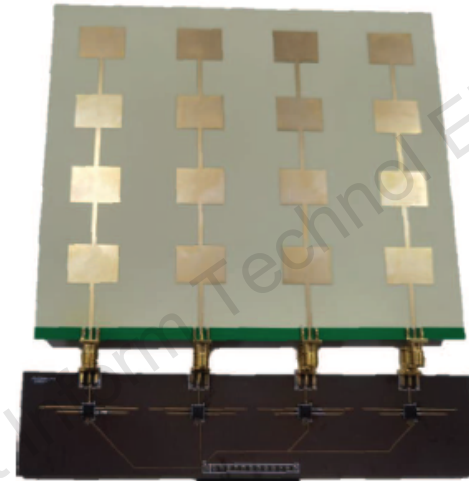
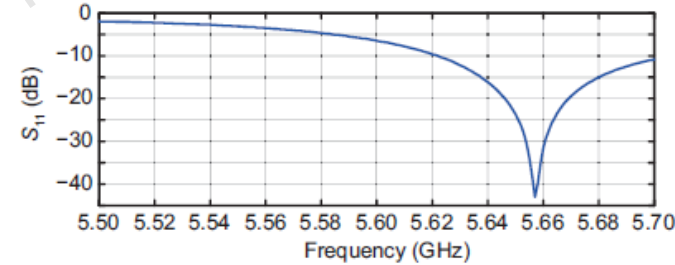

Fig. 7 Comparison of the proposed scheme and traditional schemes



(a)



(b)

Fig. 8 Prototype of the proposed RIS structure (a) and S_{11} of RIS elements (b)



Fig. 9 Test scenario

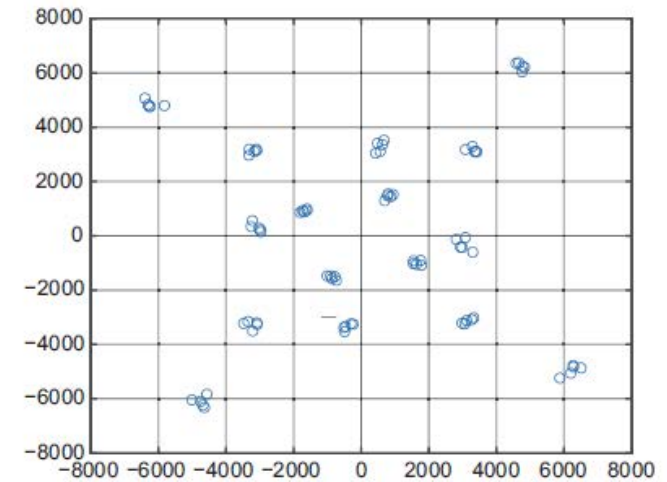

Fig. 10 Demodulation results

Conclusions

1. We proposed a DAC-free architecture for digital RIS structure.
2. We analyzed high-precision phase shifters and novel high-order modulation schemes for the proposed architecture.
3. Simulation and experimental results confirm the feasibility of the proposed algorithm.



Miaoran PENG received the B.S. degree from South East University (SEU), Nanjing, China, in 2020. She is currently pursuing the Ph.D. degree with the Research Center of 6G Mobile Communications, Huazhong University of Science and Technology. Her research interests include reconfigurable intelligent surface and backscatter communication of wireless communication systems.



Lixia XIAO received the B.E., M.E., and Ph.D. degrees from the UESTC in 2010, 2013, and 2017, respectively. From 2016 to 2017, she was a visiting student with the School of Electronics and Computer Science, University of Southampton. From 2018 to 2019, she has been a Research Fellow with the Department of Electrical Electronic Engineering, University of Surrey. She is currently a Full Professor with the Research Center of 6G Mobile Communications, Huazhong University of Science and Technology. She works mainly on key technologies of the physical layer, including massive MIMO design, deep learning based signal processing, and new multi-carrier transmission.