

Bing Li, Peng YANG, Yuankang SUN, Zhongjian HU, Meng YI, 2024.
Advances and challenges in artificial intelligence text generation.
Frontiers of Information Technology & Electronic Engineering,
25(1):64-83. <https://doi.org/10.1631/FITEE.2300410>

Advances and challenges in artificial intelligence text

Key words: AI text generation; Natural language processing;
Machine learning; Deep learning

Corresponding author: Peng YANG

E-mail: pengyang@seu.edu.cn

 ORCID: <https://orcid.org/0000-0002-1184-8117>

Motivation

1. Text generation is an essential research area in artificial intelligence (AI) technology and natural language processing, and provides key technical support for the rapid development of AI-generated content (AIGC).
2. Text generation is based on technologies such as natural language processing, machine learning, and deep learning, which enable learning language rules through training models to automatically generate text that meets grammatical and semantic requirements.
3. We summarize some specific manifestations to increase future researchers' systematic understanding of the directions and cutting-edge technological developments in intelligent text generation.

Method

Generative content production and distribution enables the utilization of AI for creation and production, changing the traditional manner in which content is produced by humans.

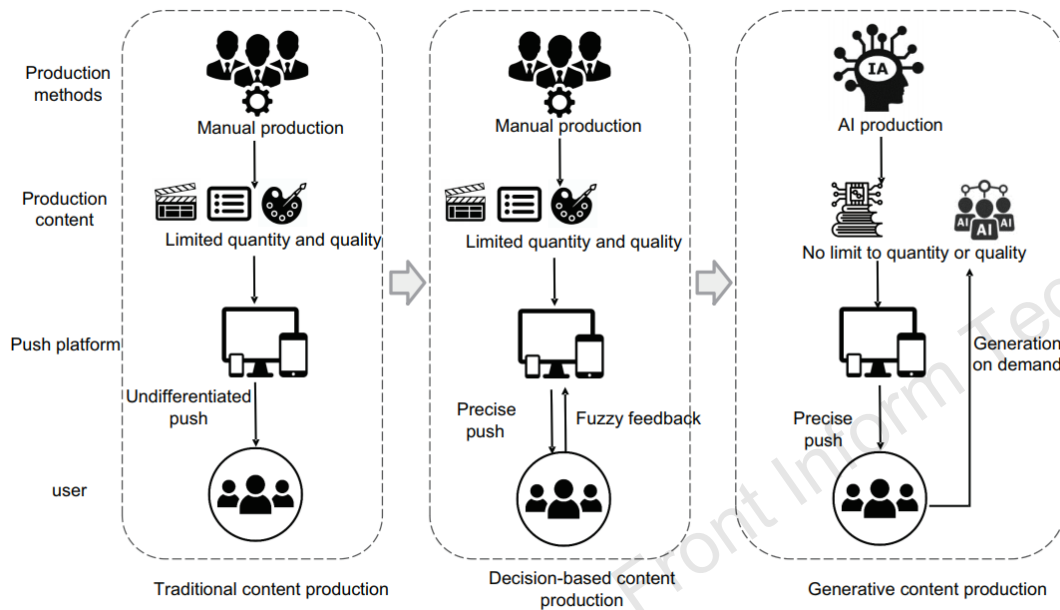

Fig. 1 Different content production methods

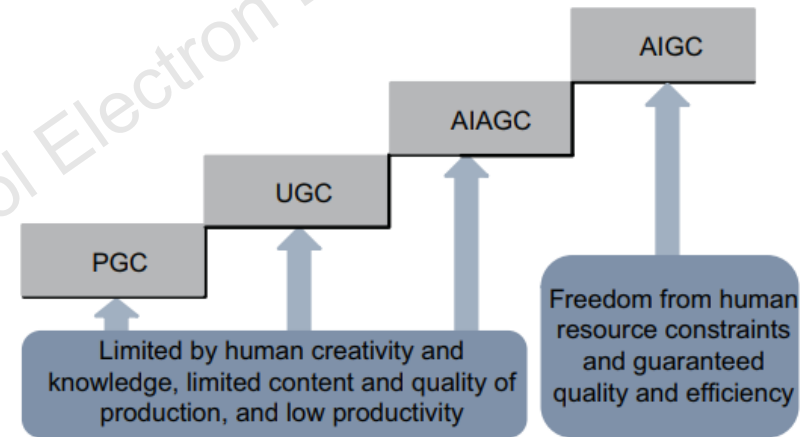

Fig. 2 Four stages of content generation

Table 1 Comparison of the characteristics of three different types of text generation

Category	Efficient	Customizability	Innovative	Artistry	Adaptive	Diversity
Utility text generation	Yes	Yes	No	No	Yes	Yes
Creative text generation	Yes	No	Yes	Yes	Yes	Yes
Emotive text generation	Yes	Yes	Yes	No	Yes	Yes

Method

The frequency-based text generation method

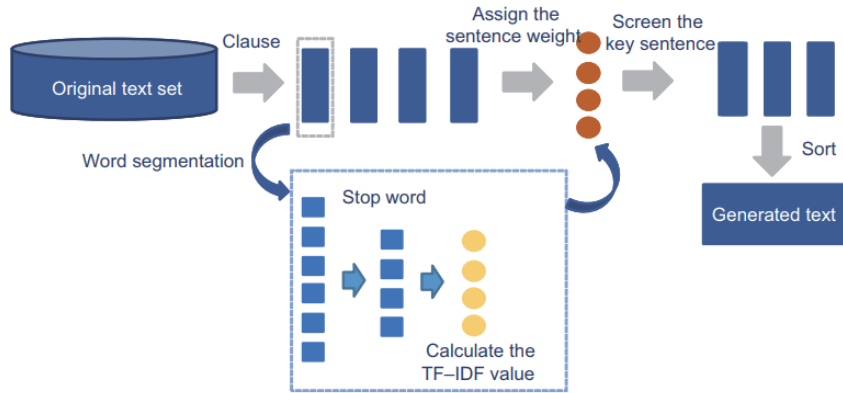

Fig. 3 Breakdown of the methodological steps of word frequency statistics

Encoder–decoder-based text generation method

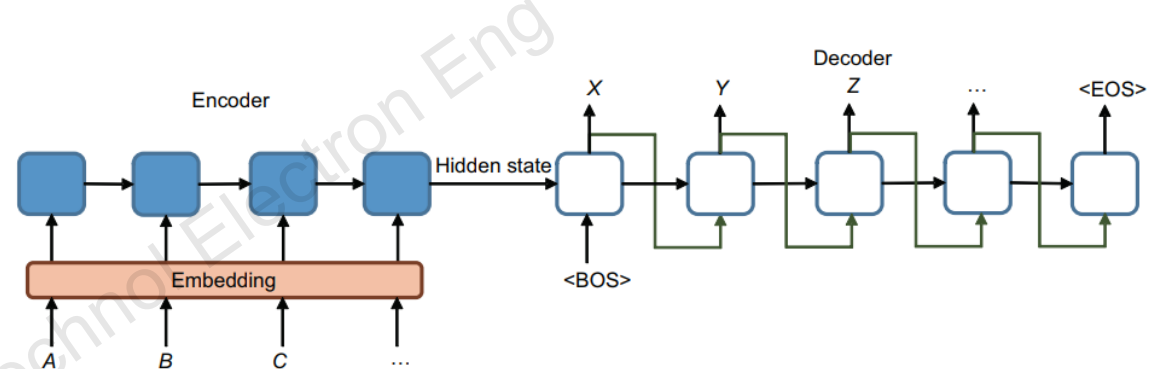

Fig. 5 Schematic of the Seq2Seq model

Seq2Seq model based on the Transformer

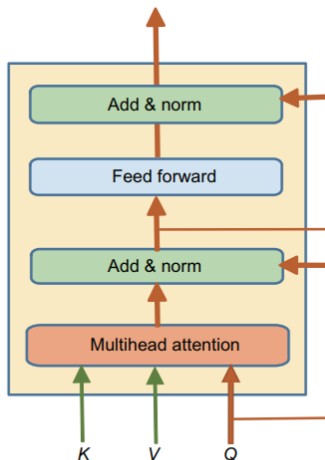

Fig. 6 Encoding structure of the Transformer

Pre-trained language model based text generation method

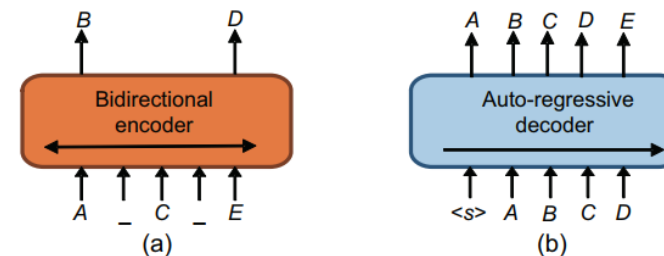

Fig. 7 Encoder-only (a) and decoder-only (b) model schematics

Method

To analyze and explore the relationship between different methods more intuitively, the following chart compares the advantages and disadvantages of the four methods:

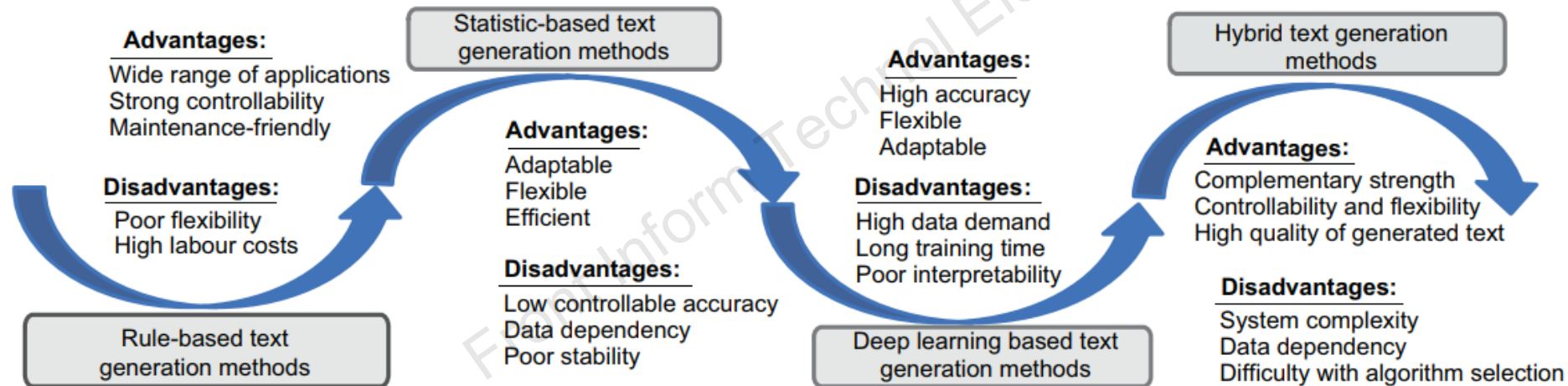

Fig. 8 Comparison of advantages and disadvantages between different methods

Method

Several representative text generation products and the corresponding product features

Table 5 News-related system

Application	R&D unit	Introduction
GPT-3	OpenAI	The product generates natural and fluent language, and it is capable of engaging in dialogue, translation, summary, Q&A, and many other tasks. Some news organizations are already experimenting with GPT-3 to automatically generate news releases
AI Writer	36Kr	The application automatically generates press releases, reviews, stories, and other content. AI Writer is characterized by speed, efficiency, and accuracy
WordSmith	Automated Insights	The system works to generate content for press releases, financial report analysis, etc. The system automatically analyzes data and generates natural language text abstracts
Quill	Automated Insights	The application is designed to generate text for sports, business, finance, and other fields. The system works with natural language generation techniques to generate high-quality text content
Heliograf	Washington Post	The software automates the generation of simple news releases, such as event reports and election results

Table 6 Representative text generation products

Application	R&D unit	Product feature
ChatGPT	OpenAI	Text generation, summarizing, and answering questions
InstructGPT	OpenAI	Text generation, summarizing, and answering questions
Jasper	Jasper.ai	Writing blog posts, social media posts, and website copy
Copi.ai	Copi.ai	Text generation, chatbots, sentiment analysis, and customer support automation
CopySmith	CopySmith	Creating marketing copy, product descriptions, and advertising copy
Boost Sport AI	ARRIA	Performance analysis, creation of advertising copy, and dialogues

Prospective trends and Conclusions

1. Enhanced quality and quantity of text generation.
2. Social and interactive text generation.
3. Data-based natural language generation.
4. Multilingual text generation.
5. Adaptive text generation.

Prospective trends



Conclusions



1. We provide an overview of the main forms of text generation and some recent research advances.
2. We present an objective analysis of the application areas and challenges faced by text generation.
3. We propose an overview of several future research trends.



Bing LI obtained the MS degree from Taiyuan University of Technology in 2019. Currently, she is pursuing her PhD degree at the School of Computer Science and Engineering and the Key Laboratory of Computer Network and Information Integration, Ministry of Education, Southeast University, China, with the research focus on artificial intelligence, natural language processing, image processing, and associated domains.



Peng YANG received the PhD degree from Southeast University, in 2006, by taking a successive postgraduate and doctoral program. He worked as a Research Scientist with CERN participating in the Alpha Magnetic Spectrometer (AMS) experiment (PI: Nobel laureate Samuel C.C. Ting), from 2007 to 2009. He is currently a Professor at the School of Computer Science and Engineering, Southeast University, where he is also the Deputy Director of the Future Network Research Center. His research interests focus on new-generation network architecture, edge computing, natural language processing, blockchain, and cyber content governance. He is a member of the National Technical Committee of Standardization Administration of China.