

Yang YANG, Fanming HUANG, Dong YUE, 2025. Reinforcement learning based privacy-preserving consensus tracking control of nonstrict-feedback discrete-time multi-agent systems. *Frontiers of Information Technology & Electronic Engineering*, 26(3):456-471.

<https://doi.org/10.1631/FITEE.2300532>

Reinforcement learning based privacy-preserving consensus tracking control of nonstrict-feedback discrete-time multi-agent systems

Key words: Multi-agent systems; Consensus tracking; Privacy-preserving; Reinforcement learning

Corresponding author: Dong YUE

E-mail: medongy@vip.163.com

 ORCID: <https://orcid.org/0000-0001-7810-9338>

Motivation

- The existing Liu cryptosystem uses a large number of random sequences to create a ciphertext. Actually, although these random numbers increase data privacy, they lead to a decryption error between a plaintext and a decrypted plaintext. There is still a lack of theory for improving decryption performance. Further technique is thus necessary to mitigate decryption errors arising from random numbers.

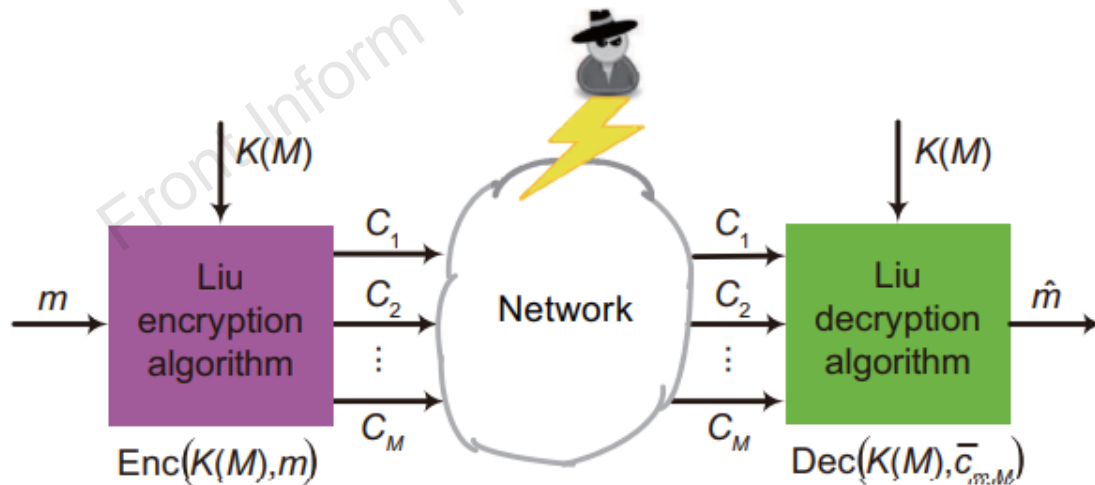

Fig. 2 Block diagram of the Liu cryptosystem

Main idea

- An improved Liu cryptosystem is proposed via signal amplification. Signal amplification is for reduction of the error between encryption and decryption. An amplification operation is performed on plaintext before the encryption process in this research, increasing its proportion in the ciphertext. According to the decryption algorithm, the decrypted plaintext contains two parts, namely, the original plaintext and a random component. The amplification of the plaintext results in a reduction in the proportion of the random component. As a result, the impact of the error between encryption and decryption on the plaintext is alleviated, allowing for satisfactory recovery of the plaintext information.

Main idea

- A reinforcement learning (RL) based privacy-preserving consensus tracking control strategy is proposed for nonstrict-feedback discrete-time multi-agent systems (MASs). With the improved privacy-preserving mechanism, an RL technology is introduced. Different from RL methods, the strategy safeguards sensitive information to ensure the privacy of agents' interaction. For error signals generated by the improved privacy-preserving mechanism, our RL strategy treats them as unknown terms and compensates them on line. This strategy not only provides effective solutions for protecting sensitive information but also improves consensus performance for an MAS.

Method

1. Improved Liu cryptosystem

The improved Liu cryptosystem increases the magnitude of plaintext and reduces the magnitude of random terms in ciphertext calculation, and the action alleviates the impact of random terms on the error between m and \hat{m} , resulting in a better reproducibility of m with privacy protection.

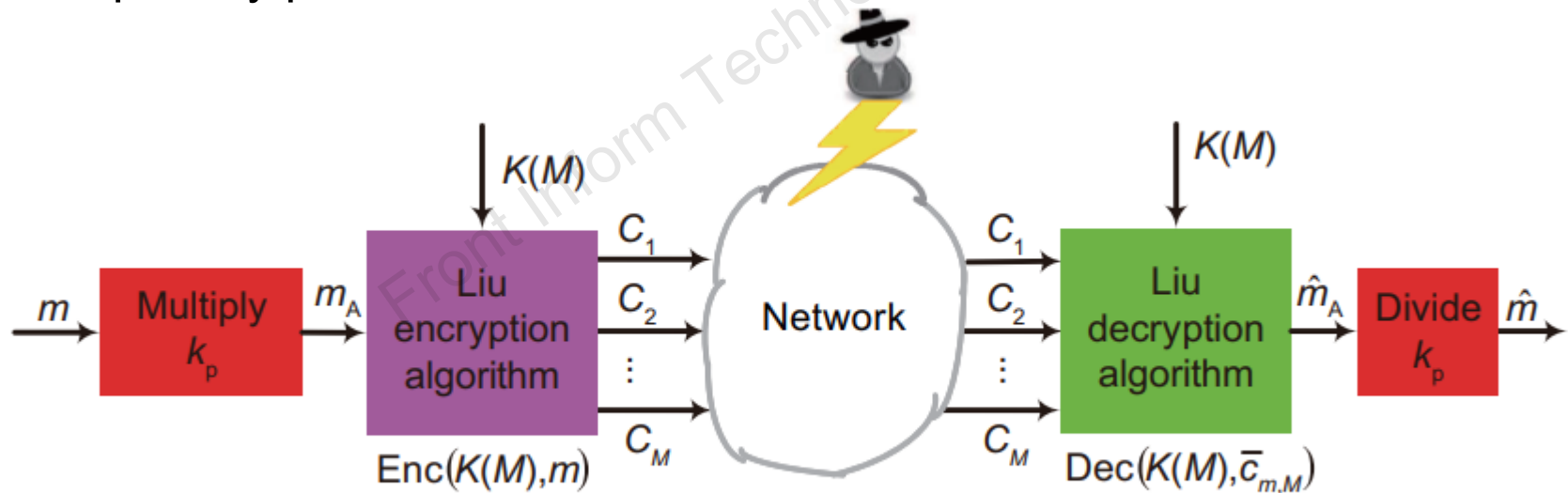

Fig. 3 Block diagram of the improved Liu cryptosystem

Method

2. RL-based privacy-preserving consensus tracking control strategy

The control strategy based on the existing RL method uses real information, while our strategy employs decrypted information for privacy preservation. In the MAS, the encryption and decryption processes are for transmission information, critic neural networks (NNs) use synchronization errors as a reward and punishment for a utility function, and actor NNs use approximation of a utility function for u_i recursively.

Method

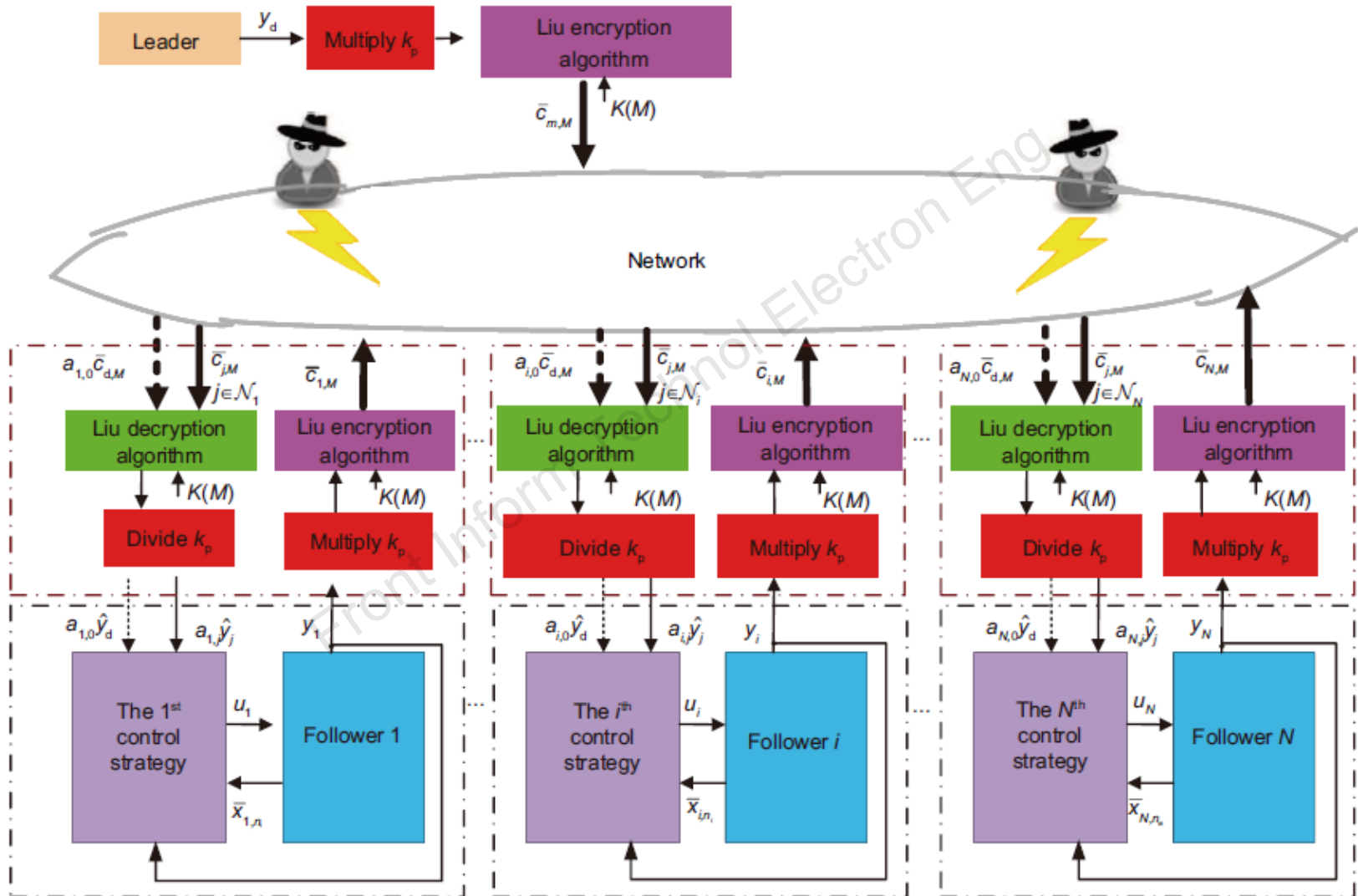

Fig. 4 Block diagram of the multi-agent system (MAS)

Major Results

1. Block diagram and simulation results

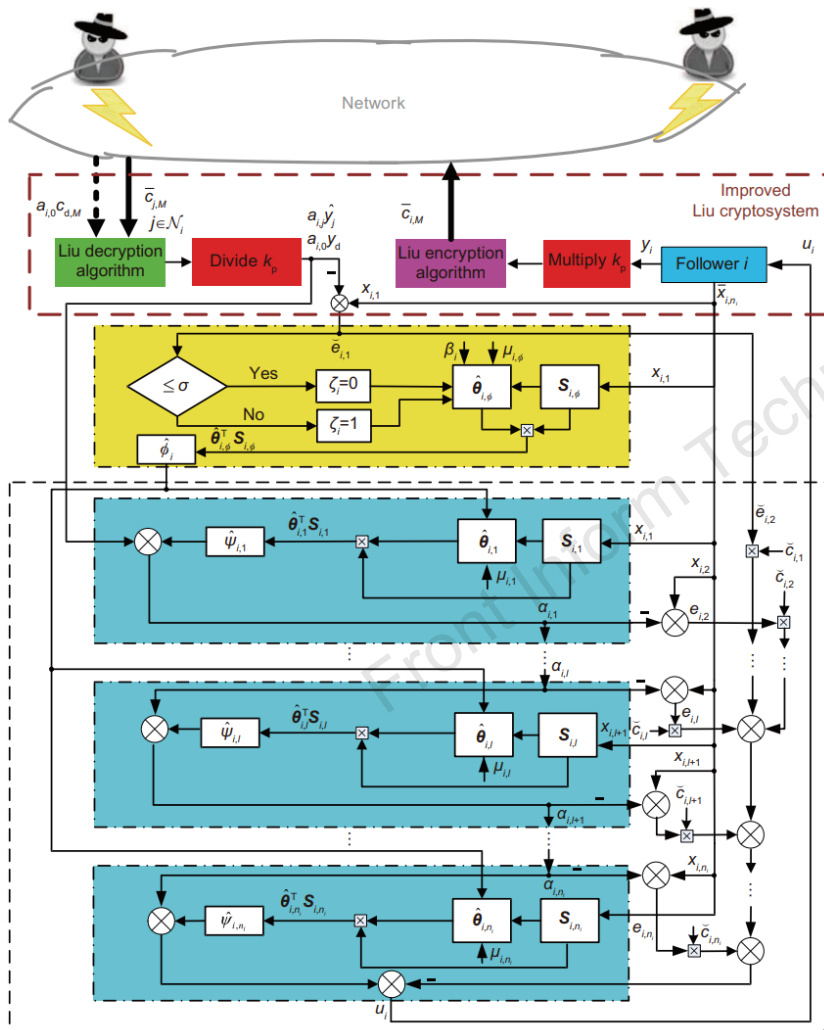

Fig. 5 Block diagram of the i^{th} follower

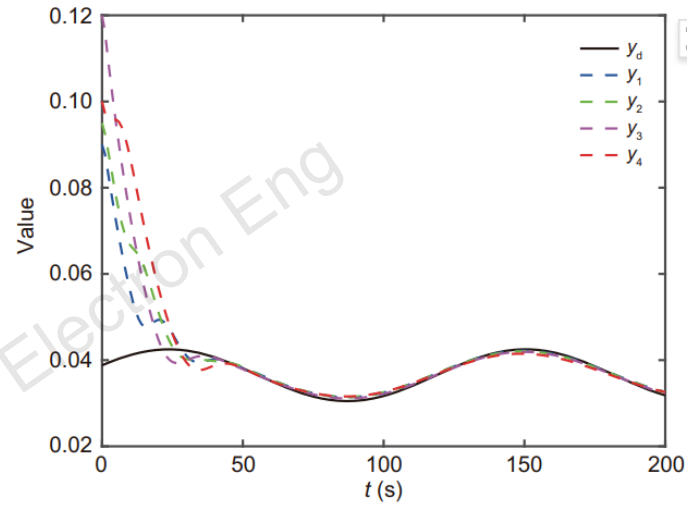

Fig. 7 y_i ($i = 1, 2, 3, 4$) and y_d in Example 1

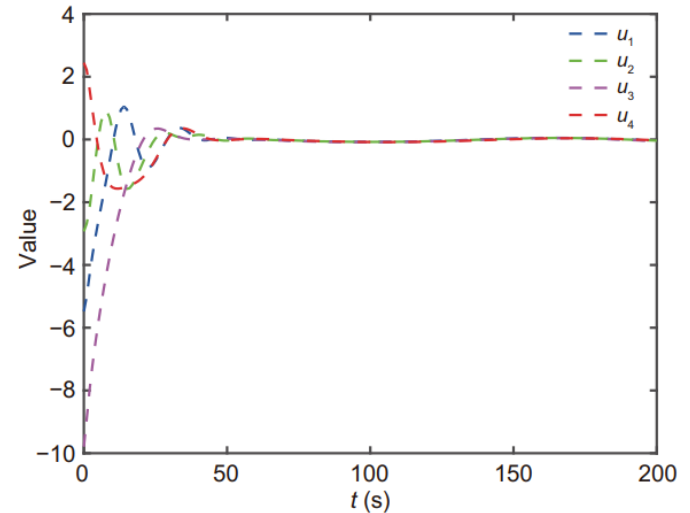

Fig. 8 Control inputs in Example 1

Major Results

2. Relevant information and ciphertext

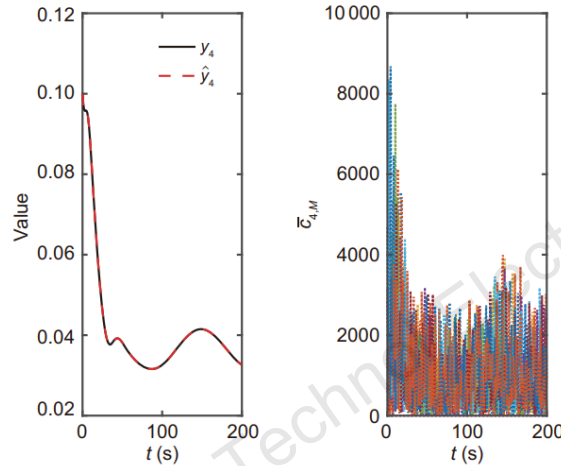

Fig. 9 Relevant information and ciphertext of follower 4 in Example 1

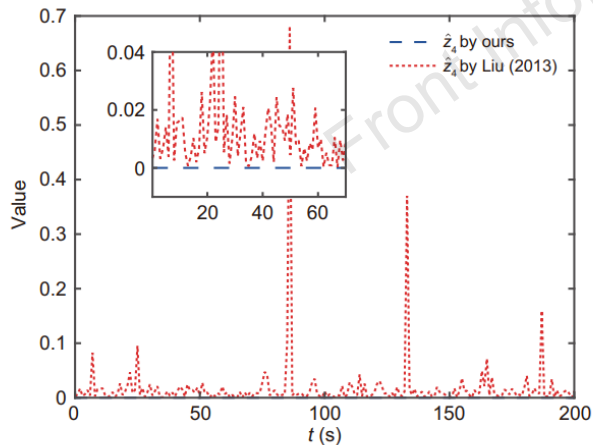

Fig. 10 Comparison of follower 4's decryption errors with different methods in Example 1

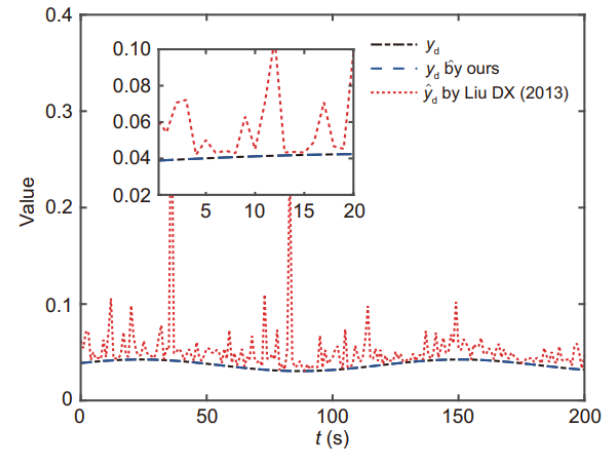

Fig. 11 Comparison of decryption signals of the leader with different methods in Example 1

Major Results

3. Simulation of marine surface vessels

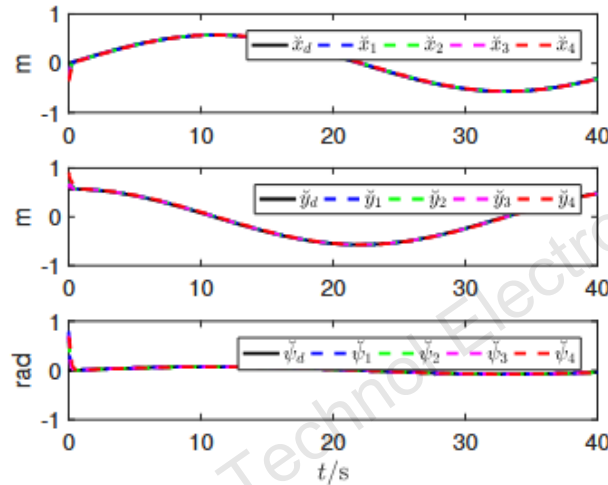

Fig. S1 Output consensus tracking performance of \ddot{x}_i , \ddot{y}_i and $\ddot{\psi}_i$ in Example 2.

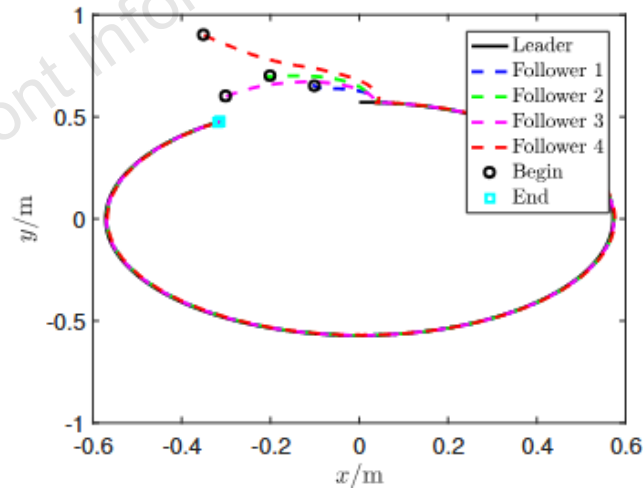

Fig. S2 2-D output consensus tracking in Example 2.

Conclusions

1. An RL-based privacy-preserving consensus tracking control strategy with improved Liu cryptosystem has been proposed for a nonstrict-feedback discrete-time MAS.
2. We observed that the improved Liu cryptosystem encrypts the information transmitted among agents and thus effectively prevents the possibility of intrusion of external information.
3. With the help of a Lyapunov function, the proposed control strategy has guaranteed that all signals are ultimately bounded and that the output consensus errors of the MAS converge to a neighborhood around the origin.



Yang YANG (Senior Member, IEEE) received the B.E., M.E., and Ph.D. degrees in automatic control from Dalian Maritime University, Dalian, China, in 2008, 2010, and 2013, respectively. He is currently a professor with the College of Automation & College of Artificial Intelligence, Nanjing University of Posts and Telecommunications (NJUPT), Nanjing, China. From 2018 to 2019, he held a Visiting Research Fellow Position with the School of Electrical Engineering and Computer Science, Queensland University of Technology, Brisbane QLD, Australia. His research interests include nonlinear control theory and intelligent control. Dr. YANG was a recipient of the National Scholarship for Ph.D. candidates, the HOSCO Special Award, Jiangsu Government Scholarship for Overseas Studies, the Excellent Postdoctoral Research Fellow Award of NJUPT, and the 1311 Talent Project at NJUPT. He serves as a reviewer for various peer-reviewed journals.



Dong YUE (Fellow, IEEE) is currently a professor and the dean of the Institute of Advanced Technology, Nanjing University of Posts and Telecommunications, Nanjing, China, and a Changjiang Professor with the Department of Control Science and Engineering, Huazhong University of Science and Technology, Wuhan, China. Up until now, he has published more than 100 articles in journals and conferences. His research interests include analysis and synthesis of network control systems, multiagent systems, optimal control of power systems, and Internet of Things.