

Jiabao GAO, Xiaoming CHEN, Geoffrey Ye LI, 2024. Deep unfolding based channel estimation for wideband terahertz near-field massive MIMO systems. *Frontiers of Information Technology & Electronic Engineering*, 24(8):1162-1172. <https://doi.org/10.1631/FITEE.2300760>

Deep unfolding based channel estimation for wideband terahertz near-field massive MIMO systems

Key words: Terahertz; Massive MIMO; Channel estimation; Deep learning

Corresponding author: Xiaoming CHEN

E-mail: chen_xiaoming@zju.edu.cn

 ORCID: <https://orcid.org/0000-0002-1818-2135>

Motivations

- In terahertz massive MIMO channel estimation, the near-field beam split effect caused by large bandwidth and array aperture will decrease the channel sparsity and destroy the channel sparsity structure in the angular–frequency domain.
- Existing compressive sensing algorithms suffer from either bad performance or high complexity. A good tradeoff is desired.
- Current deep learning approaches are trained separately under different system configurations, which increases the training and storage overhead and decreases the robustness.

Main ideas

- By using frequency-dependent polar dictionaries, the near-field beam split effect can be properly handled.
- An advanced approximate message passing - sparse Bayesian learning (AMP-SBL) unfolding algorithm is proposed for channel estimation. Specifically, the M-step in each iteration of AMP-SBL is replaced by a deep neural network (DNN), which improves the estimation performance and convergence speed by training a lot of data.
- Under the joint effort of the proposed configuration-related attention mechanism and weighted normalized mean-squared error (NMSE) loss function, effective mixed training is realized to obtain a single universal DNN.

Methods

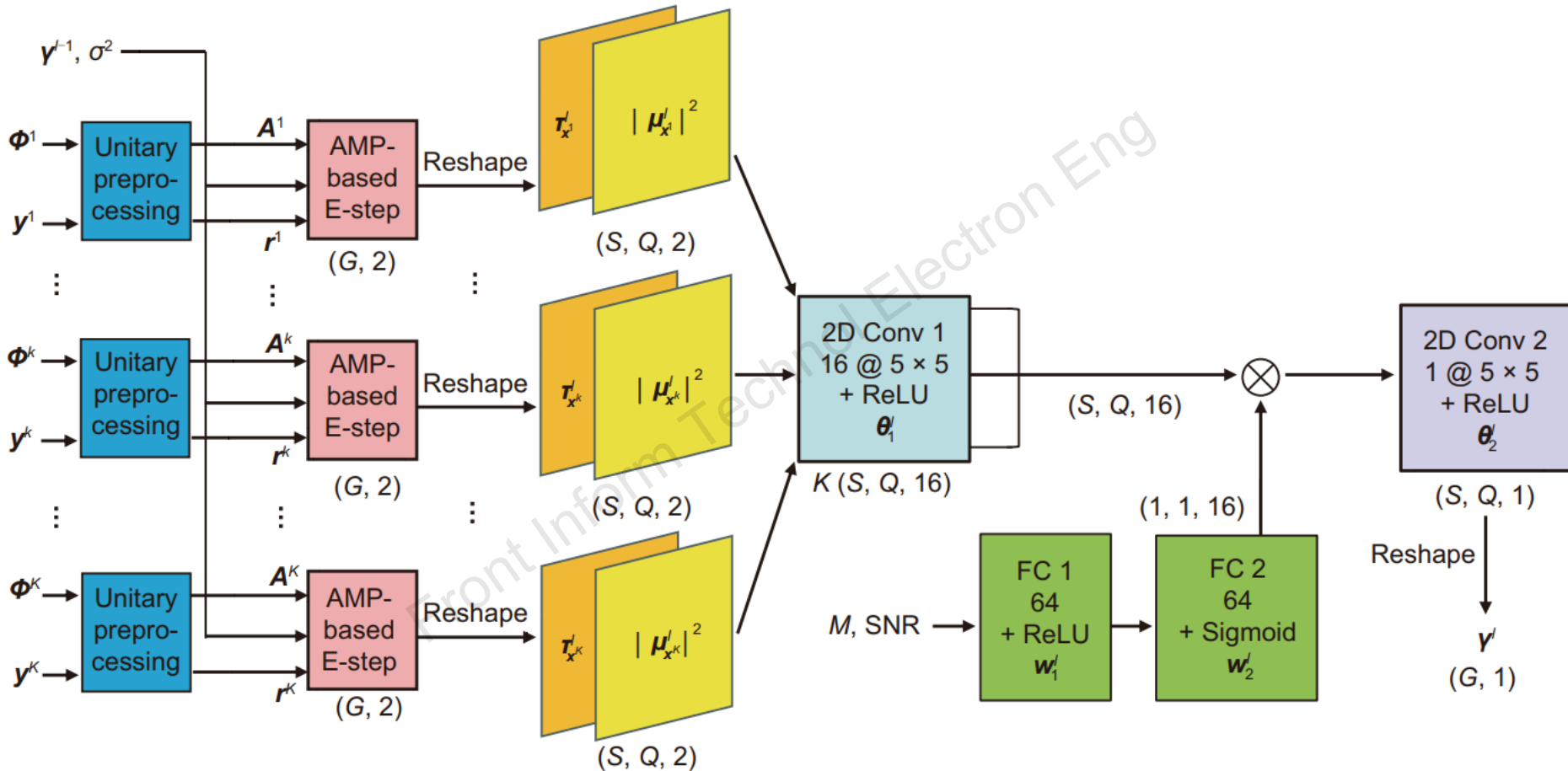

Architecture of the l^{th} approximate message passing - sparse Bayesian learning layer

Major results

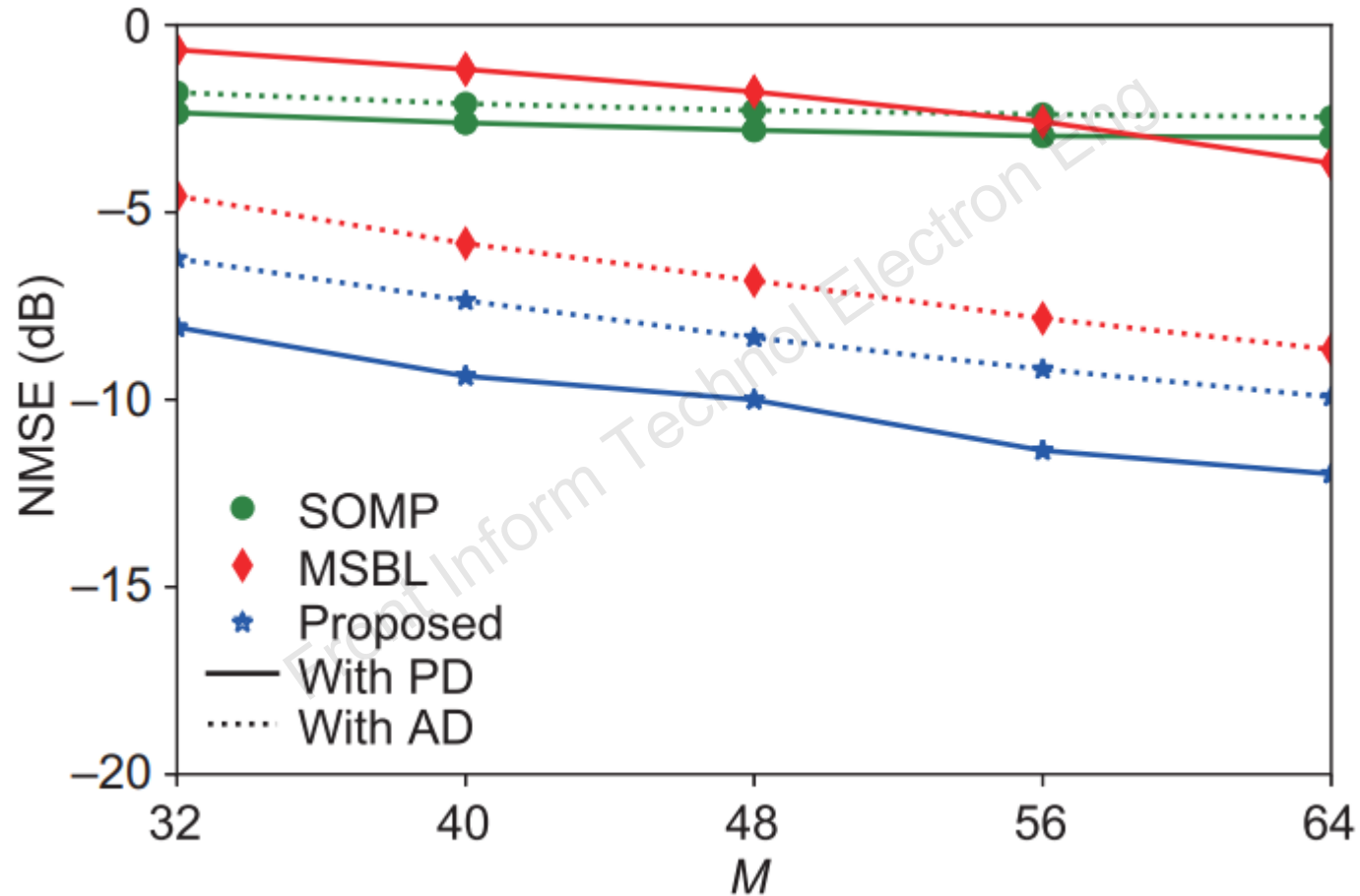

The proposed approach outperforms baselines under various configurations.

Conclusions

To realize robust high-performance low-complexity terahertz massive MIMO channel estimation, we

- alleviate the near-field beam split effect by using frequency-dependent polar dictionaries,
- improve the performance and convergence speed by deeply unfolding the AMP-SBL algorithm, and
- realize effective mixed training through configuration-related loss function and network architecture design.

Simulation results verified the superiority of the proposed approach.



Jiabao GAO received the BS degree in information engineering from Zhejiang University, Hangzhou, China, in 2019, and the PhD degree at the Zhejiang Provincial Key Laboratory of Information Processing, Communication and Networking, Zhejiang University, Hangzhou, China, in 2024. He was a Visiting Scholar with the Department of Electrical and Electronic Engineering, Imperial College London, UK, from September 2021 to March 2023. His current research interests include massive MIMO, channel estimation, and machine learning for wireless communications.

Front Inform Technol



Xiaoming CHEN received the BS degree from Hohai University in 2005, the MS degree from Nanjing University of Science and Technology in 2007 and the PhD degree from Zhejiang University in 2011, all in electronic engineering. He is currently a Professor with the College of Information Science and Electronic Engineering, Zhejiang University, Hangzhou, China. From March 2011 to October 2016, he was with Nanjing University of Aeronautics and Astronautics, Nanjing, China. From February 2015 to June 2016, he was a Humboldt Research Fellow at the Institute for Digital Communications, Friedrich-Alexander-University Erlangen-Nürnberg (FAU), Germany. He served as an Editor for *IEEE Trans Commun* and *IEEE Commun Lett*, and a Guest Editor for *IEEE J Sel Areas Commun* (Massive Access for 5G and Beyond) and *IEEE Wirel Commun* (Massive Machine-Type Communications for IoT). He received the Best Paper Awards at the IEEE Global Communications Conference (GLOBECOM) 2020, the International Conference on Wireless Communications and Signal Processing (WCSP) 2020, the IEEE International Conference on Communications (ICC) 2019, and the IEEE/CIC International Conference on Communications in China (ICCC) 2018. His research interests focus mainly on LEO satellite constellation, Internet of Things, and smart communications.



Geoffrey Ye Li (Fellow, IEEE) is currently a Chair Professor with Imperial College London, U.K. Before joining Imperial College London in 2020, he was a Professor with the Georgia Institute of Technology, USA, for 20 years and a Principal Technical Staff Member with AT&T Labs—Research (previously, Bell Labs), Murray Hill, NJ, USA, for five years. He made fundamental contributions to orthogonal frequency-division multiplexing for wireless communications, established a framework on resource cooperation in wireless networks, and introduced deep learning to communications. In these areas, he has published over 600 journal and conference papers, and has been granted over 40 patents. His publications have been cited over 65 000 times with an H -index of 116. He has been listed as a Highly Cited Researcher by Clarivate/Web of Science almost every year. He won the 2024 IEEE Eric E. Sumner Award and several awards from IEEE Signal Processing, Vehicular Technology, and Communications Societies, including the 2019 IEEE ComSoc Edwin Howard Armstrong Achievement Award. He was elected to be IEEE Fellow and IET Fellow for his contributions to signal processing for wireless communications.