

Amjed ALI, Noor Muhammad KHAN, 2025. Space–time processing for inflight broadband connectivity: critical analysis, challenges, and future directions. *Frontiers of Information Technology & Electronic Engineering*, 26(11):2081-2113. <https://doi.org/10.1631/FITEE.2400117>

# Space–time processing for inflight broadband connectivity: critical analysis, challenges, and future directions

**Key words:** Airborne Internet access; Inflight broadband connectivity; Multiple-input multiple-output (MIMO); Precoding; Beamforming; Direct air-to-ground communication (DA2GC); Space–time processing

Corresponding author: Amjed ALI

E-mail: [dee193003@cust.pk](mailto:dee193003@cust.pk)

 ORCID: <https://orcid.org/0009-0006-5305-9278>

# Space–time processing (STP)

- ❑ STP is used in wireless communication systems to improve channel performance and reliability.
- ❑ It involves processing the signals transmitted and received by multiple antennas to take advantage of the spatial and temporal diversity of the wireless channel.
- ❑ STP takes advantage of the capability of a multi-antenna system to simultaneously transmit and receive multiple (independent) data streams.

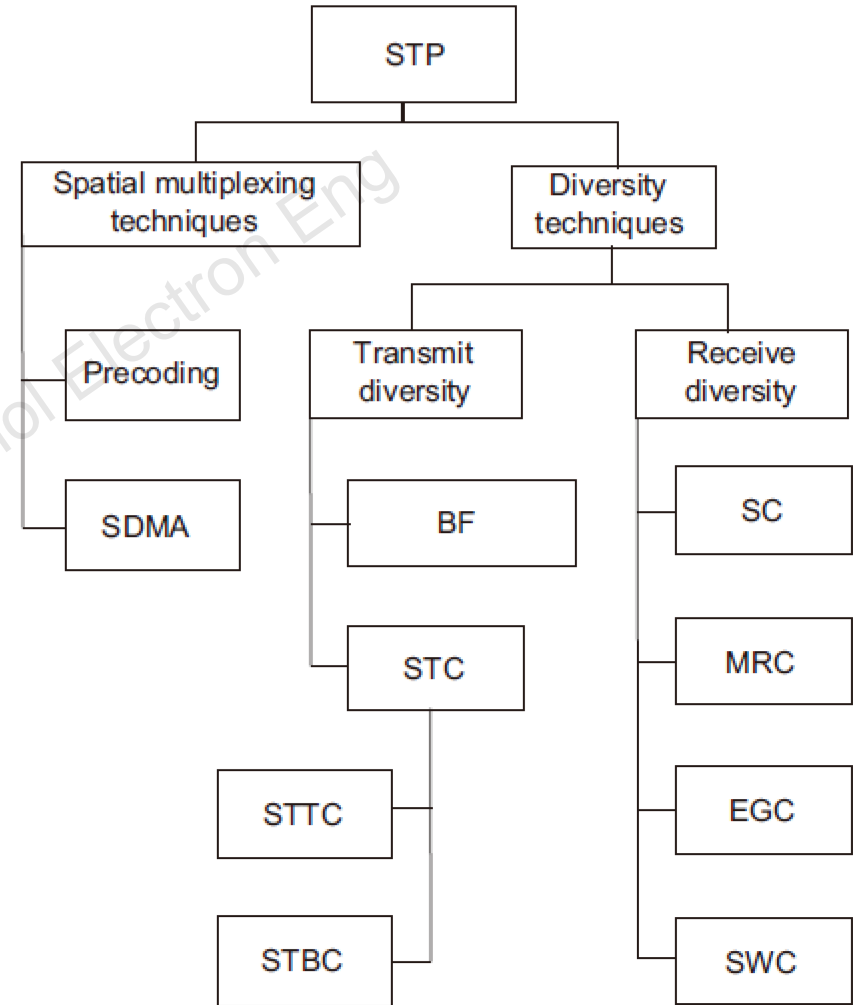

Fig. 4 Categories of STP techniques

# Spatial multiplexing techniques

---

- ❑ Spatial multiplexing increases the data rate by exploiting the spatial properties of the wireless channel without requiring more bandwidth or power.
- ❑ Using multiple antennas at the transmitter and receiver enables the simultaneous transmission of multiple data streams over the same frequency channel.
- ❑ Each antenna transmits data simultaneously, and the receiver then combines the signals coming from several antennas to recover the original data streams.
- ❑ Spatial multiplexing techniques can be further classified as precoding and space division multiple access (SDMA).
- ❑ In multiple-input multiple-output (MIMO) communication systems, these techniques can be employed individually or in combination to improve data throughput.

# Diversity techniques

---

- ❑ Diversity approaches are used to reduce the loss in error performance (the aim is to steepen the bit error rate (BER) vs. signal-to-noise ratio (SNR) curve) caused by unstable wireless fading channels, such as those vulnerable to multipath fading.
- ❑ The idea behind diversity in data transmission is that severe fading is relatively unlikely to occur simultaneously across multiple statistically independent fading channels.
- ❑ There are several strategies to achieve diversity gain, which are
  - space diversity,
  - polarization diversity,
  - frequency diversity,
  - time diversity, and
  - angle diversity.

# Space–time wireless communication systems

- A typical space–time wireless communication system is made up of  $N_T$  transmit antennas and  $N_R$  receive antennas.
- STP system (commonly referred to as MIMO) can increase the throughput by a factor of  $\min(N_T, N_R)$  in comparison to a traditional single antenna system without using more spectral bandwidth or transmit power.

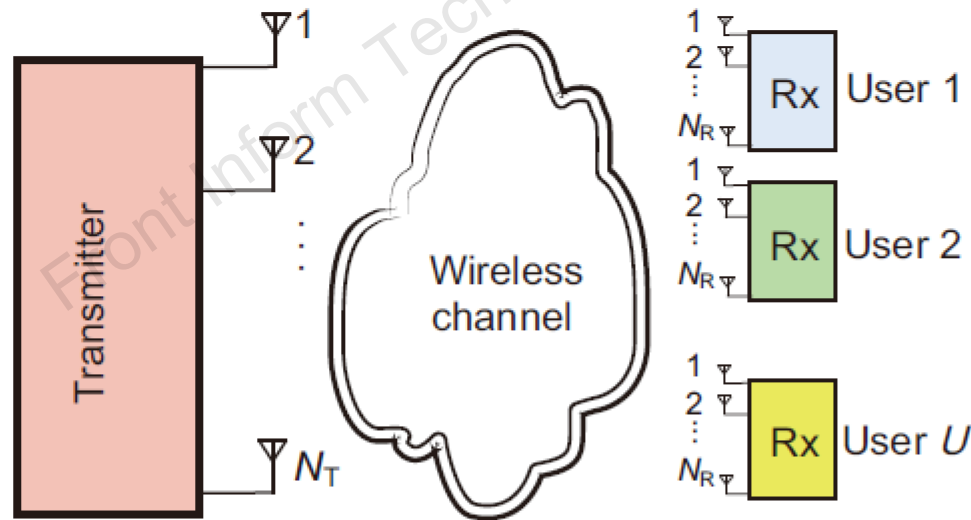

Fig. 5 Space–time wireless communication system

# Precoding techniques

- ❑ To increase the capacity of a MIMO channel and enable it to communicate simultaneously with several users or applications, precoding is used.
- ❑ Precoding is a spatial multiplexing technique employed in MIMO systems to lessen or eliminate the effects of fading and interference, while boosting throughput.
- ❑ The throughput and gains that can be achieved are determined by the associated precoding technique.

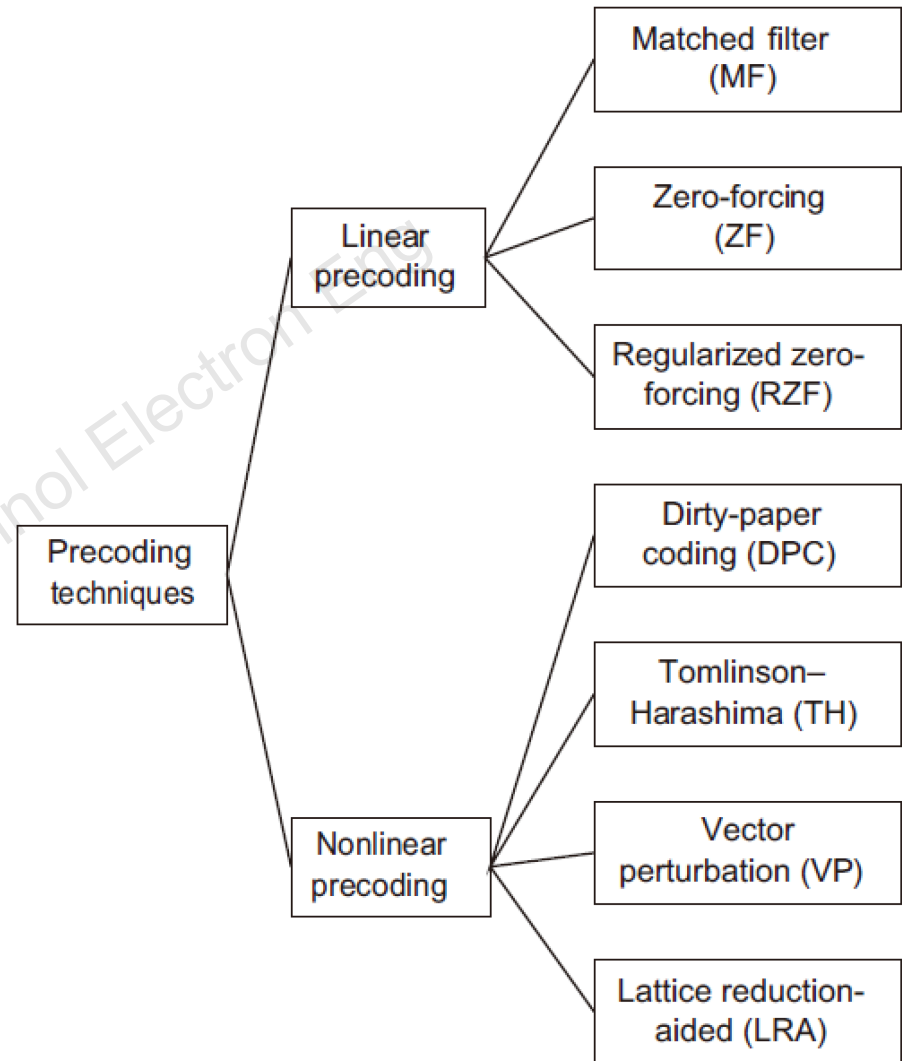

Fig. 8 Classification of precoding techniques

# Beamforming (BF) techniques

- ❑ BF is an STP (transmit diversity) technique to improve signal quality and system reliability.
- ❑ In BF, the antenna array transmits or receives radio frequency (RF) signals directionally by modifying its phase and amplitude at each antenna element.
- ❑ Some researchers categorized BF techniques based on their physical properties such as switched and adaptive BF.
- ❑ Other classification is based on signal processing, including analog, digital, and hybrid (analog and digital combined) BF techniques.

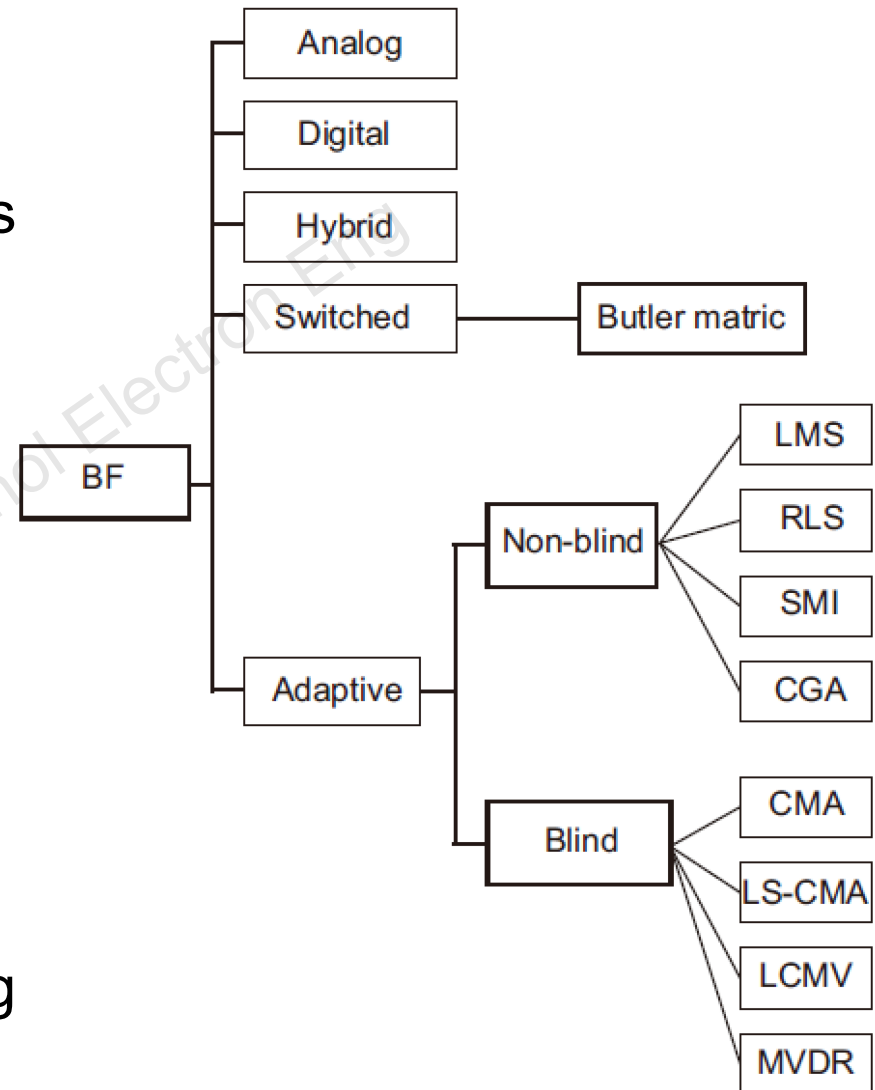

Fig. 12 Classification of BF techniques

# Future directions

---

- ❑ Although using STP in airborne networks has many advantages, there are still several challenges that need to be addressed, such as hardware constraints, energy efficiency, pilot contamination, efficient precoding, channel estimation, user scheduling, and signal detection.
- ❑ Another exciting area of research is the use of machine learning and deep learning techniques to predict statistical channel characteristics.
- ❑ Owing to the dynamic nature of airborne networks, another untouched avenue for future research involves designing antennas for enabling inflight connectivity (IFC) leveraging STP techniques in conjunction with the millimeter wave (mmWave) frequency spectrum.

# Conclusions

---

This work was concentrated on the application of STP techniques in airborne networks to enable IFC. We aimed to develop a comprehensive understanding of the underlying concepts and theoretical principles behind STP techniques in airborne networks for enabling IFC. We first conducted a thorough literature review. Then, we presented a performance analysis that assessed the use of various STP techniques in airborne networks. Finally, we suggested potential areas for future research, such as exploring advanced communication techniques and technologies, aircraft mobility and attention modeling, channel estimation, Doppler effect, efficient precoding techniques, effect of aircraft antennas on connectivity, and beam steering.