

Zhichao CHENG, Shupeí ZHANG, Shu FU, Boya DI, 2024. Hybrid near- and far-field three-stage beam training with beam split for RIS-assisted OFDM communications. *Frontiers of Information Technology & Electronic Engineering*, 25(12):1664-1678. <https://doi.org/10.1631/FITEE.2400372>

# Hybrid near- and far-field three-stage beam training with beam split for RIS-assisted OFDM communications

**Key words:** Near–far field; Beam split; Codebook design; Beam training; Reconfigurable intelligent surfaces

Corresponding author: Boya DI

E-mail: [diboya@pku.edu.cn](mailto:diboya@pku.edu.cn)

 ORCID: <https://orcid.org/0000-0003-3484-1361>

# Background

1. With the development of millimeter-wave (mmWave) communication systems, large-scale reconfigurable intelligent surfaces (**RISs**) have gained considerable attention as a promising technology for signal strength enhancement and coverage extension.
2. To mitigate the high overhead of obtaining accurate channel state information (CSI), **codebook design** and **beam training** are widely employed to offer efficient transmission schemes even in the absence of precise channel information.

# Motivation

In RIS-assisted OFDM communication systems, new challenges have arisen due to large antenna arrays and large bandwidths:

1. As the scale of the antenna increases and the operating frequency rises, the boundary between the near and far fields, e.g., the Rayleigh distance in classical electromagnetic (EM) theory, also expands. Such **near field expansion** leads to degraded performance of far-field codebooks based on the planar wave model.
2. The widening band exacerbates the **beam split phenomenon** in both the near and far fields, resulting in significant disparities in the beam directions across different subcarriers in orthogonal frequency division multiplexing (OFDM) systems.

# Main contributions

1. We analyze the beam split effect in RIS-assisted OFDM communication systems. Using such an effect, we propose a **beam-split-aware codebook** with fewer codewords compared with existing narrow-band codebooks.
2. Based on the proposed beam-split-aware codebook, we propose a **three-stage beam training mechanism** to obtain the optimal codeword with low time overhead.
3. Simulation results demonstrate the effectiveness of the proposed codebook design and beam training mechanism. Compared with existing near-field and far-field codebook-based beam training schemes, our proposed scheme performs better in terms of both beam training resolution and sum rate in the hybrid near–far field.

# Framework

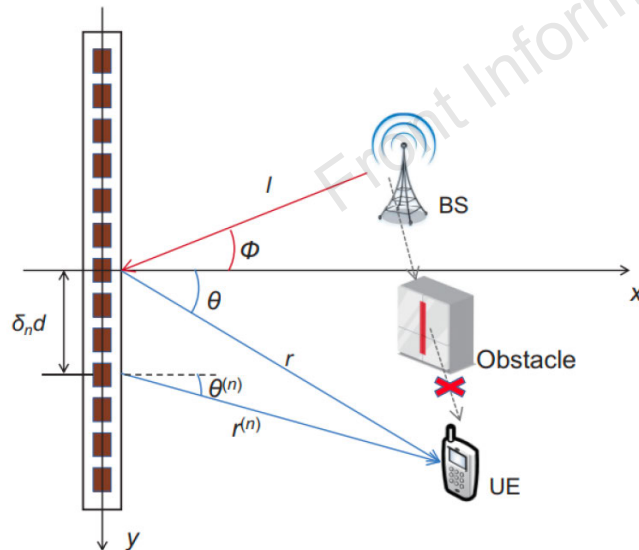
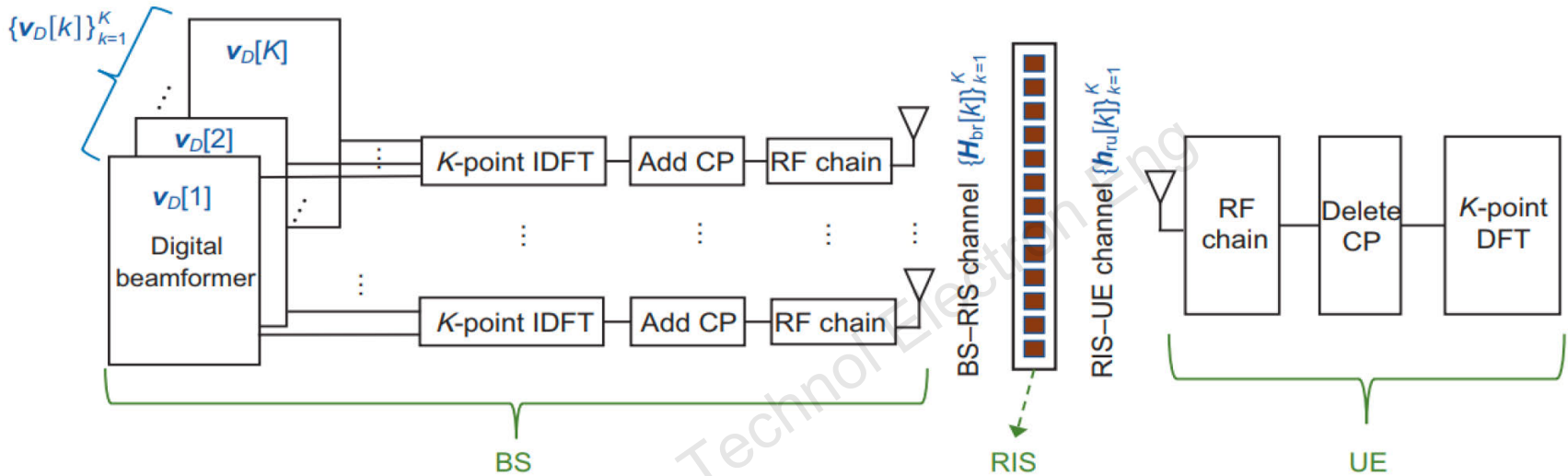

Schematic of the transmission model in the RIS-assisted communication system (BS: base station; CP: cyclic prefix; DFT: discrete Fourier transform; IDFT: inverse DFT; RF: radio frequency; UE: user equipment)

# Method

1. We first analyze the beam split effect of RIS-assisted OFDM communication systems in the near–far field.

$$\psi_k = \frac{f_c}{f_k}(\psi^{(c)} + \psi_{\text{bs}}) - \psi_{\text{bs}} = \frac{f_c}{f_k}\psi^{(c)} - \frac{f_k - f_c}{f_k}\psi_{\text{bs}}, \quad (10)$$

$$\mu_k = \frac{f_c}{f_k}(\mu^{(c)} + \mu_{\text{bs}}) - \mu_{\text{bs}} = \frac{f_c}{f_k}\mu^{(c)} - \frac{f_k - f_c}{f_k}\mu_{\text{bs}}. \quad (11)$$

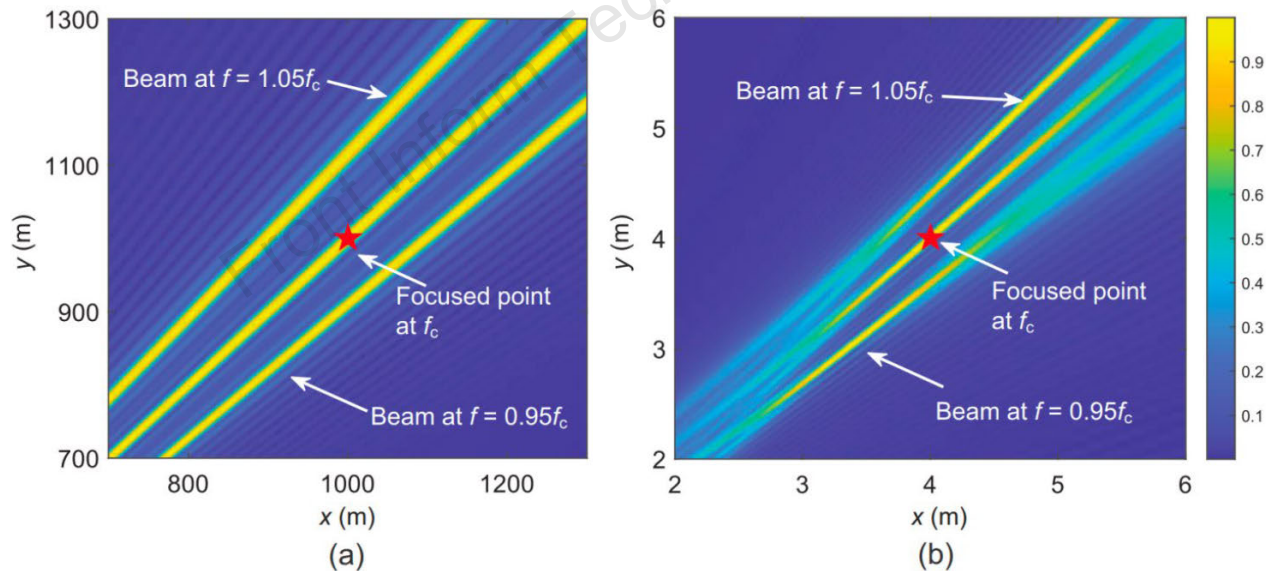

Beam split in the far field (a) and near field (b)

# Method

2. We then design a beam-split-aware codebook capable of effectively covering the near–far field. We decompose the codebook design into angular sampling and distance sampling. After acquiring the position of sampling points, codewords are finally designed.

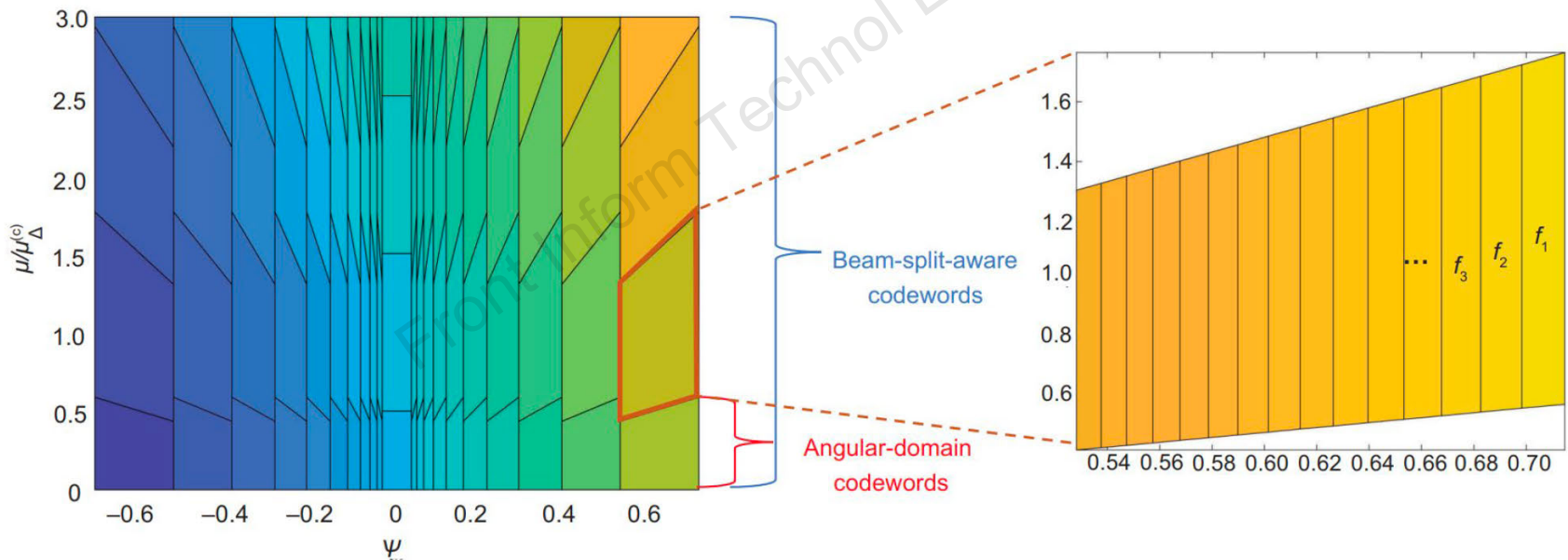

Coverage range of beam-split-aware codewords

# Method

3. Finally, a three-stage beam training mechanism characterized by low training overhead is presented which can be extended to multi-user scenarios.

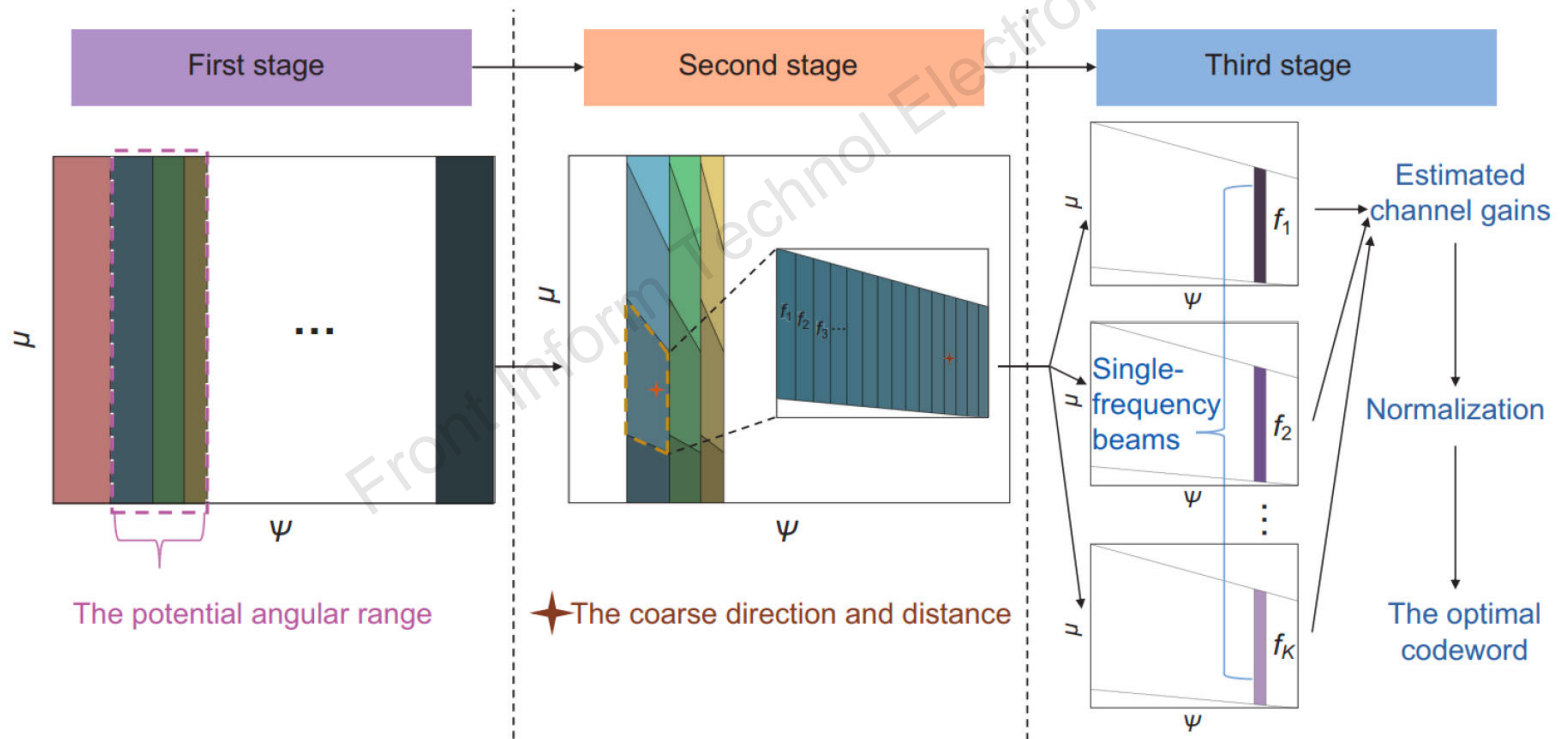
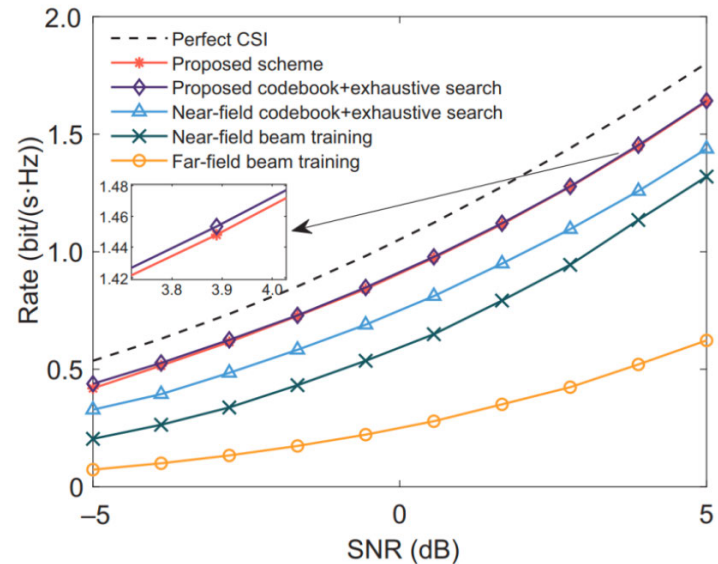
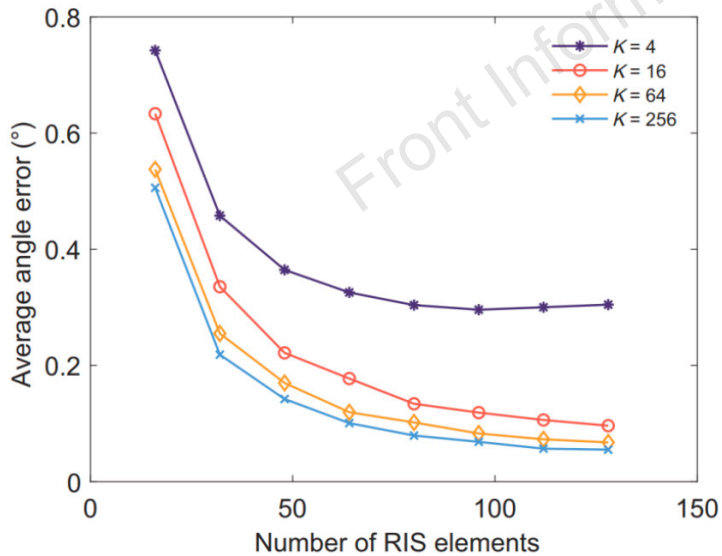
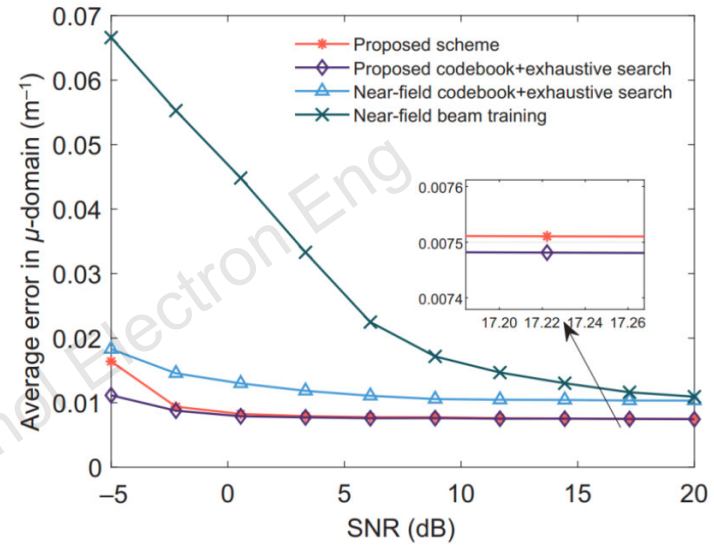
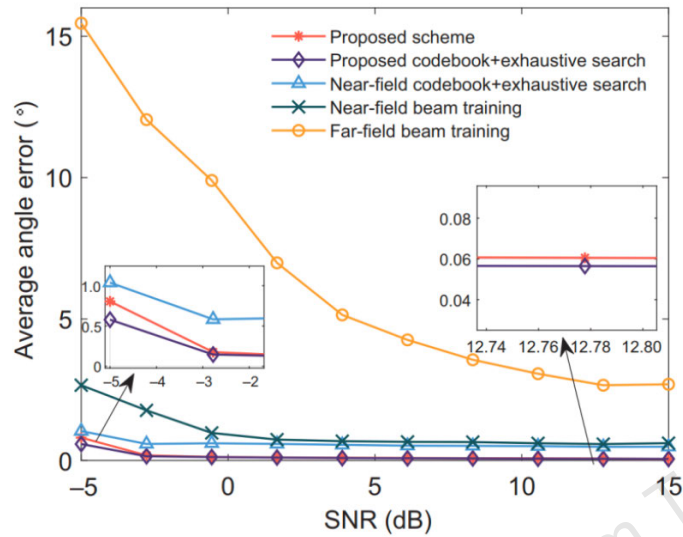

Illustration of the proposed three-stage beam training mechanism

# Major results



# Conclusions

1. Considering both near-field and far-field EM propagation characteristics, the proposed scheme is universally applicable to RIS-assisted near–far field wideband systems.
2. Benefiting from staged beam training, the proposed scheme significantly reduces training overhead compared to exhaustive search, while achieving comparable rate performance.
3. By taking into account the beam split effect, the proposed scheme outperforms conventional schemes in terms of the beam training resolution and sum rate.



Zhichao CHENG ([chengzhichao@stu.pku.edu.cn](mailto:chengzhichao@stu.pku.edu.cn)) is currently pursuing the B.S. degree with the School of Electronics Engineering and Computer Science, Peking University. His main research interests include reconfigurable intelligent surfaces, holographic MIMO, and near-field communications.



Shupe ZHANG ([zhangshupe@pku.edu.cn](mailto:zhangshupe@pku.edu.cn)) received the B.S. degree in electronic and information engineering from Peking University, China, in 2023. He is currently pursuing the Ph.D. degree with the School of Electronics, Peking University. His current research interests include reconfigurable intelligent surfaces, holographic MIMO, and near-field communications.



Shu FU ([shufu@cqu.edu.cn](mailto:shufu@cqu.edu.cn)) received the Ph.D. degree in communication and information system from University of Electronic Science and Technology of China, Chengdu, China, in 2016, focusing on cooperative multi-point (CoMP) wireless network, joint scheduling and routing in wavelength division multiplexing (WDM) network, and cross-network energy efficiency. He is currently an Associate Professor with the Department of Microelectronics and Communication Engineering, Chongqing University, Chongqing, China. His research interests include machine learning in B5G, UAV aided wireless networks, and terrestrial-satellite networks.



Boya Di ([diboaya@pku.edu.cn](mailto:diboaya@pku.edu.cn)) received the B.S. degree in electronic engineering from Peking University, China, in 2014, and the Ph.D. degree from the Department of Electronics, Peking University, in 2019. She was a Post-Doctoral Researcher with the Imperial College London. She is currently an Assistant Professor with Peking University. Before joining Peking University, she was an Assistant Professor. She was a recipient of the 2020 IEEE N2WOMEN Top-10 Rising Star in Communications and Networking, the 2021 IEEE ComSoc Asia-Pacific Outstanding Paper Award, the 2022 IEEE ComSoc Asia-Pacific Outstanding Young Researcher Award, and the 2023 IEEE ComSoc TCCN Publication Award. She serves as an Associate Editor for *IEEE Transactions on Vehicular Technology* and an Editor for *IEEE Communications Surveys and Tutorials* and *IEEE Internet of Things Journal*. Her current research interests include metasurface-enabled communications and sensing, edge computing, and aerial access networks.