

Honghui XIANG, Kejun LEI, Kaiqing ZHOU, Wenjing TUO, Hongbin LIU, 2025.  
Spectrum sensing method based on a multi-scale feature fusion network. *Frontiers of Information Technology & Electronic Engineering*, 26(12):2638-2653.

<https://doi.org/10.1631/FITEE.2500297>

# Spectrum sensing method based on a multi-scale feature fusion network

**Key words:** Cognitive radios; Spectrum sensing; Deep learning; Multi-scale feature fusion

Corresponding author: Kejun LEI

E-mail: leikejun-123@163.com

 ORCID: <https://orcid.org/0000-0001-7881-1768>

# Motivation

- Targeting the degraded spectrum sensing performance caused by severe SNR fluctuations, especially the limited feature extraction and inefficient feature utilization of traditional CNNs under low-SNR conditions, a novel spectrum sensing method based on a multi-scale feature fusion network (MSFFNet) is proposed, which effectively captures multi-scale information, suppresses redundant features, and significantly improves detection performance in low-SNR communication scenarios.

# Main idea

- MSFFNet for spectrum sensing: A novel multi-scale feature fusion network that extracts local and global spectrum features in parallel, significantly improving multi-scale signal perception under low-SNR conditions.
- AFSS + MLFFM: An adaptive feature screening and multi-level fusion strategy that emphasizes key features, suppresses redundancy, and enables effective cross-scale feature integration.
- Low-SNR evaluation framework: A multi-level mixed-SNR dataset and a Rayleigh fading channel model are constructed, demonstrating strong accuracy, scalability, and robustness of MSFFNet.

# Method

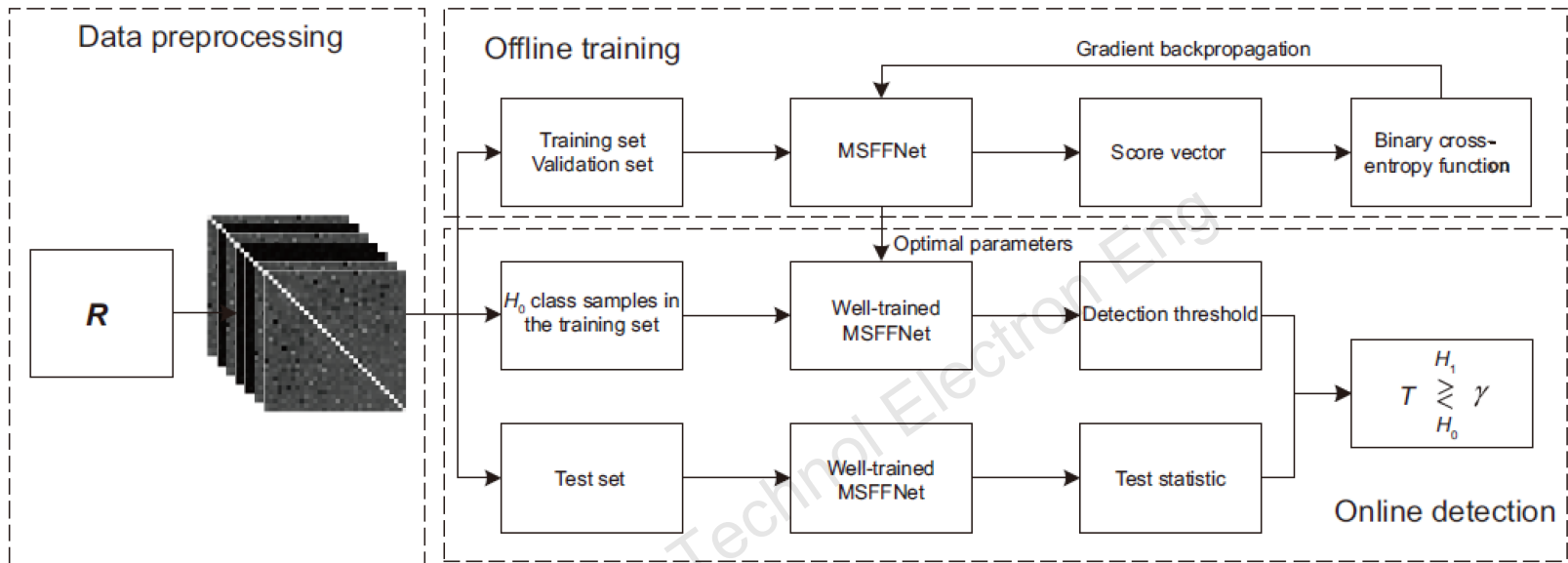

Fig. 1 Spectrum sensing system based on MSFFNet

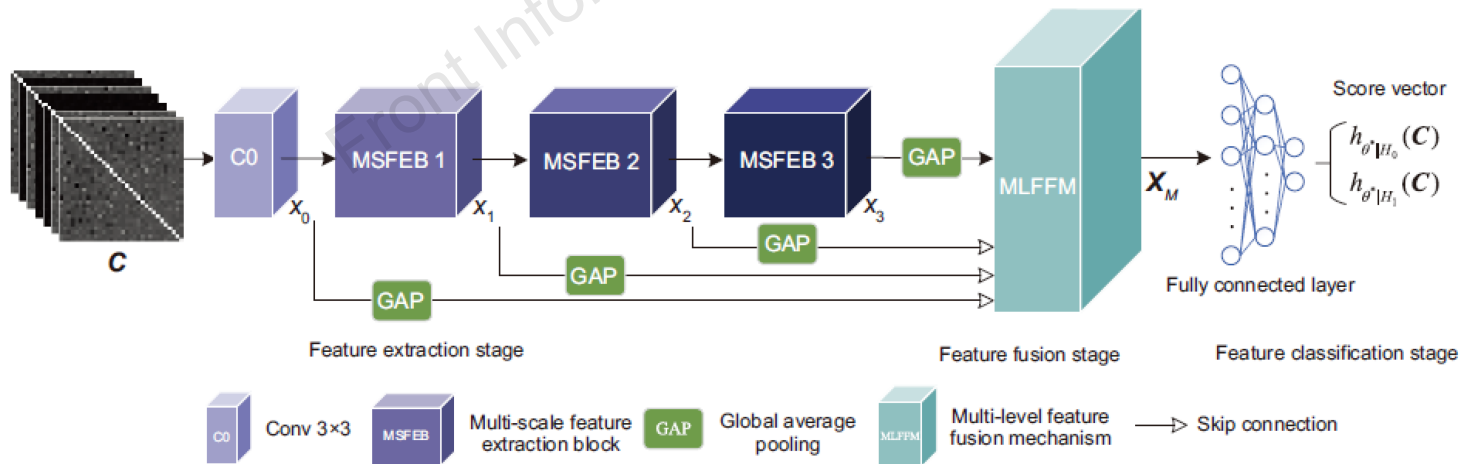
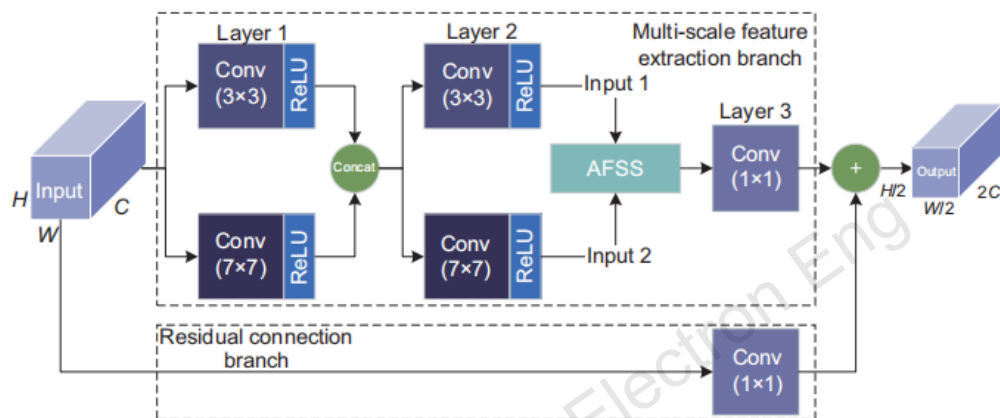
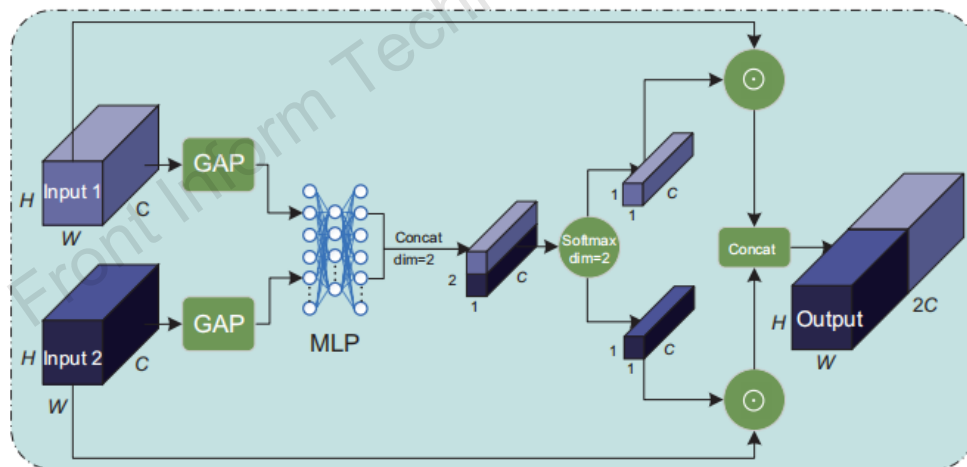

Fig. 3 MSFFNet model structure

# Method



(a)



(b)

Fig. 4 Illustration of the multi-scale feature extraction (a) and AFSS in the MSFEB (b).  $\otimes$ : channel-wise multiplication

# Method

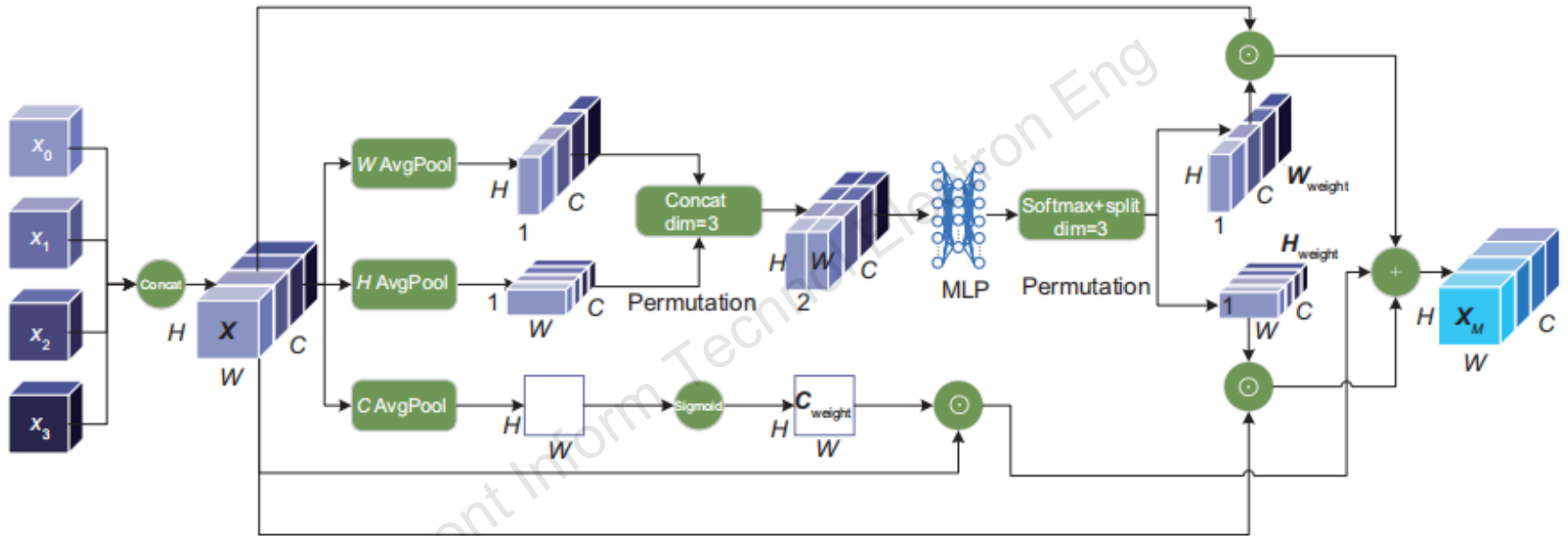

Fig. 5 Illustration of the MLFFM

# Results

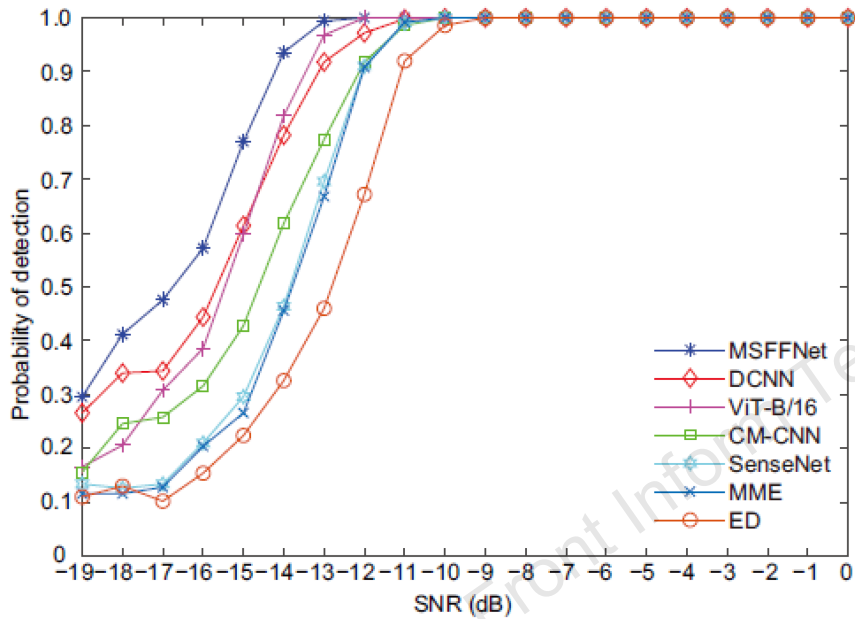

Fig. 7  $P_d$ -SNR curves of the MSFFNet and six comparison methods

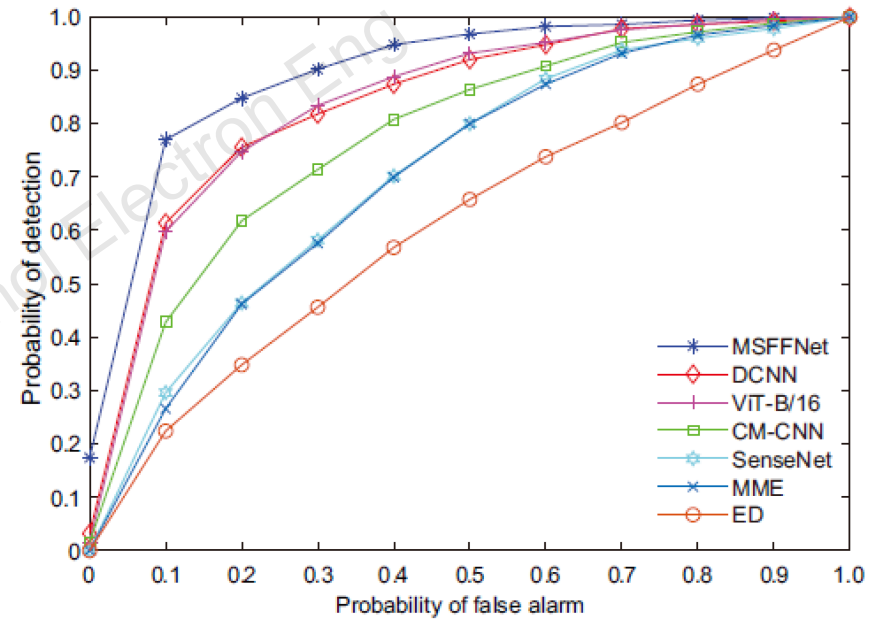

Fig. 8 ROC curves of the MSFFNet and six comparison methods

# Results

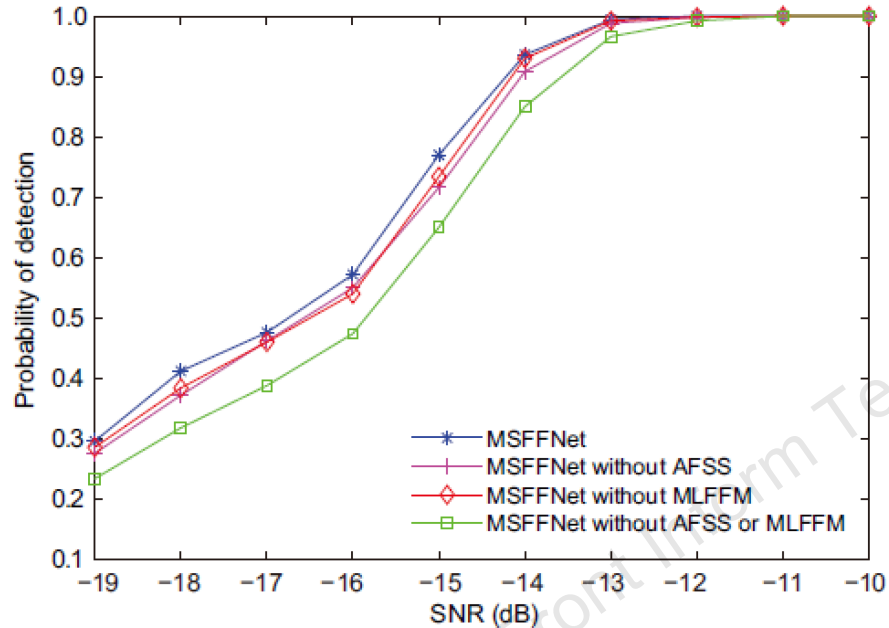

Fig. 9 Ablation simulation of the MSFFNet

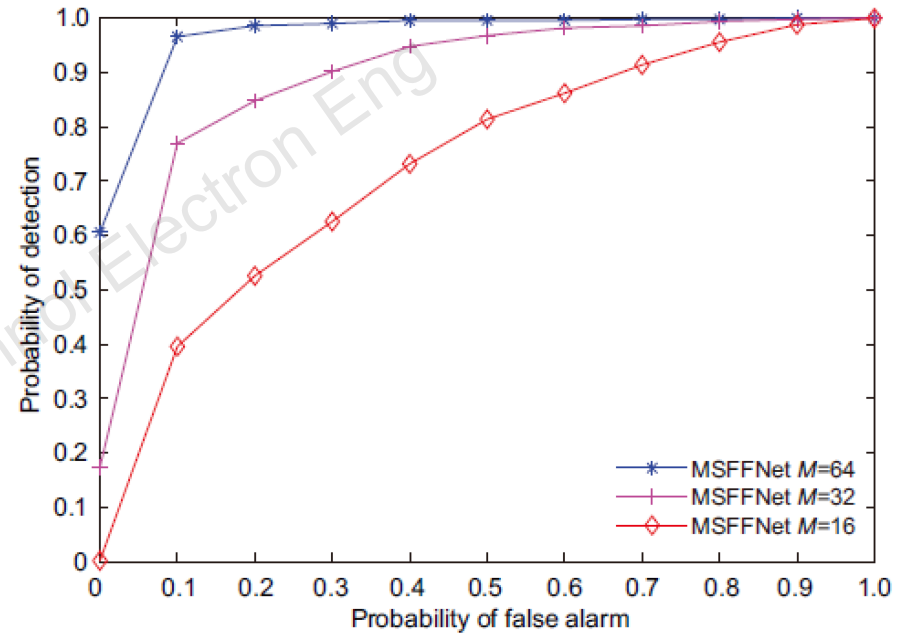

Fig. 10 ROC curves of the MSFFNet with different numbers of antennas

# Results

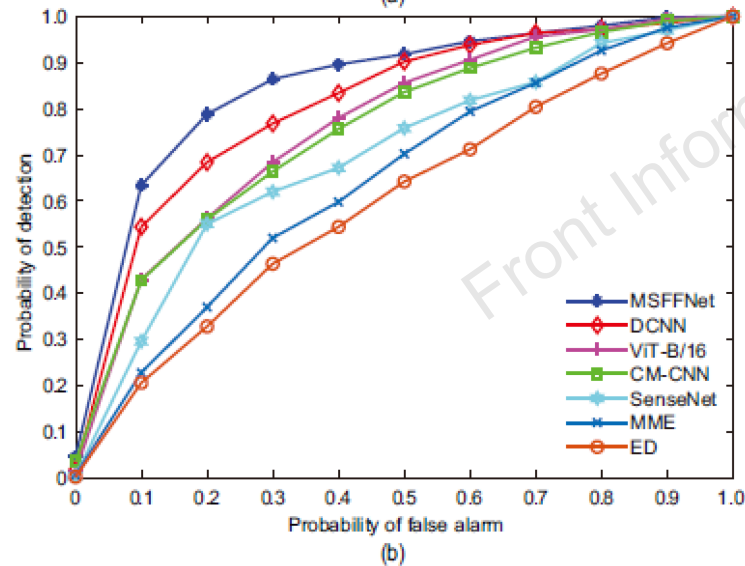
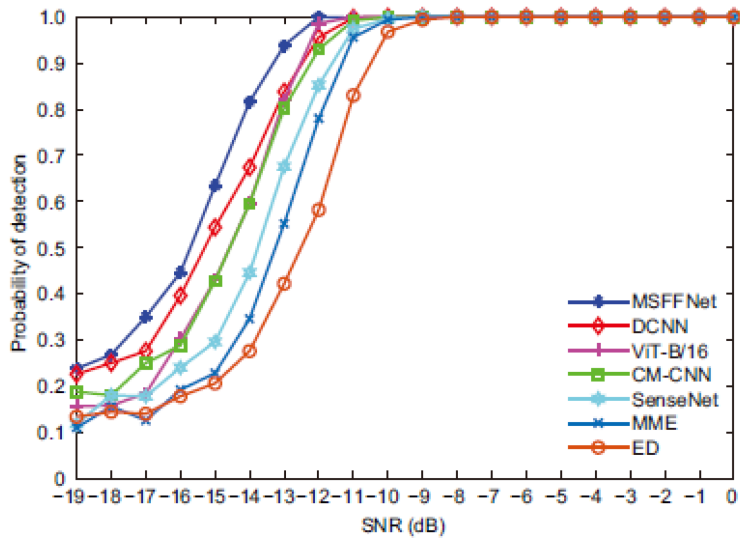

Table 4 Comparison of the complexity of spectrum sensing models

Model	Memory (MB)	$N_{\text{par}} (\times 10^6)$	$N_{\text{MACs}} (\times 10^6)$	$P_d$
SenseNet	17.89	4.21	5.32	0.464
DCNN	22.18	0.10	76.41	0.782
MSFFNet	104.49	22.22	969.62	0.936
CM-CNN	107.36	25.63	138.86	0.618
ViT-B/16	735.83	85.80	16 880	0.818

$N_{\text{par}}$ : number of parameters;  $N_{\text{MACs}}$ : number of MACs

Table 5 Comparison of training and inference time for spectrum sensing models

Model	Training time (s)	Inference time (ms)
SenseNet	494	1
CM-CNN	596	2
DCNN	577	2
MSFFNet	851	4
ViT-B/16	4532	9

Fig. 12 Detection performance of spectrum sensing methods under colored noise: (a)  $P_d$ -SNR curves; (b) ROC curves

# Conclusions

In this work, we propose a novel spectrum sensing method based on a multi-scale feature fusion network (MSFFNet) to address the feature extraction limitations of traditional CNNs under low-SNR conditions. By integrating multi-scale feature extraction, adaptive feature screening, and multi-level feature fusion, the proposed method effectively captures local and global signal characteristics. Experimental results demonstrate that MSFFNet significantly outperforms existing sensing models in low-SNR scenarios at the same false alarm probability, providing useful insights for intelligent spectrum sensing in complex wireless environments.



Kejun LEI received her BS degree in electronic information engineering from Jishou University, China, in 2002, the MS degree in circuits and systems from Hunan University, China, in 2007, and the PhD degree in electrical engineering from Hunan University, China, in 2018. She is currently a Professor and a Master's Supervisor in electronic information engineering at Jishou University. Her research interests include smart grids, digital signal processing, and cognitive radio.