

Cite this as: Guan-yi Chen, Wan-qing Li, Hong Chen, Bei-bei Yan, 2015. Progress in the aqueous-phase reforming of different biomass-derived alcohols for hydrogen production. *Journal of Zhejiang University-SCIENCE A (Applied Physics & Engineering)*, 16(6):491-506. [doi:10.1631/jzus.A1500023]

Progress in the aqueous-phase reforming of different biomass-derived alcohols for hydrogen production

Key words:

Biomass, Alcohols, Hydrogen, Aqueous-phase reforming (APR)

Mechanism of the aqueous-phase reforming of alcohols

Main Reaction:

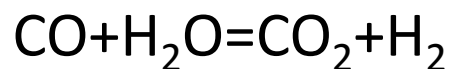
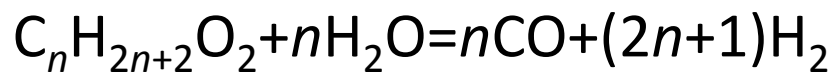

Secondary Reaction:

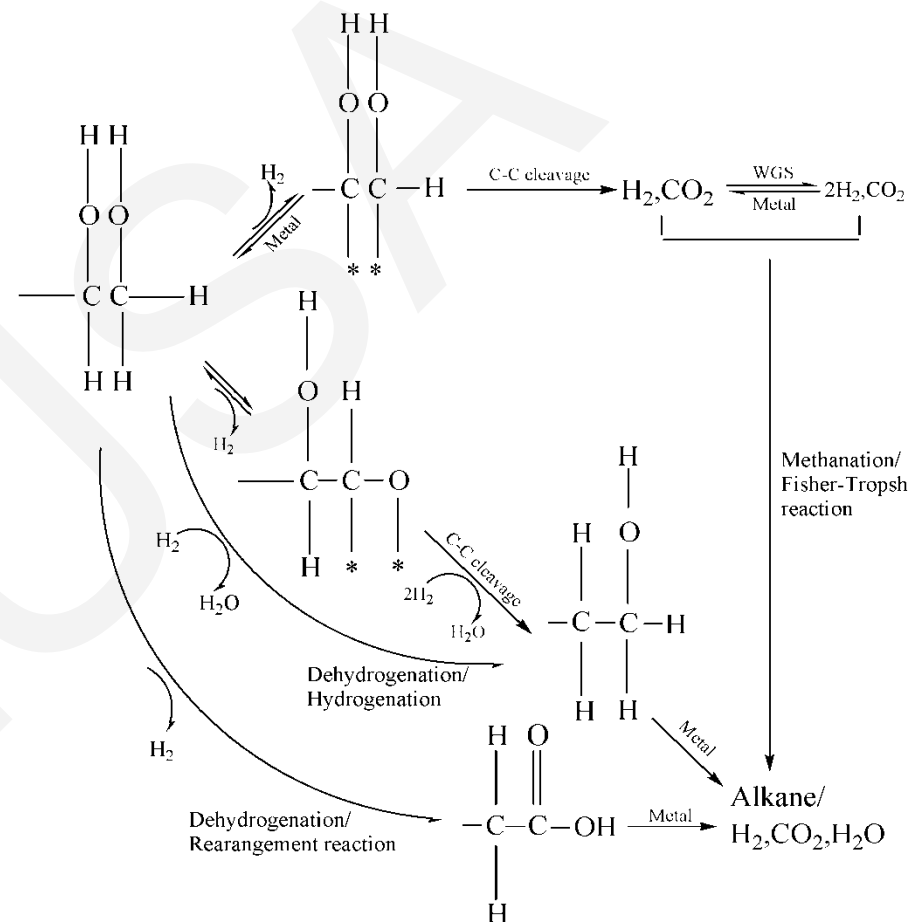
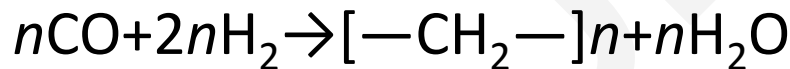
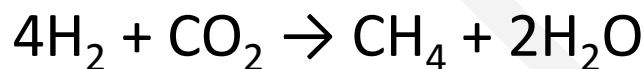
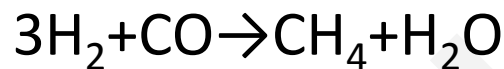

Fig. 1 Reaction pathways for production of H₂ by an aqueous-phase reforming process

Aqueous-phase reforming of ethylene glycol

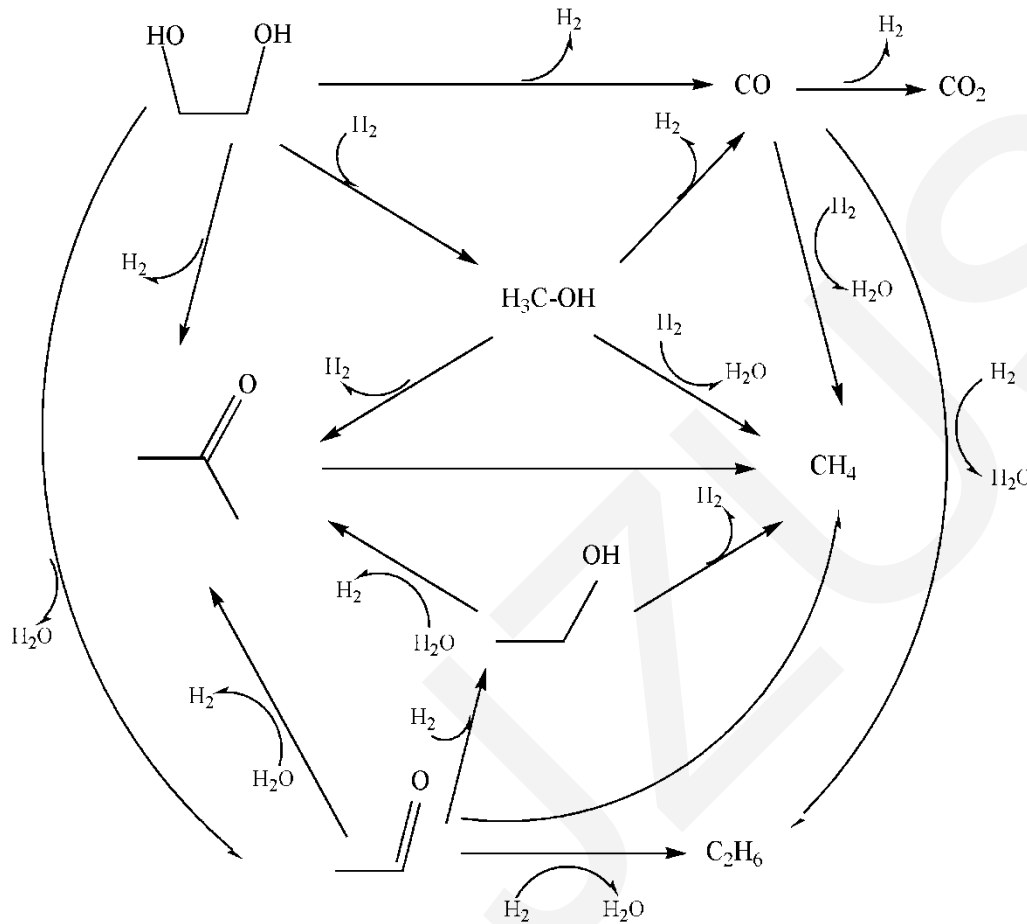

Fig.2 Reaction pathways for ethylene glycol reforming

- Noble metal such as Pt, Pd, Ru, Rh and Ir were utilized.
- The addition of other metals (Re, Mn, Fe, Cs, Ba, Ga, Ag, Mo, Mg, Ce, Ni, Co et al) reduced the cost of the catalyst while maintaining the catalytic activity.
- Catalysts prepared by non-noble metal such as Co/ZnO, NiAl/HT were also used in APR of ethylene glycol

Aqueous-phase reforming of glycerol

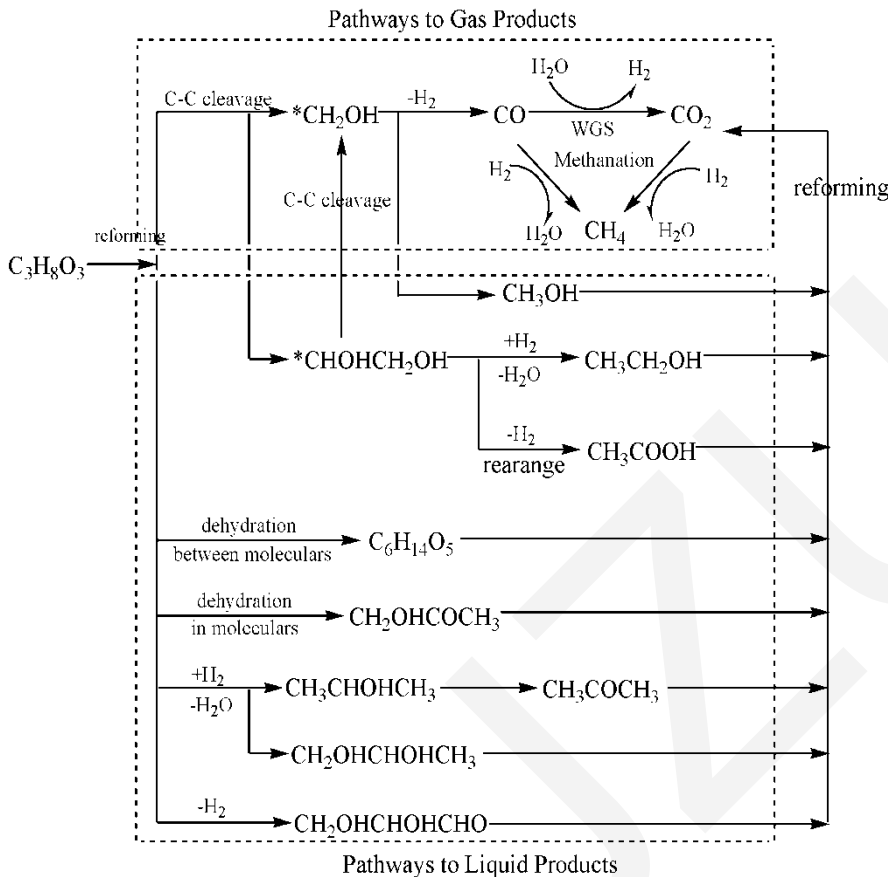

Fig. 3 Possible reaction network for the aqueous-phase reforming of glycerol

Pt-based catalysts

- The catalyst Pt/Al_2O_3 remains the most commonly applied.
- The reaction is sensitive to the particle size and metal surface.
- Re, Mo, Co, Ni were doped into the catalysts to improve the activity.

Ni-based catalysts

- Ce, B, Co and Cu were added to reduce the deactivations of Ni catalysts.

Supports

- Supports, such as Al_2O_3 , CeO_2 , MgO , SiO_2 , etc, also play an important role in the APR of glycerol.

Aqueous-phase reforming of other alcohols

Alcohols	Source	Catalysts
n-BuOH	fermenting sugar beets, sugar cane, corn, wheat, lignocellulosic biomass, and aqueous fractions of biomass pyrolysis liquids	Ni/Al ₂ O ₃ Ni/CeO ₂
Sorbitol		Pt-Ni Pd-Ni Pd-Ni/ γ -Al ₂ O ₃ Pt-Ni/Al _n f, ZrO ₂ , CZxS
Xylitol	produced by the catalytic hydrogenation of xylose monomers generated from hemicelluloses	Pt/Al ₂ O ₃ Pt/TiO ₂ Pt-Re/TiO ₂ Pt/C

Conclusions

- The APR of ethylene glycol and ethanol on Pt-based catalysts presented high conversion but low H₂ yield, and little research on non-noble metal catalysts was performed.
- The conversions of n-butanol on the Ni/CeO₂ and Ni/Al₂O₃ catalysts were rather low, whereas the H₂ selectivity was high.
- Degradation and condensation took place with an increase in molecular weight of the alcohols.
- The APR process is still at the research and development stage. And a new reactor is hoped to be designed.