



Cite this as: Jia-chuan YAN, Xiao-fei JIN, Feng QIN, Zheng LI, Feng FAN, Jin-ping OU. Modular construction mechanics of a European pressurized reactor steel containment liner. *Journal of Zhejiang University-SCIENCE A (Applied Physics & Engineering)*, 18(6):467-486. <http://dx.doi.org/10.1631/jzus.A1600136>

Modular construction mechanics of a European pressurized reactor steel containment liner

Key words: Containment, Construction mechanics, Steel liner, Overlapping element, Birth-death element

INTRODUCTION

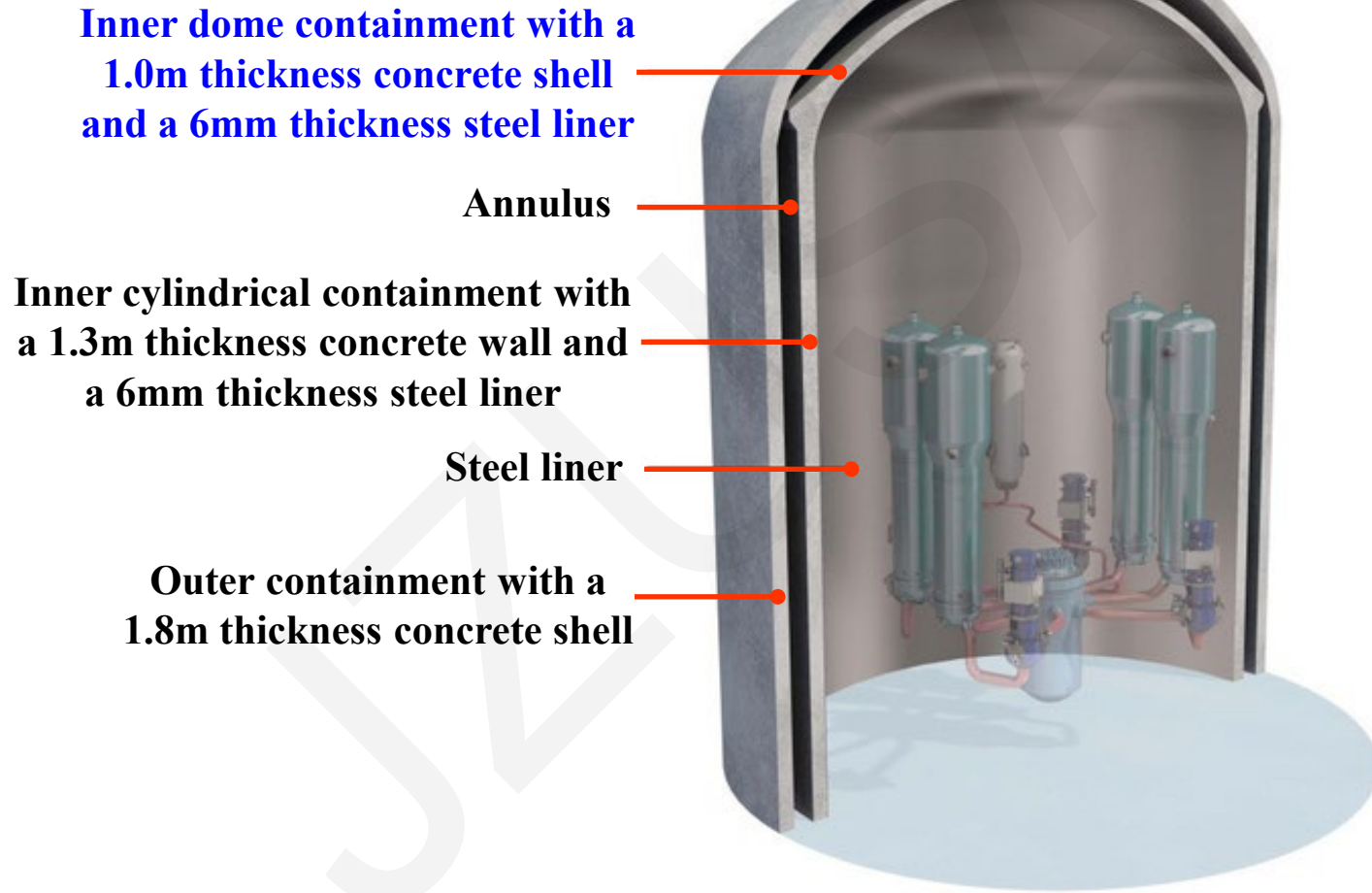

Containment structure for an EPR reactor building (ASN, 2015)

ANALYSIS OF LIFTING OF STEEL LINER MODULES



Lifting of the cylinder module

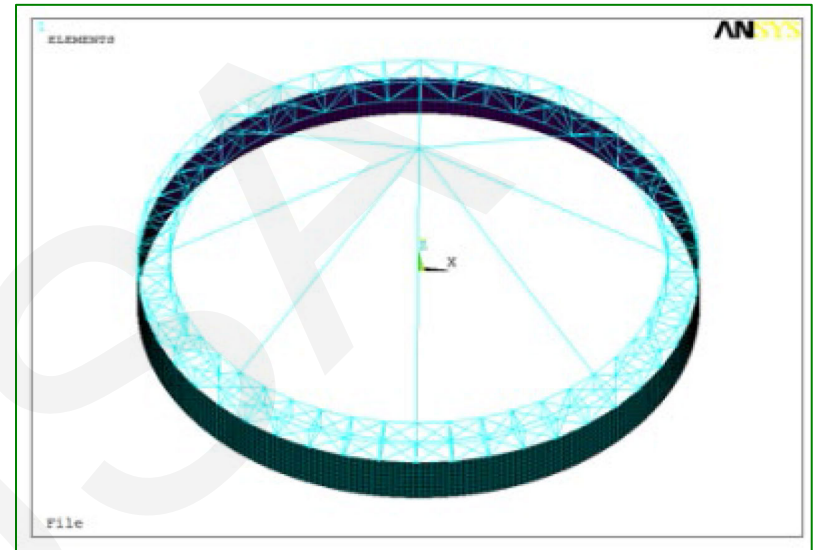

Analysis model for lifting the cylinder module

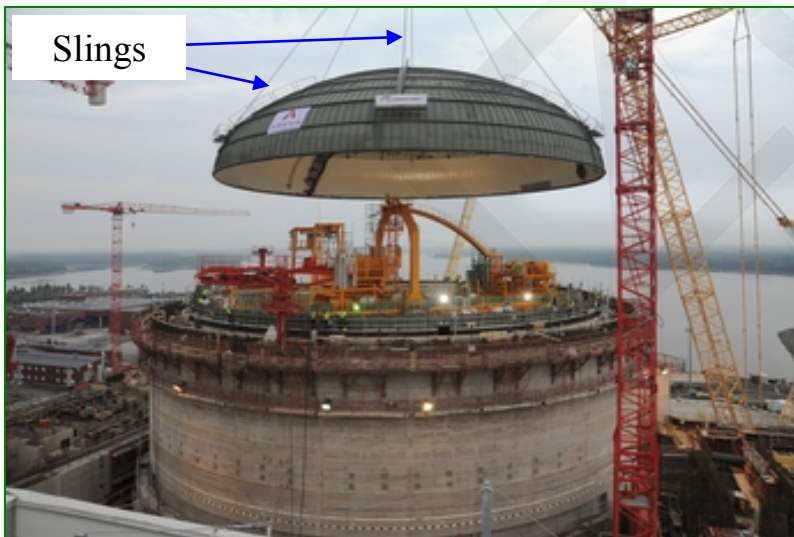

Lifting of the dome module

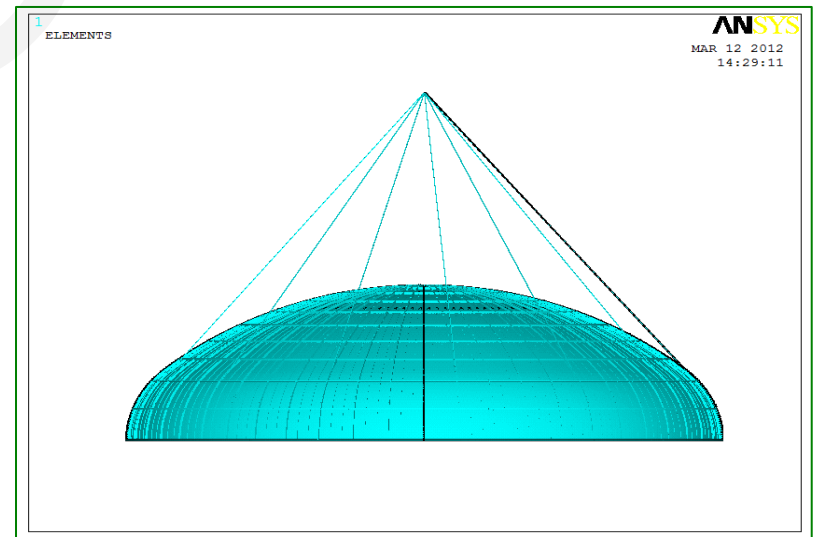

Analysis model for lifting the dome module

CONSTRUCTION MECHANICAL PERFORMANCE OF THE STEEL CYLINDER LINER MODULES

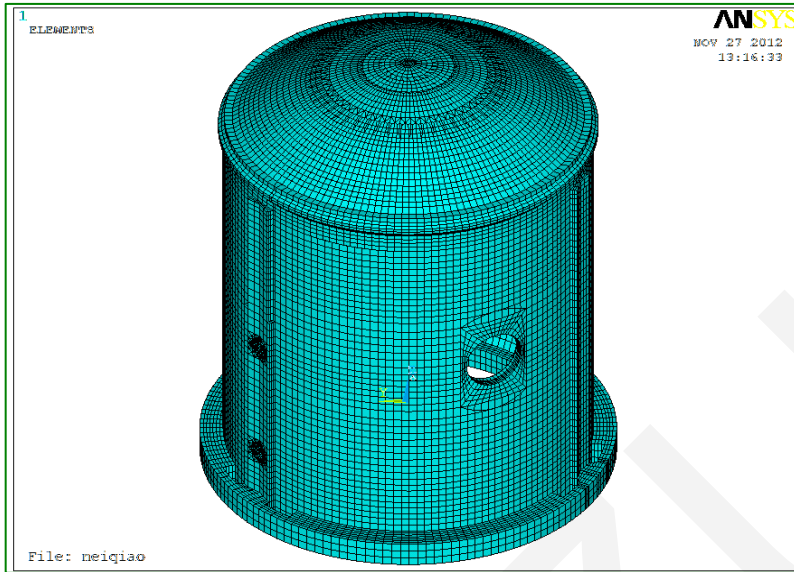

FE model of the inner containment structure

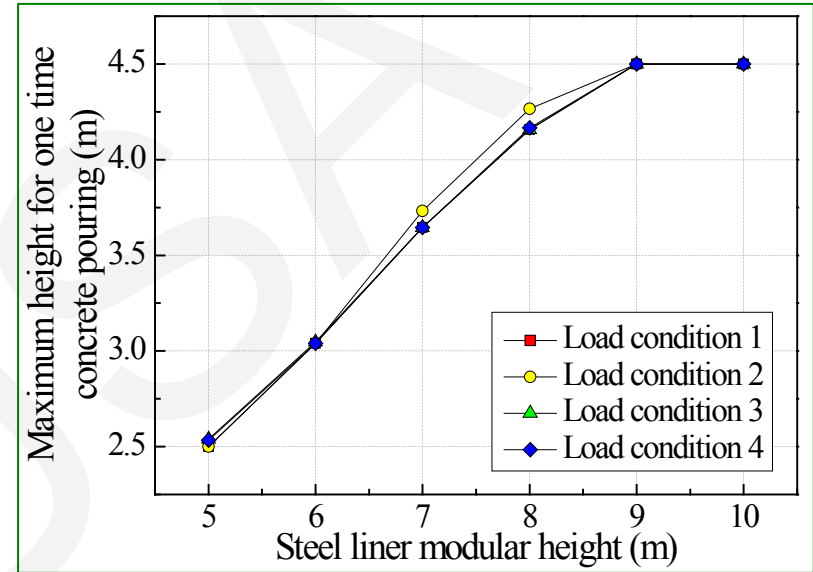

Steel liner modular height - the maximum height of a concrete pouring at any time

Load action	Load Condition 1	Load Condition 2	Load Condition 3	Load Condition 4
Lateral pressure of the concrete pour	Considered	Considered	Considered	Considered
Preliminary assembly internal force	Considered	Considered	Considered	Considered
Wind pressure height (m)	40.0	20.0	40.0	20.0
Sunshine temperature difference (°C)	10.0	10.0	5.0	5.0

TIME-VARYING STRUCTURAL PERFORMANCE OF THE INNER DOME CONTAINMENT STRUCTURE DURING CONSTRUCTION

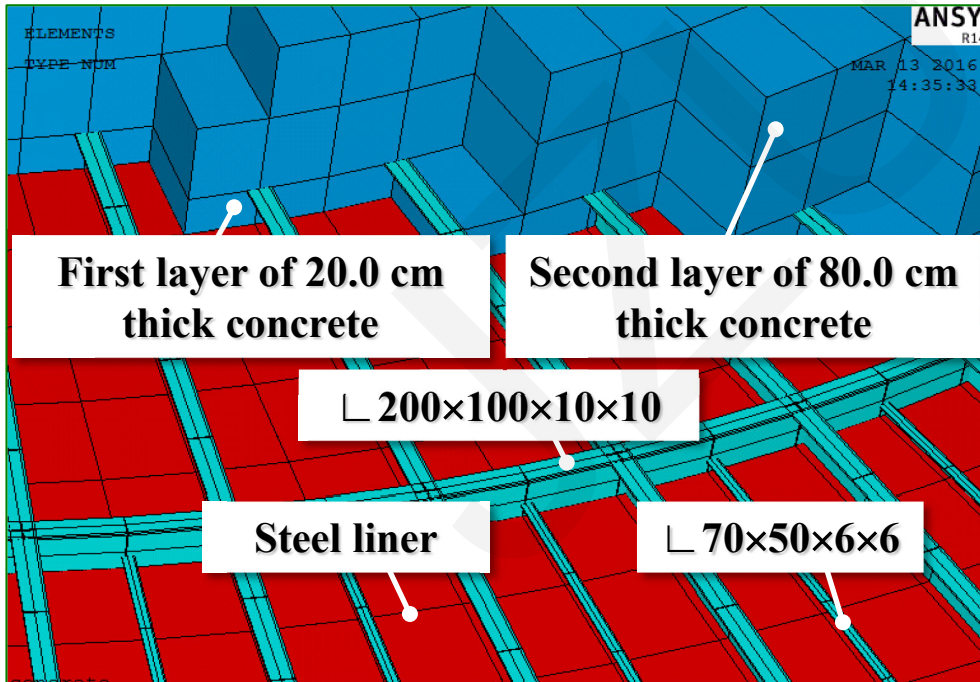
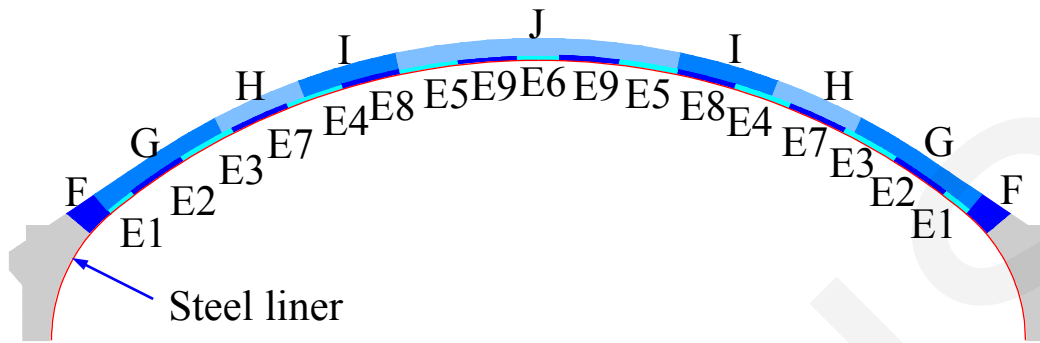

Pouring of first layer of 20.0 cm thick concrete	
Construction layers	Construction periods (d)
E1、 E2	15
F	97
E3	1
E4	1
E5	1
E6	1
E7	1
E8	1
E9	1
Pouring of second layer of 80.0 cm thick concrete	
G	7
H	14
I	14
J	7

STRUCTURAL ANALYSIS DURING CONSTRUCTION

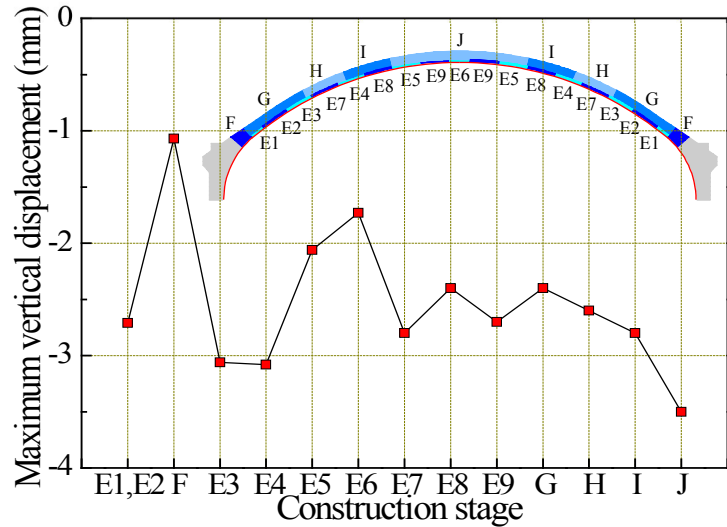

Maximum vertical displacement of the steel liner during different construction stages

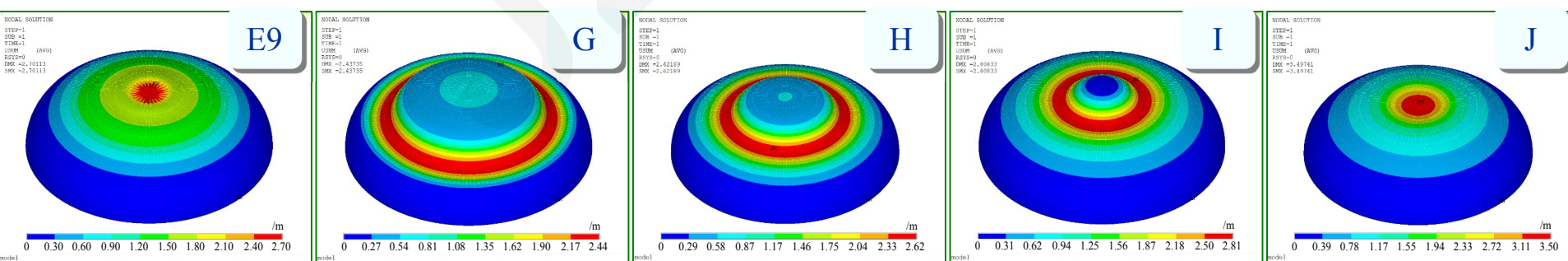
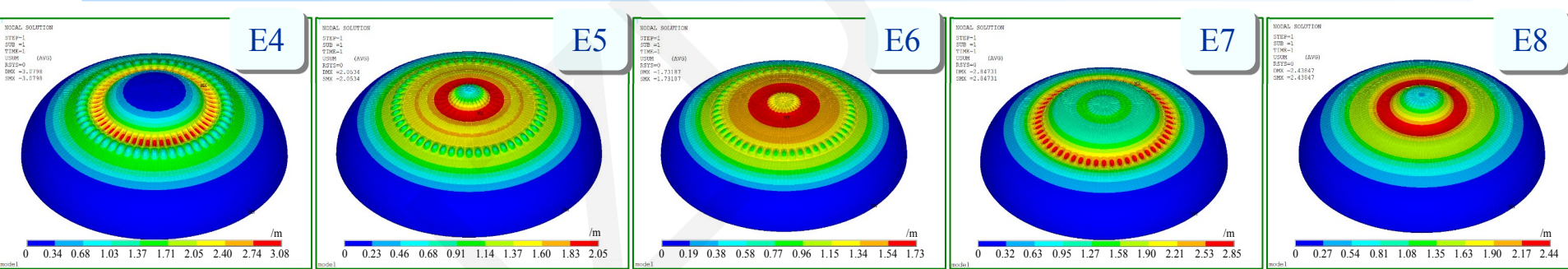
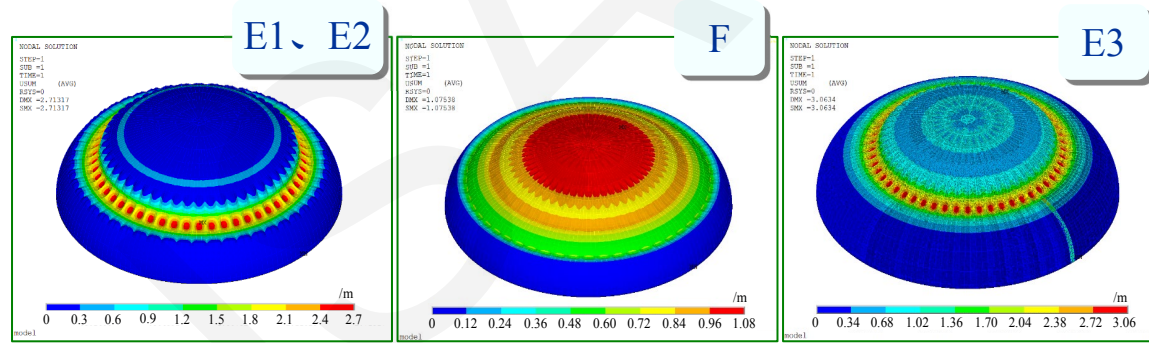

RESULTS AND CONCLUSIONS

- In considering the application of modular construction technology for the steel liner of the inner containment structure, three key problems were identified and analyzed in detail.
- Compared with the circular space truss with the quadrilateral cross section, new lifting equipment using a circular space truss with the triangular cross section is proposed, which can satisfy stress and de-formation requirements and can reduce steel consumption by approximately 20.0%. During the lifting of the dome module, the maximum vertical deformation is only 1.30 mm without the vertical rigid body displacement. In addition, the maximum von Mises stress of the lifting lug is 115 MPa. During the lifting of the dome module, the working wind speed should be controlled to within 6.17 m/s.
- The relationship between the steel cylinder liner modular height and the maximum height of each concrete pouring was determined. The result shows that the height of the steel cylinder liner module can be increased if the capacity of the crane is sufficient.
- The “overlapping element and birth-death element” technique was adopted to simulate the construction process for concrete pouring, while the calculation for a load step was based on the calculation for the previous step. The mechanical properties of the steel dome liner after the concrete pouring were obtained. Two key phases have been defined for the stability analysis of the steel dome liner during the whole construction process encompassing the concrete pouring on the steel dome liner, and the corresponding stability analyses were carried out. The results show that the construction scheme is reasonable.
- Based on the FE method, a practical method of modeling and nonlinear analysis is proposed which provides guidance on the design and analysis for the construction of the containment structure.