

# Laser frequency locking with low pump field saturated absorption spectroscopy

Shang-qing Liang

Cite this as: Shang-qing Liang, Yun-fei Xu, Qiang Lin, 2018. Laser frequency locking with low pump field saturated absorption spectroscopy. *Journal of Zhejiang University-SCIENCE A (Applied Physics & Engineering)*, 19(2):171-174.  
<https://doi.org/10.1631/jzus.A1700142>

# Basic Principle

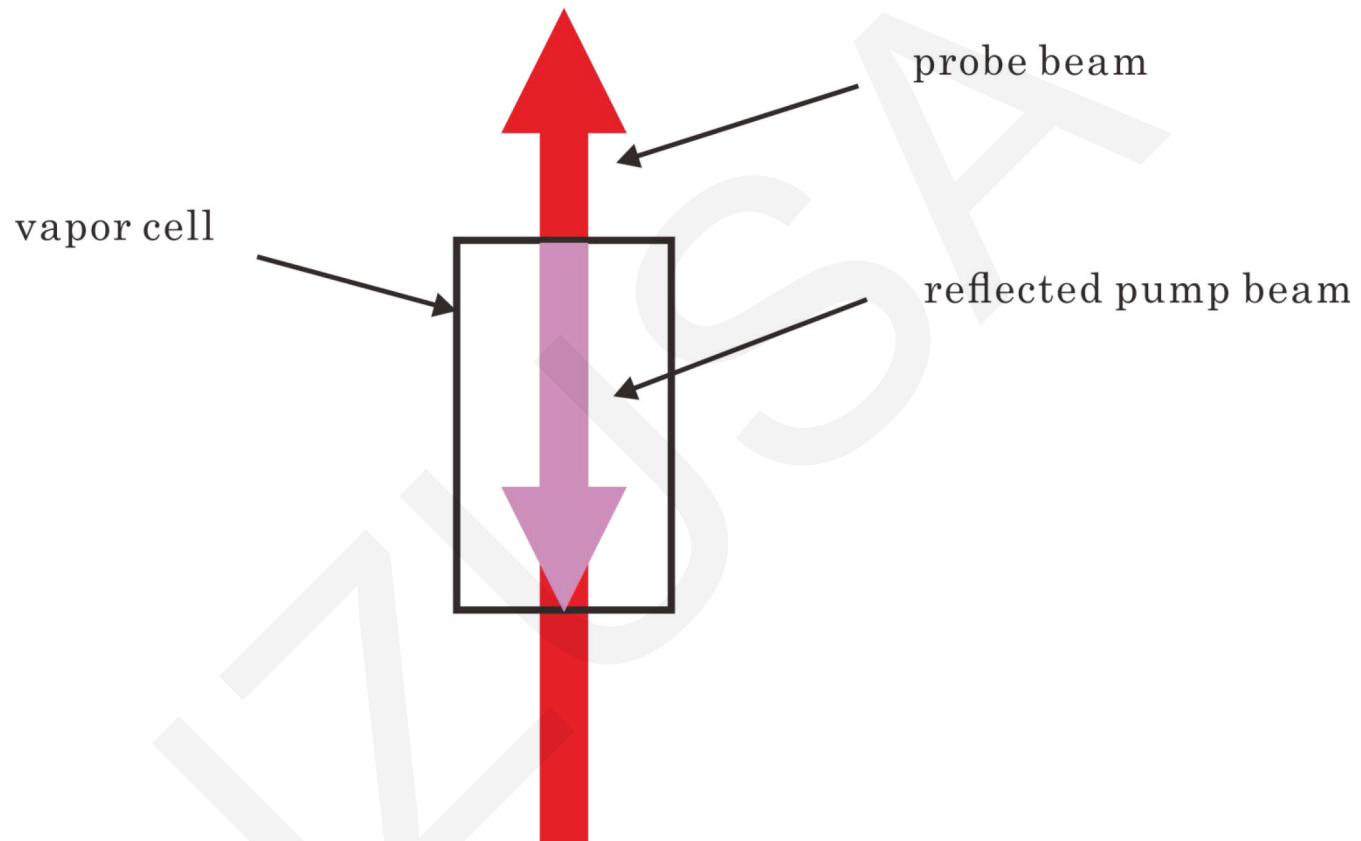

**Fig.1 Low pump field saturated absorption spectroscopy scheme. The probe beam travels through the vapor cell and the reflected light from the inner surface is the pump field.**

# Experimental set-up

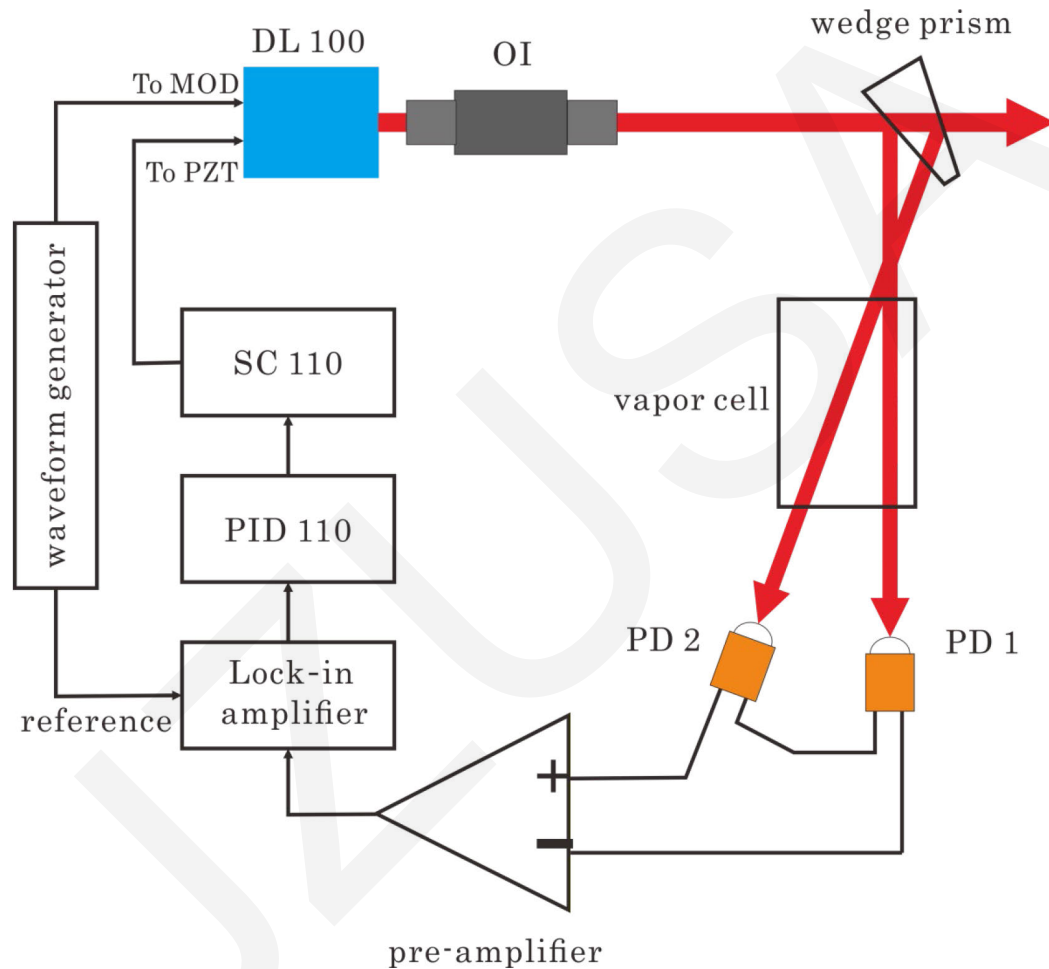

**Fig.2 Experimental apparatus. OI: optical isolator; PD: photodiode detector; MOD: current modulation input in-terface; PZT: Piezoelectric ceramic.**

# Result and discussion

## ■ Incident angle and relative intensity

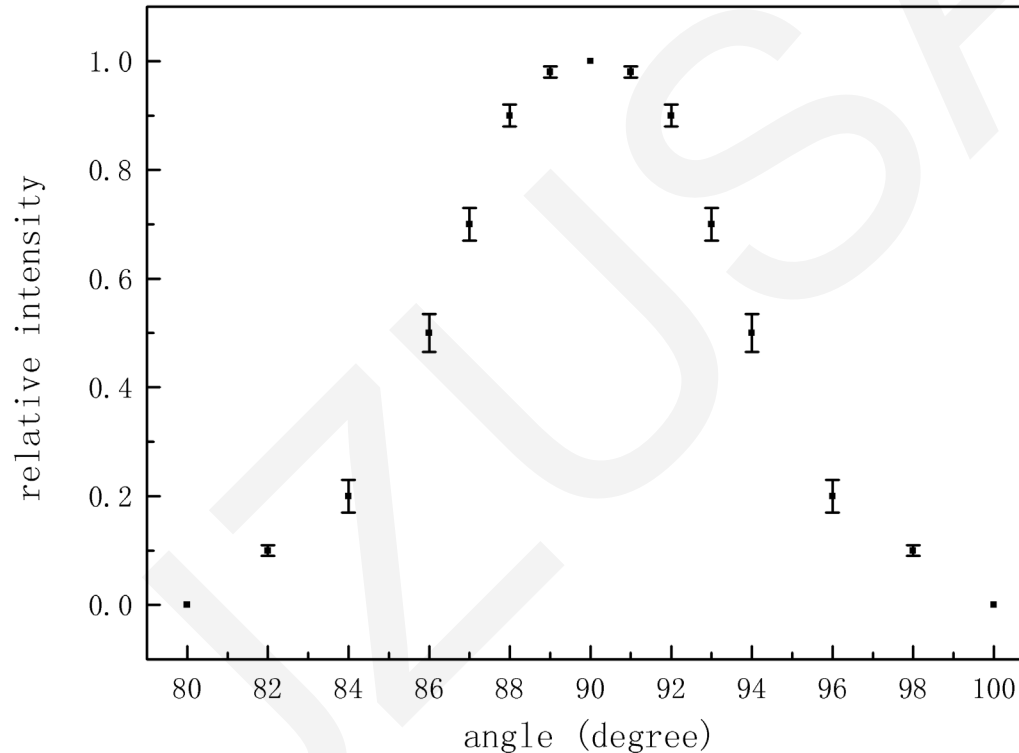

**Fig.3 The relationship between incident angle of the probe beam and the relative intensity of the signal.**

# Result and discussion

## ■ Lock-in effect

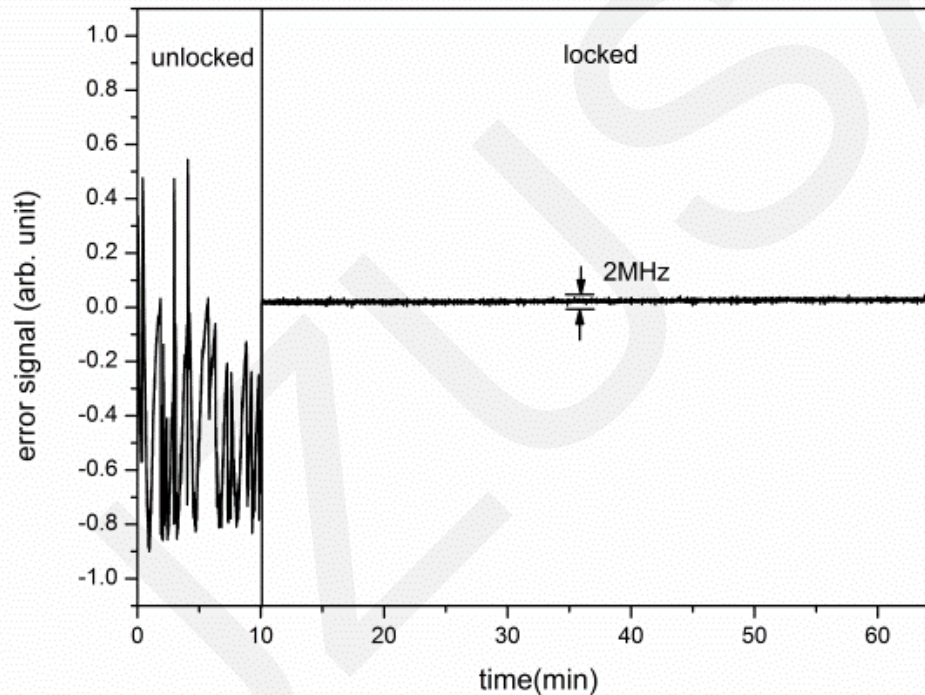

**Fig.4 Error signals before and after the frequency of the laser is locked.**

# Conclusions

- We put forward and demonstrate experimentally a laser frequency locking method using low pump field saturated absorption spectroscopy. Compared with traditional high pump-low probe configuration, our low pump-high probe configuration is much simpler. There is no additional reflecting mirror in the scheme, and so it is less sensitive to vibration than the traditional scheme. It is a technique that can find application in precision measurement systems on moving platforms.