

Universität Stuttgart

Institut für Chemische Verfahrenstechnik

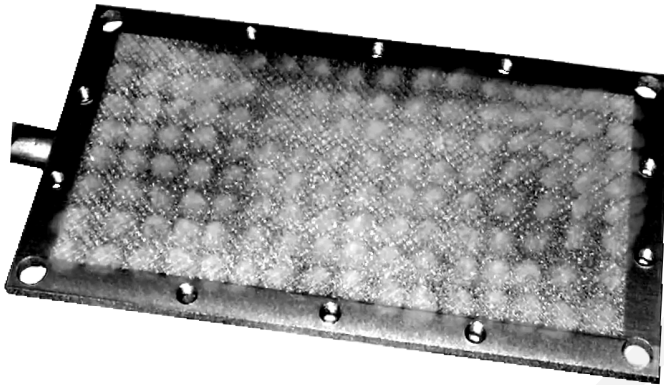

20.08.2018



Development of a spatially uniform low-temperature hydrogen combustor

Cite this as:

Hendrik Dubbe, Elena Holl, Adriaan Spierings, Konrad Wegener, Ulrich Nieken, 2018. Development of a spatially uniform low-temperature hydrogen combustor. *Journal of Zhejiang University-SCIENCE A (Applied Physics & Engineering)*, 19(10):735-745.

<https://doi.org/10.1631/jzus.A1700620>

H. Dubbe • E. Holl • A. Spierings •

K. Wegener • U. Nieken

Purpose of the study

- Example of the use of additive manufacturing and rapid prototyping in a range of applications
- Here: A catalytic low temperature burner for H₂ on a lab scale with an integrated flow distributor
- Combustor was designed, manufactured and successfully tested for functionality.
- Also a great variety of possible design proposals is discussed.

Method or procedure

- Based on a theoretical approach, a flow distributor for the burner was designed and a prototype built using fused deposition modeling (FDM).
- Based on test results, an optimized version of the burner was then designed and manufactured using selective laser melting (SLM).

Design of the burner unit

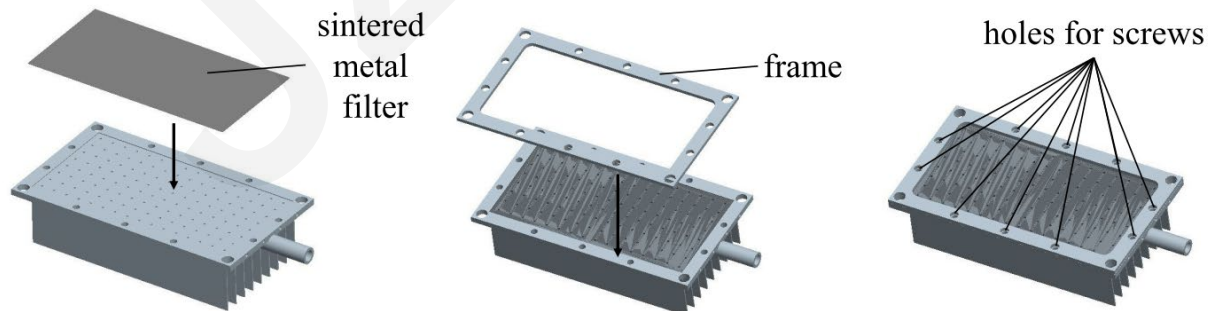
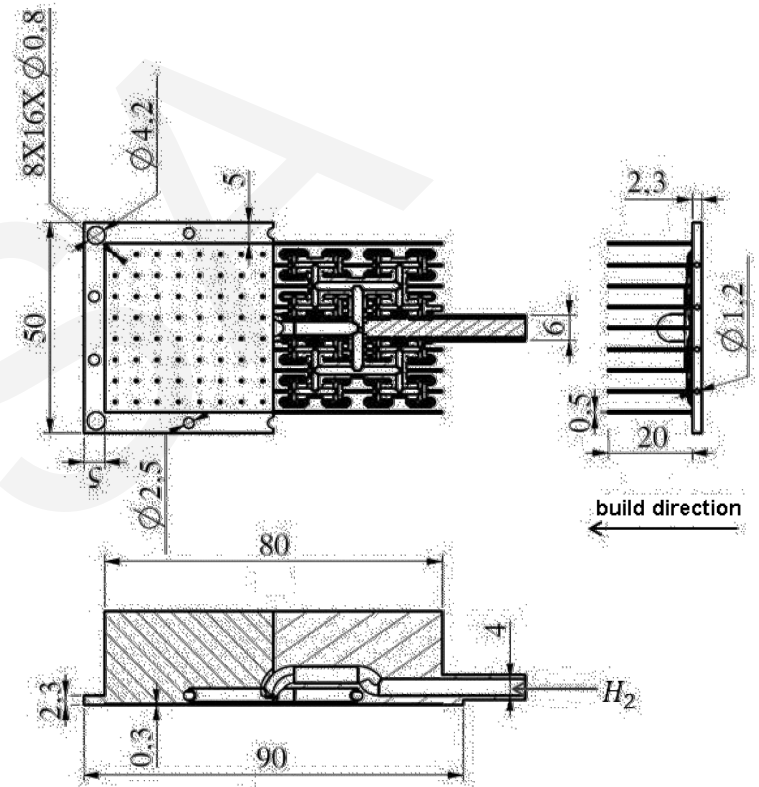
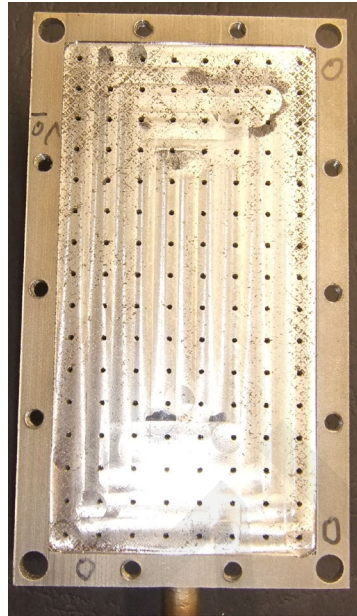
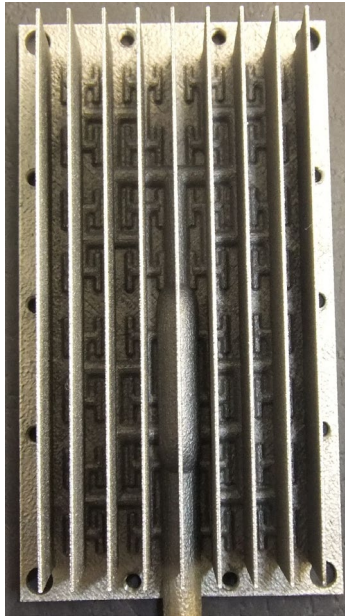

Dimensions of burner unit and containment

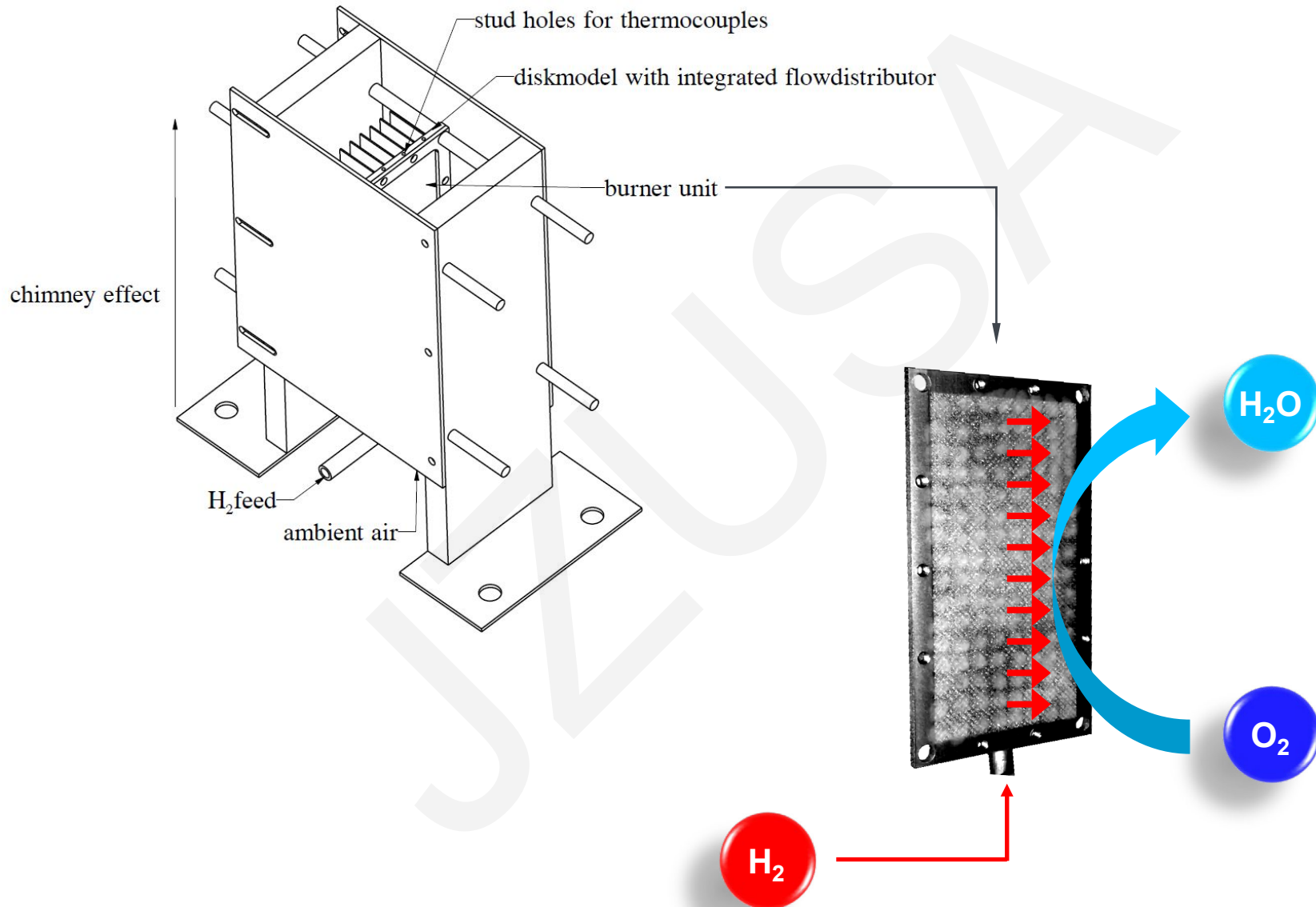

Conclusions

- Theoretically based branched-tree approach was realized in order to distribute the gas evenly over a catalytic surface.
- Constant oxygen supply was ensured by an enclosure generating a chimney effect for ambient air. The concept was successfully tested for functionality.
- Such fractalized fluid flow systems could also be of interest in other chemical process engineering applications.

Outlook

- The formation of special holes for the placement of thermocouples in the center of the distributor could also be easily implemented in the manufacturing process.
- Additive manufacturing of porous structures as catalyst carriers could be integrated into the process. This has the advantage that such structures could be produced with defined porosity, a more deterministic channel size and reliable strength.