



Cite this as: Feng SUN, He XU, Yu-han ZHAO, Yu-dong ZHANG, 2022. Data-driven fault diagnosis of control valve with missing data based on modeling and deep residual shrinkage network. *Journal of Zhejiang University-SCIENCE A (Applied Physics & Engineering)*, 23(4):303-313. <https://doi.org/10.1631/jzus.A2100598>

Data-driven fault diagnosis of control valve with missing data based on modeling and deep residual shrinkage network

Key words: Control valve; Missing data; Fault diagnosis; Mathematical model; Deep residual shrinkage network



INCOMPLETE FEATURE DATA OF CONTROL VALVE

- The search focus on the problem of fault diagnosis with data imbalance and incompleteness in the control valve system.
- This paper designs a hybrid method combining the control valve mathematical model (MM) and the data-driven model.
- The contribution of this research is to accurately realize the fault diagnosis of the control valve from the unbalanced and incomplete data by constructing a balanced sample set.

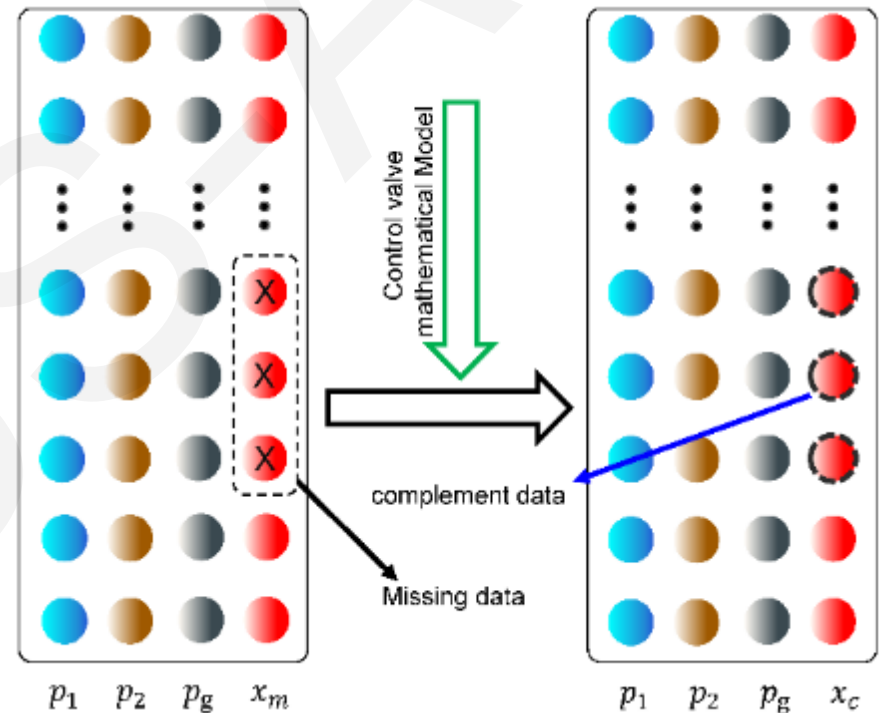

Figure. Schematic diagram of complement feature based on a control valve mathematical model (p_1, p_2 and p_g are the pressure before and after the control valve, and the gas pressure in the valve, respectively. x_m is the valve opening with missing data, x_c is the completed valve opening after imputation)

METHOD

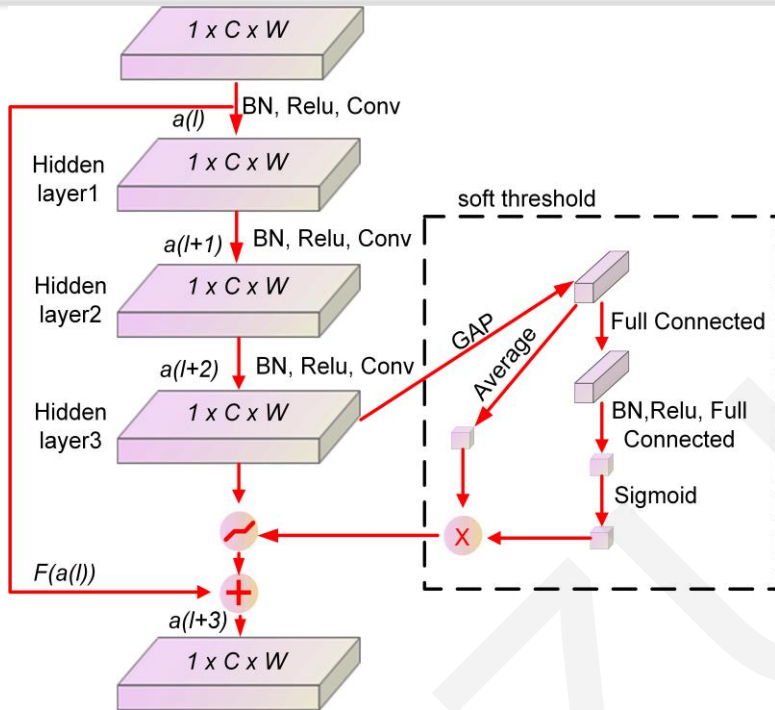

Figure Deep Residual Shrinkage Network with channel-shared thresholds

- The core content of the MM is to combine the model with data and use a simplified model that can reflect the physical relationship to describe the state of the control valve. According to the data model of the control valve and other complete data, the missing data of the control valve can be interpolated.

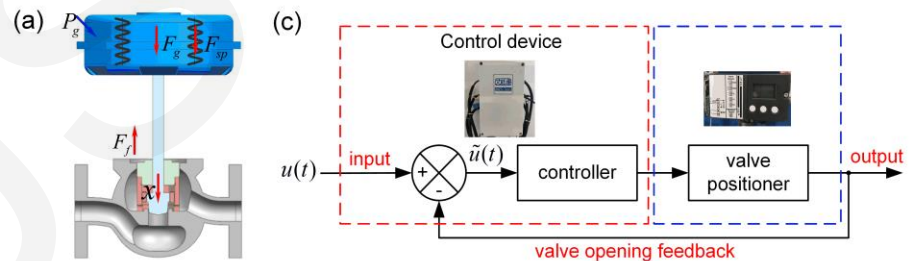

Figure (a) Mathematical model of pneumatic control valve; (b) The physical map of the test system: water hydraulic system, test control valve and sensors; (c) The control loop diagram of control valve

- The deep residual shrinkage network (DRSN) is a deep learning method for noisy data. By introducing the soft threshold and attention mechanism into the DRSN, a threshold-sharing deep residual shrinkage unit is constructed to overcome the noise of data samples generated by pressure fluctuations.

RESULTS AND CONCLUSIONS

- According to the experimental design results in the previous part, the DRSN and MDRSN algorithms have better fault diagnosis effects for imputation models with different data missing rates. Furthermore, to verify the validity of the MDRSN proposed in this paper, the fault diagnosis accuracy rates of DRSN and MDRSN were compared under different imputed data sets.
- The accuracy fault diagnosis of MDRSN has some improvement compared with DRSN. Compared with DRSN, MDRSN deletes missing data sets, random imputation data sets, KNN imputation data sets, and MM imputation data sets. The fault diagnosis accuracy has increased by 4.9%, 2.14%, 1.06%, and 0.95%, respectively.

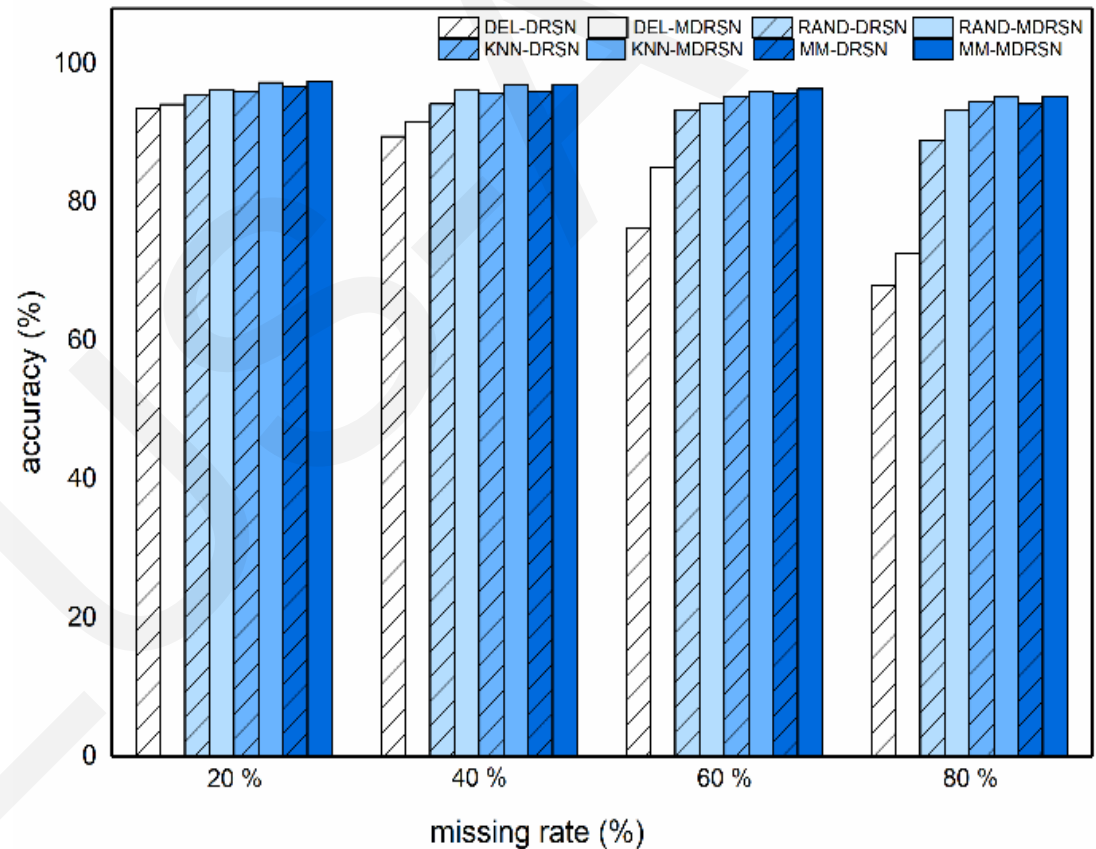

Figure Comparison of classification accuracy for DRSN and MDRSN with variable handling incomplete data and missing rate

APPLICATION

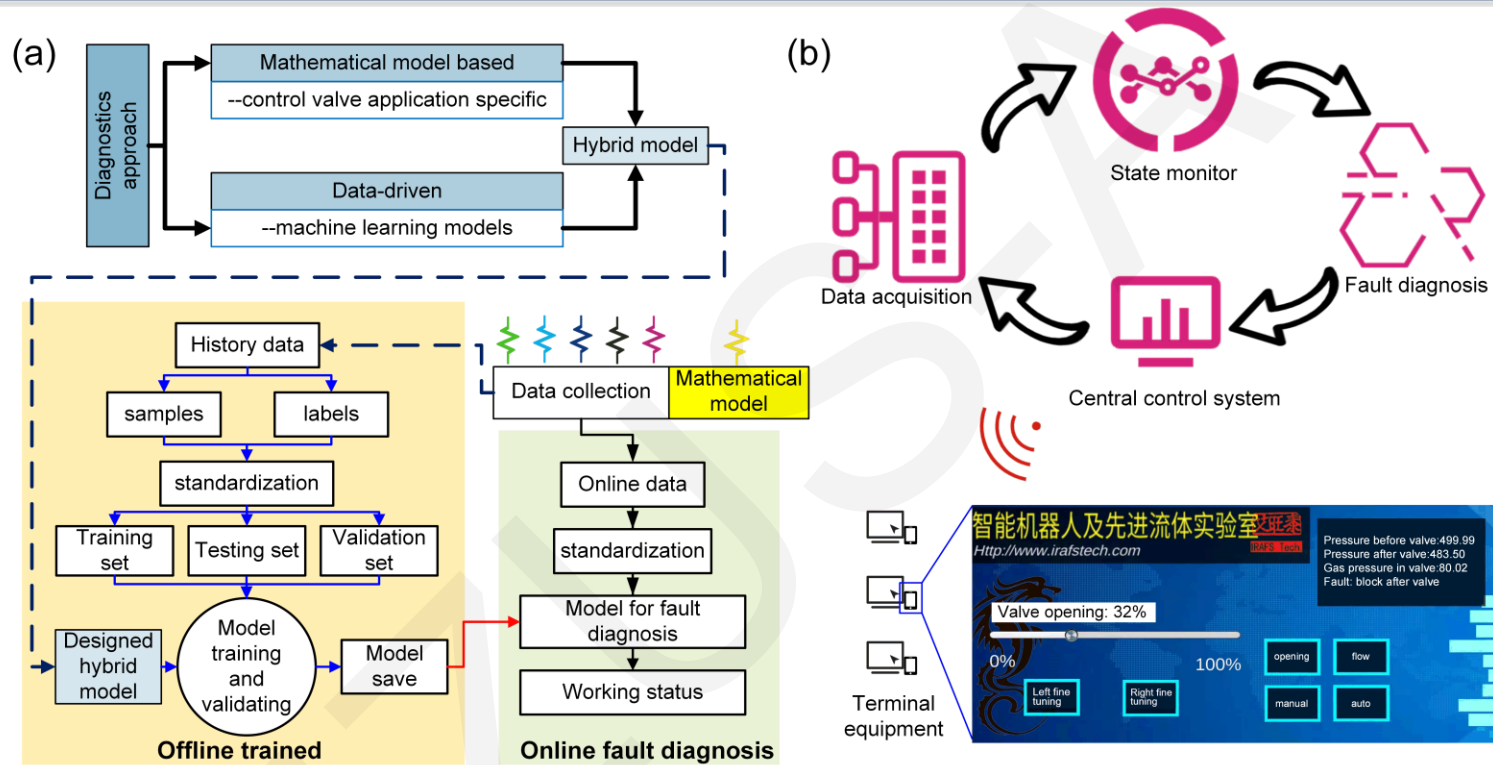

Figure (a) Flowchart of the proposed online control valve fault diagnosis model; (b) Control valve online fault diagnosis system and terminal equipment operation interface (pressure unit: kPa)

- The online fault diagnosis system and the terminal effect diagram of the control valve. The controller transmits the sensor information and diagnosis results to the mobile terminal in real-time via the wireless network.