

Cite this as: Xinghai ZHOU, Yakun ZHANG, Guofang GONG, Huayong YANG, 2025. Impact of disc-cutter partial wear on tunneling parameters and a high-accuracy method for discrimination of partial wear. *Journal of Zhejiang University-SCIENCE A (Applied Physics & Engineering)*, 26(4):359-375.

<https://doi.org/10.1631/jzus.A2400068>

## Impact of disc-cutter partial wear on tunneling parameters and a high-accuracy method for discrimination of partial wear

### Key words:

Tunnel boring machine (TBM), Disc cutter, Partial wear, Tunneling parameters, Multi-domain features, Ensemble learning

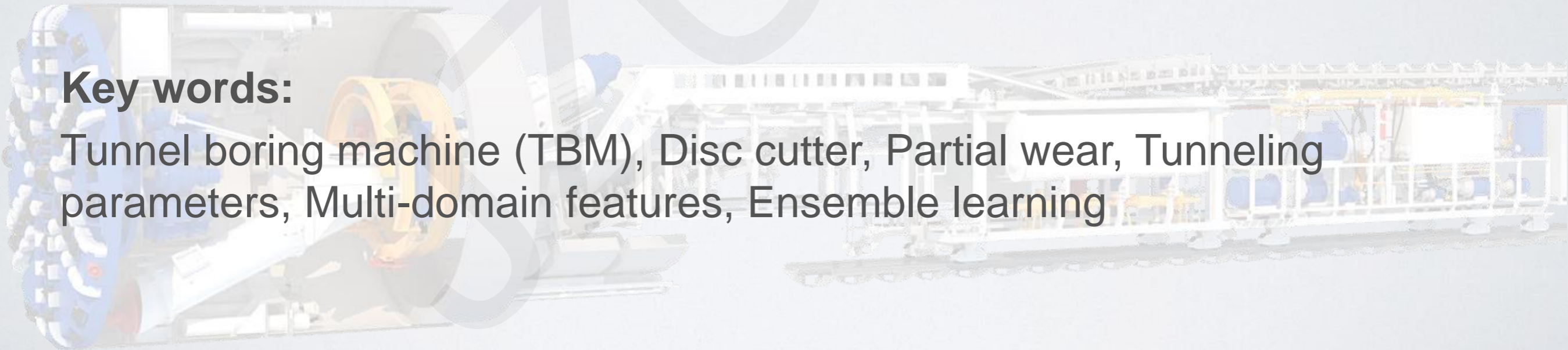

# Disc-cutter Partial Wear



Partially worn cutters

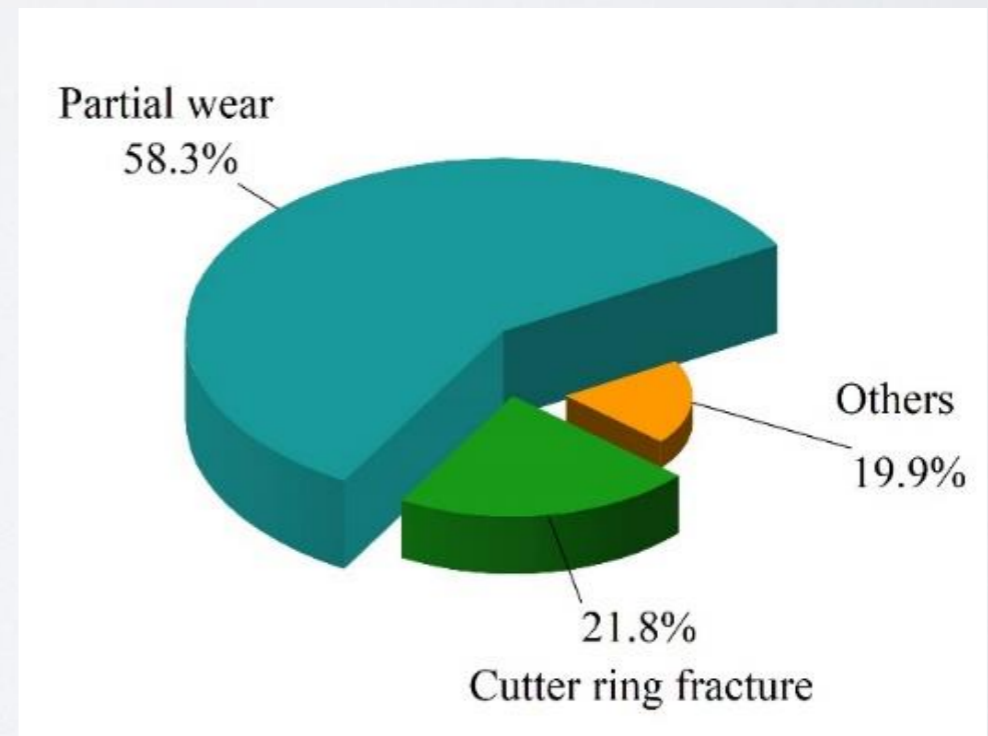

Proportions of Abnormal Damage

# Research Methodology

Tunneling parameters change with the occurrence of partial wear

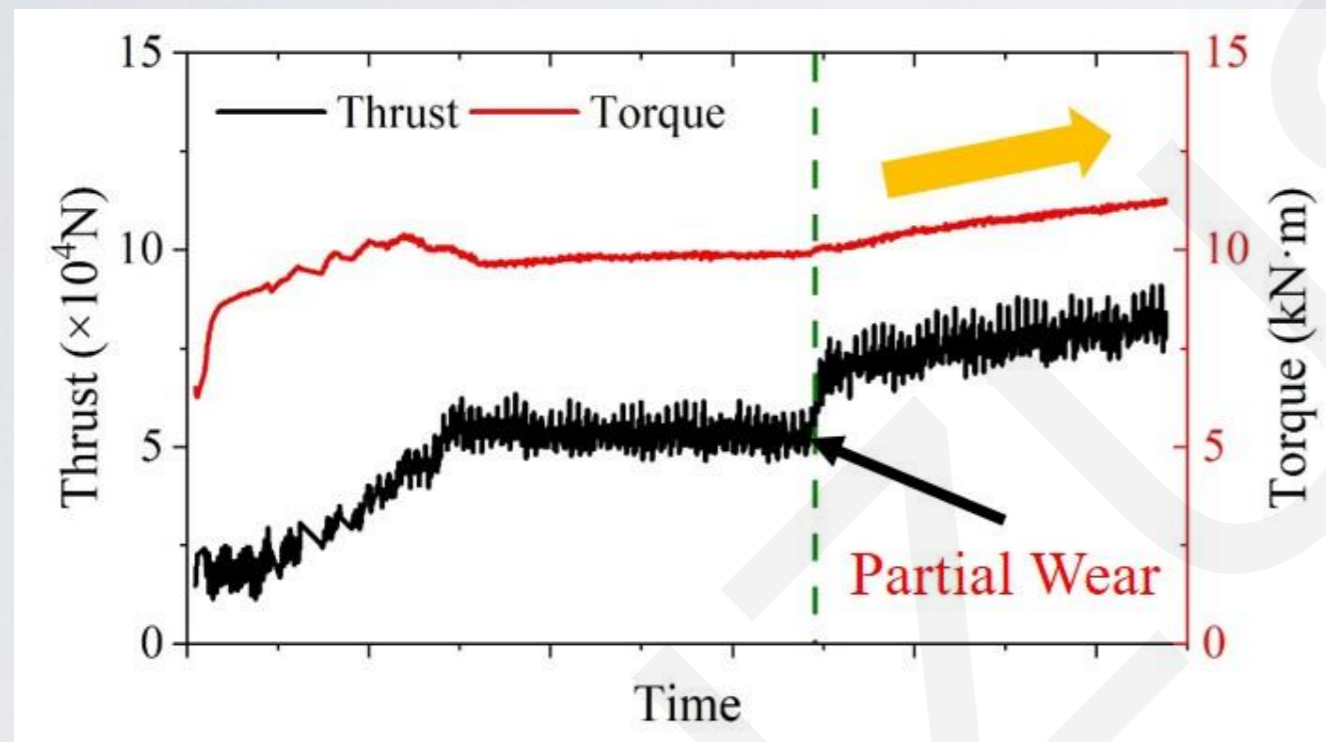

## Experimental Study

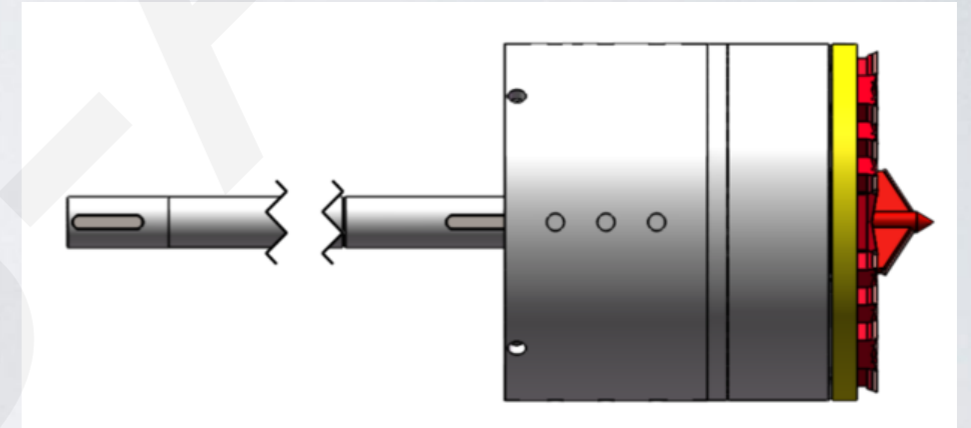

- Analyze changes in tunneling parameters
- Create a dataset for developing models

## Partial-wear-ratio discrimination

- Multi-domain feature extraction
- Model for partial-wear-ratio discrimination

(a)



Cutterhead

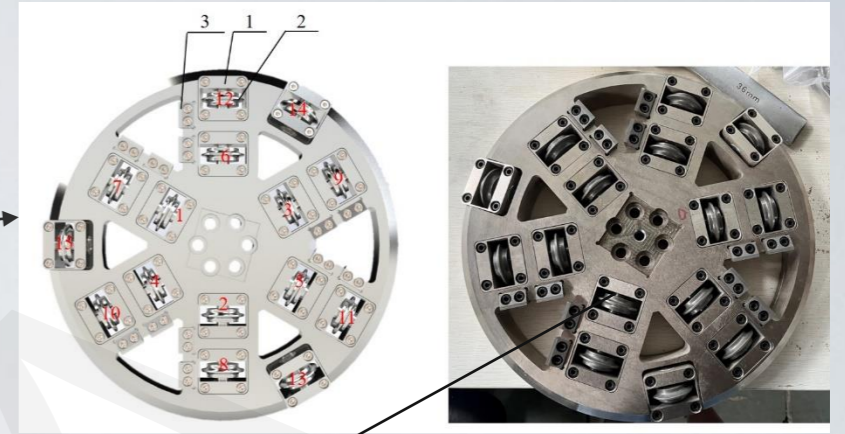

Normal cutter      Trapped cutter      Partially worn cutter



Round shafts      Square shafts      Cutting

(b)

Soil fill

Test rig adjustment

Cutter installation



Exit

Shield tunneling

Rig operation

(c)

Torque and thrust increase with the increasing number of partially worn disc cutters

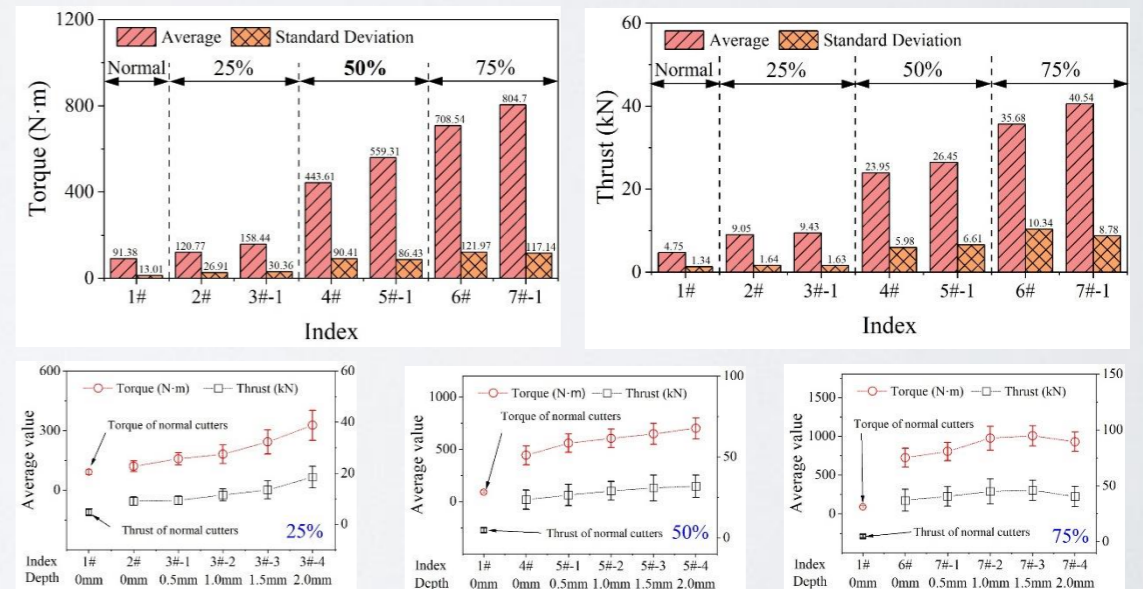
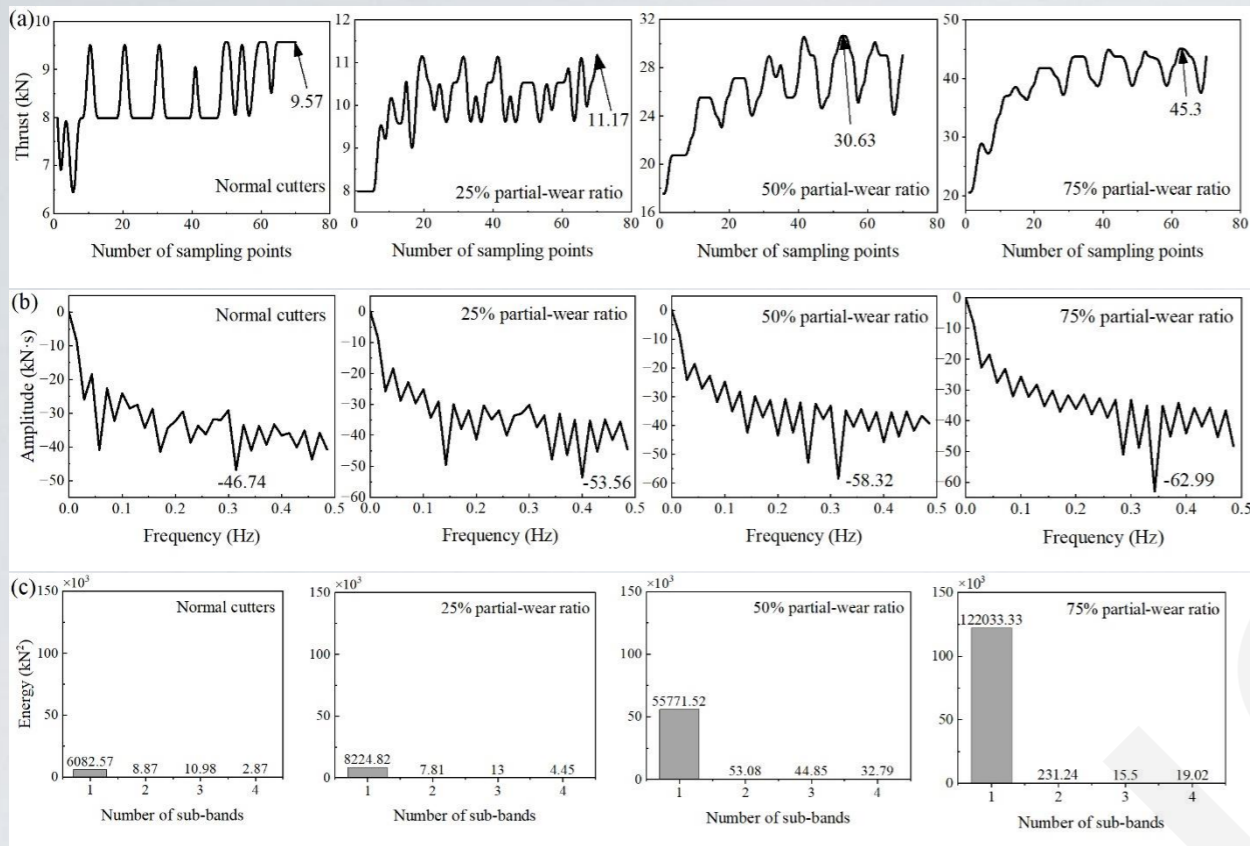
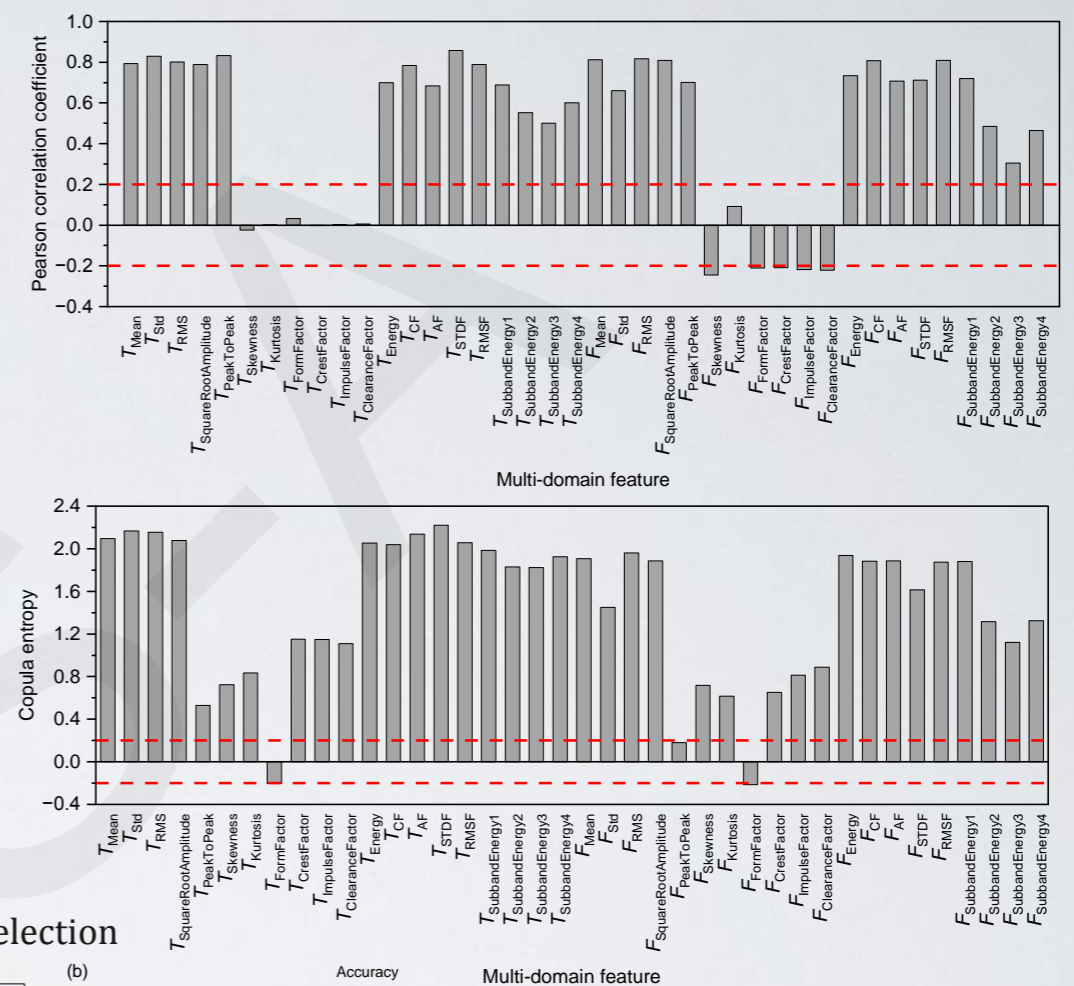

Figure 1. Experiment and analysis, a) reduced-scale shield-test rig for experiments on partial wear, b) experiment procedure and test groups, c) results and analysis: statistical features of thrust and torque, impact of partial-wear depth

### (a) Multi-domain feature extraction



### (b) Feature-correlation analysis



### (c) Specific structure of the model

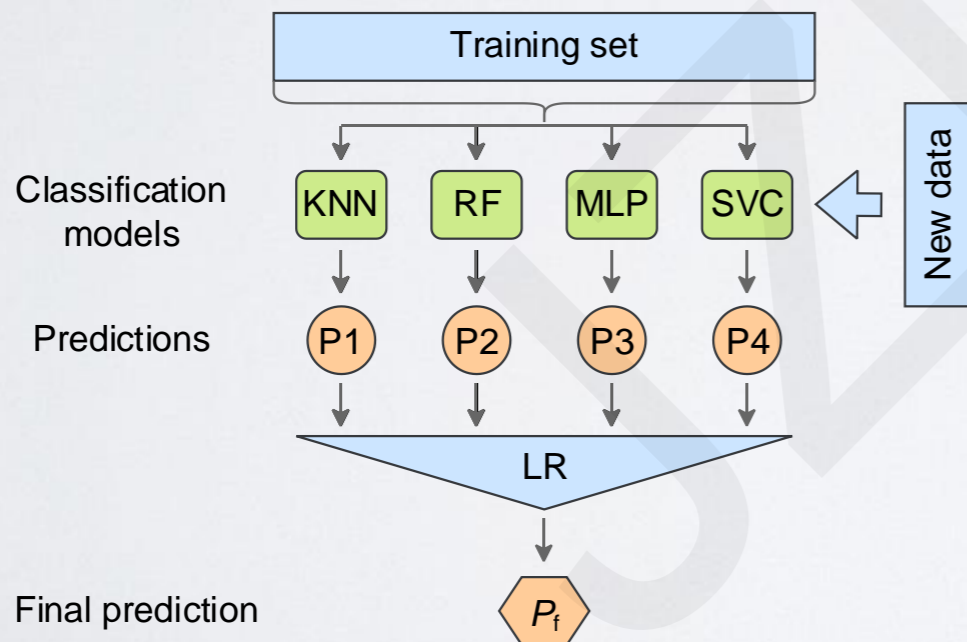

### Hyperparameters selection

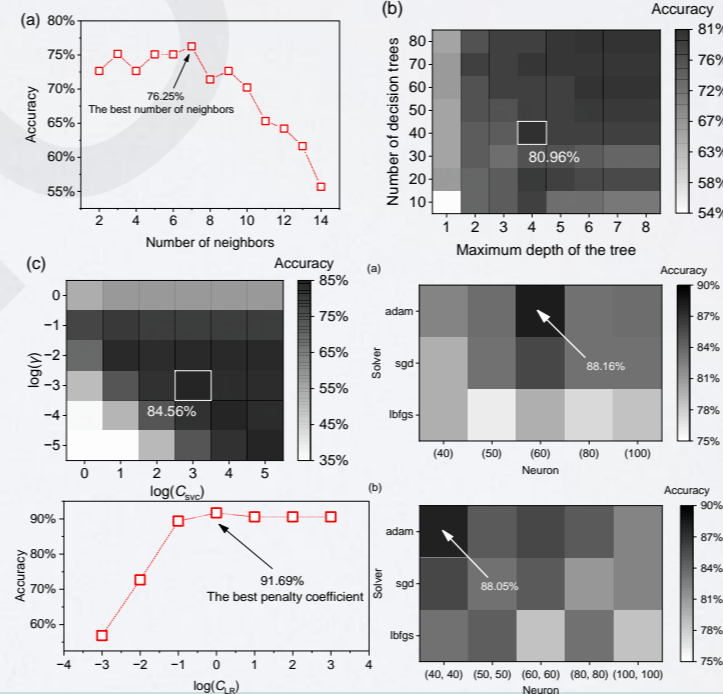

### ROC curves

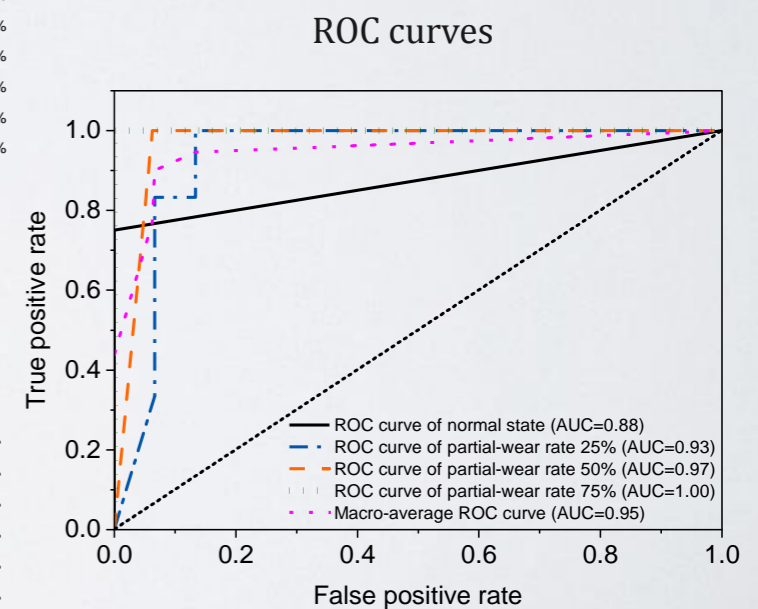

**Figure 2. Partial-wear-ratio discrimination method and validation, a) multi-domain feature spectrum: time-domain waveforms, spectrograms, sub-band energy diagrams; b) relationship between multi-domain features and partial-wear ratio, c) partial-wear-ratio discrimination model**

# Perspectives and Research Priorities

## Research Priorities:

- Experiments on normal disc cutters and disc cutters with a certain proportion of partial wear and different partial-wear
- Variation in tunneling parameters
- Accurate method for discriminating disc-cutter partial-wear ratio

Abnormal disc cutter wear significantly increases tunneling torque and thrust through altered rock-cutter interactions (rolling-to-sliding transitions) and geometric profile changes. The partial-wear ratio exerts greater influence on parameter magnitudes than wear depth, with higher ratios causing substantial torque/thrust increases while depth variations yield minimal effects under constant ratios. Wear depth minimally affects cyclic fluctuations, potentially improving stability through expanded contact areas. Multidimensional feature analysis reveals linear/nonlinear correlations between time-frequency/higher-order statistical features and wear progression. The PRDM model outperforms conventional algorithms in wear ratio discrimination, demonstrating robust accuracy across operational conditions via ROC validation.