

Accuracy allocation method for five-axis machine tools based on geometric error cost sensitivity prioritizing tool direction deviation

Xiaojian LIU, Ao JIAO, Yang WANG, Guodong YI, Xiangyu GAO, Xiaochen ZHANG, Yiming ZHANG, Yangjian JI, Shuyou ZHANG, Jianrong TAN

Cite this as: Xiaojian LIU, Ao JIAO, Yang WANG, Guodong YI, Xiangyu GAO, Xiaochen ZHANG, Yiming ZHANG, Yangjian JI, Shuyou ZHANG, Jianrong TAN, 2025. Accuracy allocation method for five-axis machine tools based on geometric error cost sensitivity prioritizing tool direction deviation. *Journal of Zhejiang University-SCIENCE A (Applied Physics & Engineering)*, 26(7):635-651.

<https://doi.org/10.1631/jzus.A2400287>

Accuracy Allocation

Accuracy allocation

Break down the accuracy requirements of the entire machine into individual error sources.

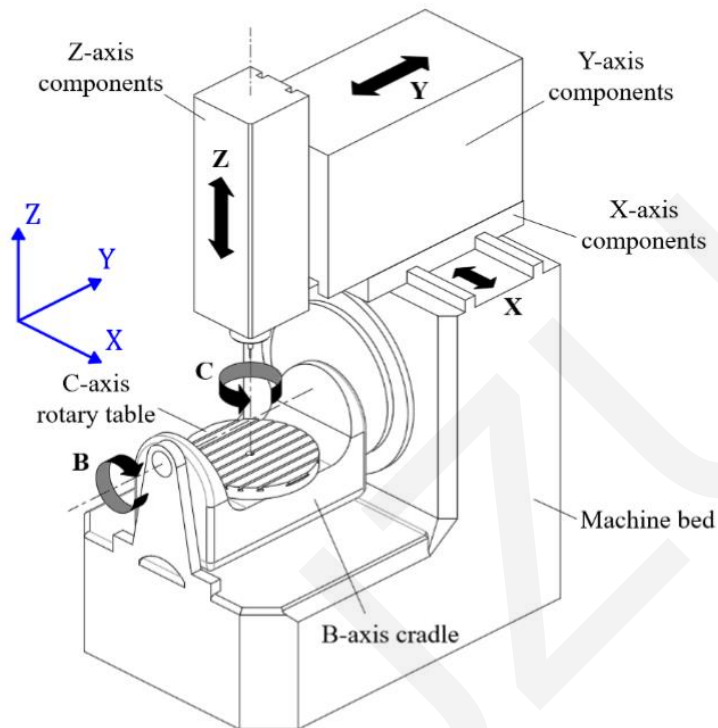

High Precision

Manufacturing Costs

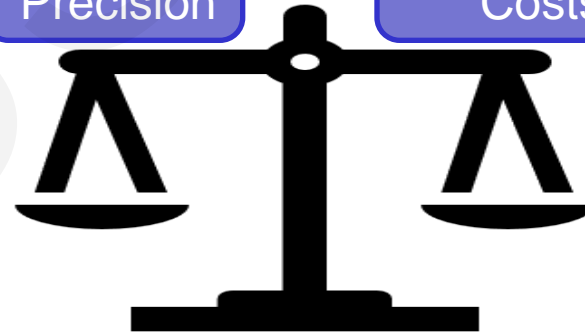

Key challenge: Finding the optimal balance between meeting strict accuracy requirements and controlling high manufacturing costs.

Geometric Error

Geometric error source

Linear axes

Rotary axes

Geometric Errors	
X-axis	$\delta_{XX}, \delta_{YX}, \delta_{ZX}, \varepsilon_{XX}, \varepsilon_{YX}, \varepsilon_{ZX}$
Y-axis	$\delta_{XY}, \delta_{YY}, \delta_{ZY}, \varepsilon_{XY}, \varepsilon_{YY}, \varepsilon_{ZY}$
PDGEs	Z-axis $\delta_{XZ}, \delta_{YZ}, \delta_{ZZ}, \varepsilon_{XZ}, \varepsilon_{YZ}, \varepsilon_{ZZ}$
B-axis	$\delta_{XB}, \delta_{YB}, \delta_{ZB}, \varepsilon_{XB}, \varepsilon_{YB}, \varepsilon_{ZB}$
C-axis	$\delta_{XC}, \delta_{YC}, \delta_{ZC}, \varepsilon_{XC}, \varepsilon_{YC}, \varepsilon_{ZC}$
PIGEs	$S_{XY}, S_{YZ}, S_{XZ}, S_{BX}, S_{BZ}, S_{CX}, S_{CY}, o_{BX}, o_{BZ}, o_{CX}, o_{CY}$

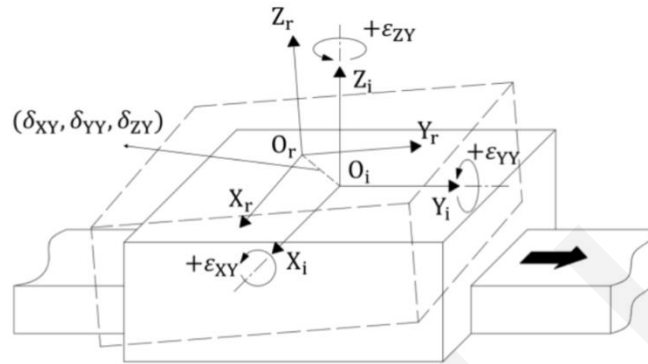

(a) Y-axis PDGEs

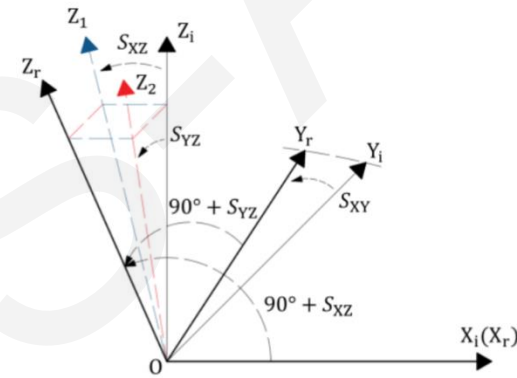

(b) Linear axis PIGEs

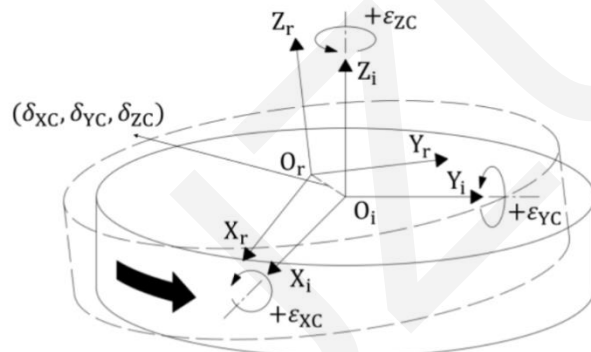

(c) C-axis PDGEs

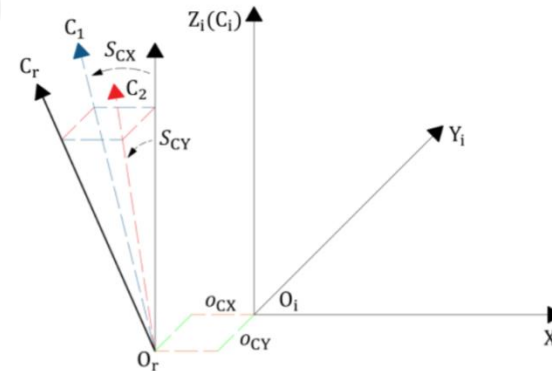

(d) C-axis PIGEs

- (a) Linear axes Y-axes position-dependent geometric errors (PDGEs).
- (b) Linear axes Y-axes position-independent geometric errors (PIGEs)
- (c) Rotary axes C-axes PDGEs
- (d) Rotary axes C-axes PIGEs

Error Modeling and Cost Sensitivity Analysis

Geometric error modeling of a BC-type five-axis machine tool

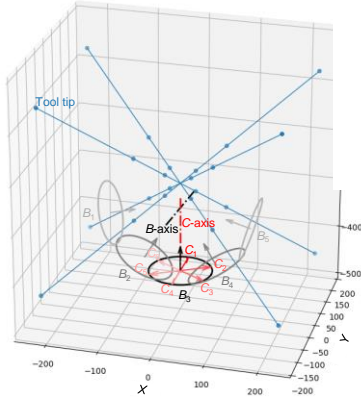

Volumetric sampling points from a combination of the linear and rotary axes

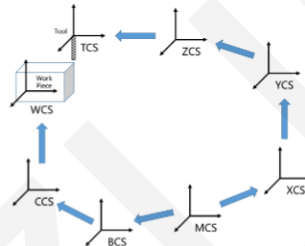
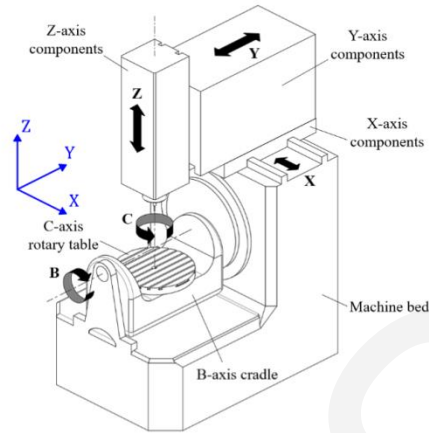

$${}^T T^r = \begin{pmatrix} 1 & 0 & 0 & o_{BX} \\ 0 & 1 & 0 & 0 \\ 0 & 0 & 1 & o_{BZ} - 360 \\ 0 & 0 & 0 & 1 \end{pmatrix} \begin{pmatrix} 1 & -S_{BX} & 0 & 0 \\ S_{BX} & 1 & S_{BZ} & 0 \\ 0 & -S_{BZ} & 1 & 0 \\ 0 & 0 & 0 & 1 \end{pmatrix} \begin{pmatrix} \cos B & 0 & \sin B & 0 \\ 0 & 1 & 0 & 0 \\ -\sin B & 0 & \cos B & 0 \\ 0 & 0 & 0 & 1 \end{pmatrix}$$

$$\begin{pmatrix} 1 & -\varepsilon_{ZB} & \varepsilon_{YB} & \delta_{XB} \\ z_B & 1 & -\varepsilon_{XB} & \delta_{YB} \\ y_B & \varepsilon_{XB} & 1 & \delta_{ZB} \\ 0 & 0 & 0 & 1 \end{pmatrix} \begin{pmatrix} 1 & 0 & 0 & o_{CX} \\ 0 & 1 & 0 & o_{CY} \\ 0 & 0 & 1 & -140 \\ 0 & 0 & 0 & 1 \end{pmatrix} \begin{pmatrix} 1 & 0 & -S_{CX} & 0 \\ 0 & 1 & -S_{CY} & 0 \\ S_{CX} & S_{CY} & 1 & 0 \\ 0 & 0 & 0 & 1 \end{pmatrix} \begin{pmatrix} \cos C & -\sin C & 0 & 0 \\ \sin C & \cos C & 0 & 0 \\ 0 & 0 & 1 & 0 \\ 0 & 0 & 0 & 1 \end{pmatrix}$$

$$\begin{pmatrix} 1 & -\varepsilon_{ZC} & \varepsilon_{YC} & \delta_{XC} \\ \varepsilon_{ZC} & 1 & -\varepsilon_{XC} & \delta_{YC} \\ -\varepsilon_{YC} & \varepsilon_{XC} & 1 & \delta_{ZC} \\ 0 & 0 & 0 & 1 \end{pmatrix}^{-1} \begin{pmatrix} 1 & 0 & 0 & X \\ 0 & 1 & 0 & 0 \\ 0 & 0 & 1 & 0 \\ 0 & 0 & 0 & 1 \end{pmatrix} \begin{pmatrix} 1 & -\varepsilon_{ZX} & \varepsilon_{YX} & \delta_{XX} \\ \varepsilon_{ZX} & 1 & -\varepsilon_{XX} & \delta_{YX} \\ -\varepsilon_{YX} & \varepsilon_{XX} & 1 & \delta_{ZX} \\ 0 & 0 & 0 & 1 \end{pmatrix}$$

$$\begin{pmatrix} 1 & 0 & 0 & -Y \times S_{XY} \\ 0 & 1 & 0 & Y \\ 0 & 0 & 1 & 0 \\ 0 & 0 & 0 & 1 \end{pmatrix} \begin{pmatrix} 1 & -S_{XY} & 0 & 0 \\ S_{XY} & 1 & 0 & 0 \\ 0 & 0 & 1 & 0 \\ 0 & 0 & 0 & 1 \end{pmatrix} \begin{pmatrix} 1 & -\varepsilon_{ZY} & \varepsilon_{YY} & \delta_{XY} \\ \varepsilon_{ZY} & 1 & -\varepsilon_{XY} & \delta_{YY} \\ -\varepsilon_{YY} & \varepsilon_{XY} & 1 & \delta_{ZY} \\ 0 & 0 & 0 & 1 \end{pmatrix}$$

$$\begin{pmatrix} 1 & 0 & 0 & -(Z + 360) \times S_{XZ} \\ 0 & 1 & 0 & -(Z + 360) \times S_{YZ} \\ 0 & 0 & 1 & Z \\ 0 & 0 & 0 & 1 \end{pmatrix} \begin{pmatrix} 1 & 0 & -S_{XZ} & 0 \\ 0 & 1 & -S_{YZ} & 0 \\ S_{XZ} & S_{YZ} & 1 & 0 \\ 0 & 0 & 0 & 1 \end{pmatrix} \begin{pmatrix} 1 & -\varepsilon_{ZZ} & \varepsilon_{YZ} & \delta_{XZ} \\ \varepsilon_{ZZ} & 1 & -\varepsilon_{XZ} & \delta_{YZ} \\ -\varepsilon_{YZ} & \varepsilon_{XZ} & 1 & \delta_{ZZ} \\ 0 & 0 & 0 & 1 \end{pmatrix}$$

Geometric error cost sensitivity

Error sensitivity Sobol index: $S_i^T = \frac{1}{4nm_1m_2} \sum_{j=0}^{4nm_1m_2} P_j S_i$

Geometric error accuracy cost: $C_{total} = \sum_{i=1}^{41} C(T_i) = \sum_{i=1}^{41} \frac{k_i}{T_i^2}$

Cost impact factor: $\omega_i = \frac{S_i^T}{C_i}$

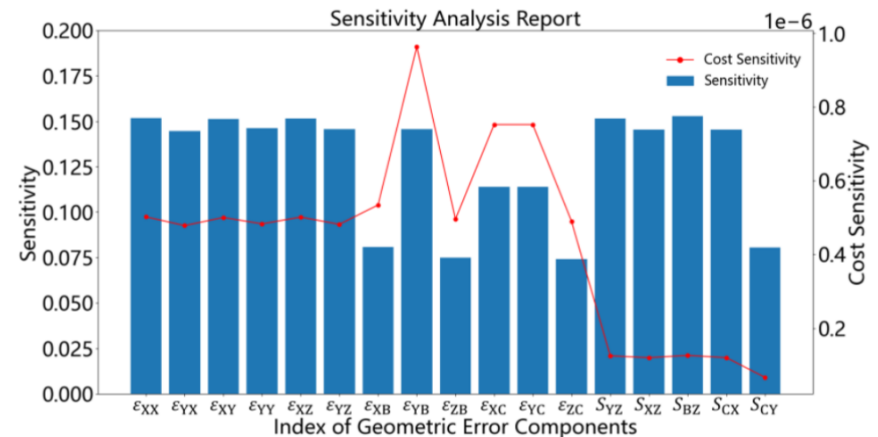

Prioritize Tool Direction Allocation Strategy

In precision machining operations such as side milling and drilling, even slight deviations in the tool direction can significantly affect the geometric accuracy of the machined surface, including contour accuracy and perpendicularity.

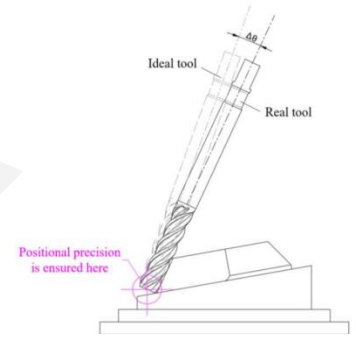

A two-step accuracy allocation method:
 First adjusting error components that affect tool direction deviation, and then adjusting the remaining error components

Tool direction accuracy allocation

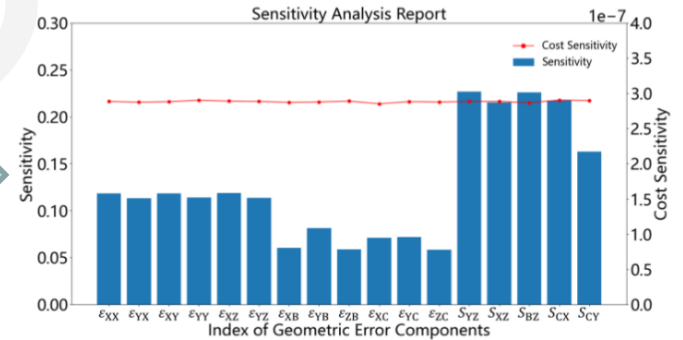
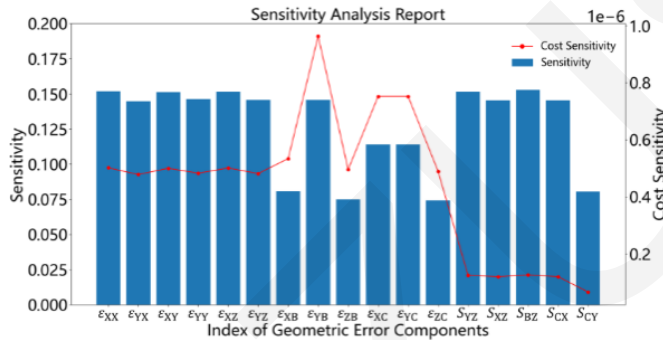

Positional accuracy allocation

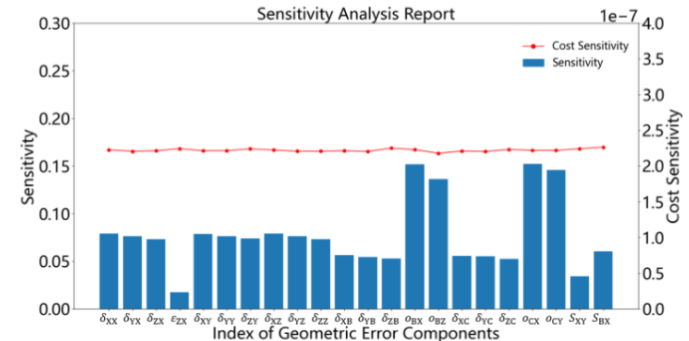
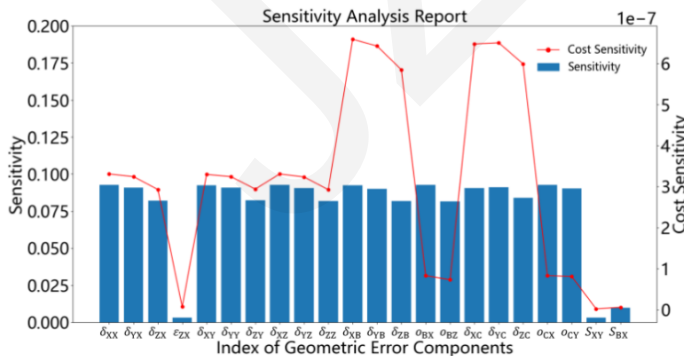

Comparison Of Results

The processed allocation scheme described in this paper is almost identical to that achieved by uniform allocation scheme.

Positional deviation

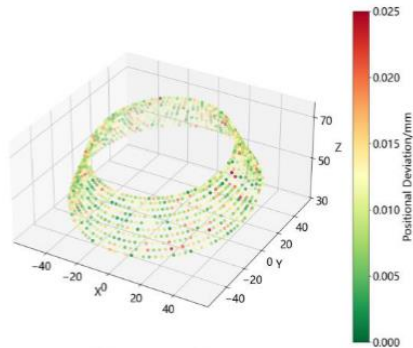

(a) Proposed allocation scheme

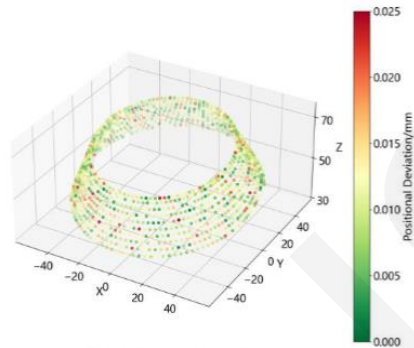

(b) Uniform allocation scheme

Direction deviation

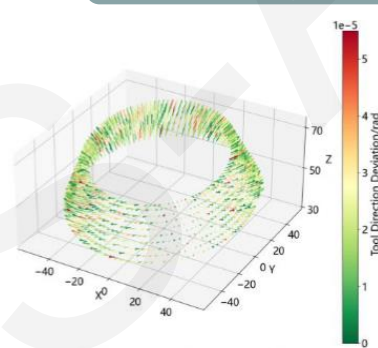

(a) Proposed allocation scheme

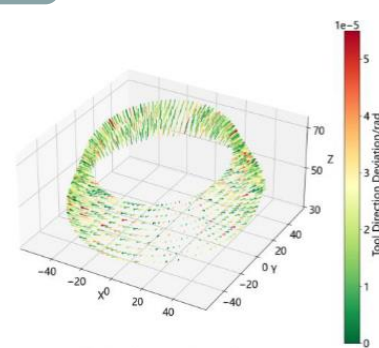

(b) Uniform allocation scheme

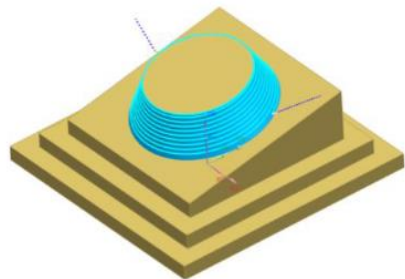

Simulation on machining an inclined conical workpiece

	Uniform Allocation Scheme	Allocation Scheme by Our Proposed Method	Improvement Rate
Mean Positional Deviation/mm	0.0108	0.0107	-0.93%
Variance of Positional Deviation/mm²	2.04×10^{-5}	1.94×10^{-5}	/
Frequency of $\Delta P \leq 20\mu\text{m}$	0.9688	0.9696	+0.08%
Mean Tool direction deviation/rad	2.00×10^{-5}	1.99×10^{-5}	-0.50%
Variance of Tool direction deviation/rad²	1.08×10^{-10}	1.15×10^{-10}	/
Frequency of $\Delta V \leq 40\mu\text{rad}$	0.9584	0.9592	+0.08%
Estimated Cost	20,997,862	15,163,102	-27.8%

Under the same processing accuracy conditions, the proposed allocation scheme can significantly reduce the total estimated geometric error cost by 27.8%.

Conclusions

- This paper proposes a novel accuracy allocation method for five-axis machine tool that prioritizes tool direction deviation and combines it with cost sensitivity.
- This method has been verified to significantly reduce manufacturing costs (27.8% in this case) while maintaining the same high level of precision.
- It provides a strong theoretical basis and practical tools for the economical and reasonable allocation of accuracy in the design stage of multi-axis machine tools.