

Near-term applications of superconducting digital quantum simulation

Yunyan YAO, Zhen WANG

Cite this as: Yunyan YAO, Zhen WANG, 2024. Near-term applications of superconducting digital quantum simulation. *Journal of Zhejiang University-SCIENCE A (Applied Physics & Engineering)*, 25(10):854-876. <https://doi.org/10.1631/jzus.A2400397>

Digital quantum simulation (DQS)

- Schematic of DQS

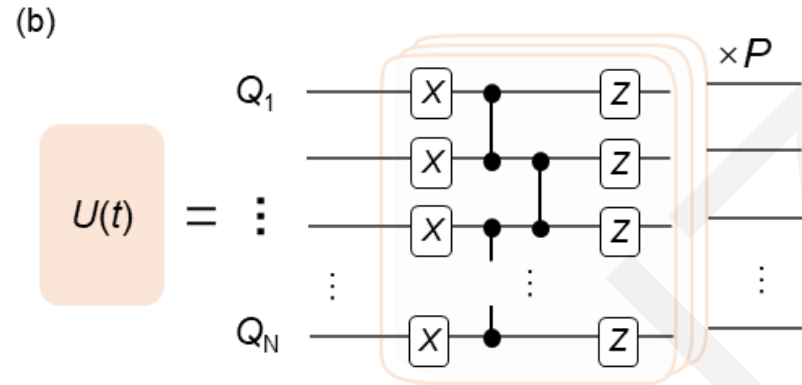
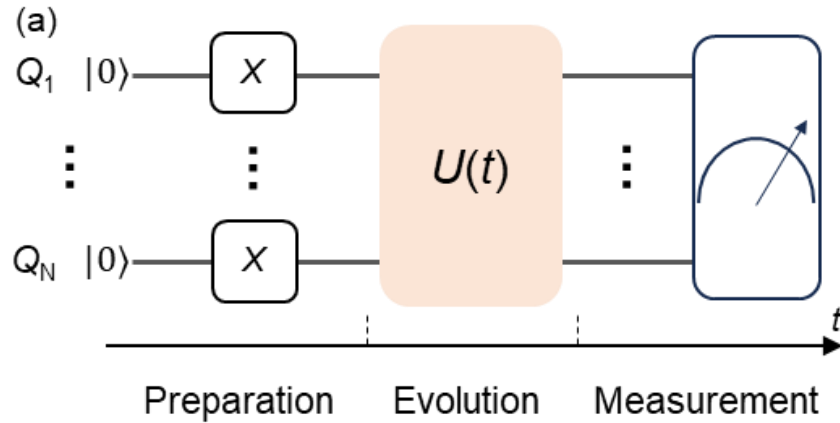

Suzuki-Lie-Trotter decomposition:

$$U(\Delta t) = e^{-\frac{i}{\hbar} \sum_i H_i \Delta t}$$

- Typical single-qubit gates

Gate	Circuit	$R(\theta = \pi)$	Bloch sphere ($\theta = \pi$)
I		$\begin{bmatrix} 1 & 0 \\ 0 & 1 \end{bmatrix}$	
X		$\begin{bmatrix} 0 & 1 \\ 1 & 0 \end{bmatrix}$	
Y		$\begin{bmatrix} 0 & -i \\ i & 0 \end{bmatrix}$	
Z		$\begin{bmatrix} 1 & 0 \\ 0 & -1 \end{bmatrix}$	
H		$\frac{1}{\sqrt{2}} \begin{bmatrix} 1 & 1 \\ 1 & -1 \end{bmatrix}$	

- Typical two-qubit gates

Gate	Circuit	$R(\theta = \pi)$	Levels structure
iSWAP		$\begin{bmatrix} 1 & 0 & 0 & 0 \\ 0 & 0 & -i & 0 \\ 0 & -i & 0 & 0 \\ 0 & 0 & 0 & 1 \end{bmatrix}$	
CPHASE		$\begin{bmatrix} 1 & 0 & 0 & 0 \\ 0 & 1 & 0 & 0 \\ 0 & 0 & 1 & 0 \\ 0 & 0 & 0 & -1 \end{bmatrix}$	
CNOT		$\begin{bmatrix} 1 & 0 & 0 & 0 \\ 0 & 1 & 0 & 0 \\ 0 & 0 & 0 & 1 \\ 0 & 0 & 1 & 0 \end{bmatrix}$	

Overview of near-term applications based on DQS

- Nonequilibrium many-body physics
- Topological quantum matters

- Quantum approximation optimization algorithm

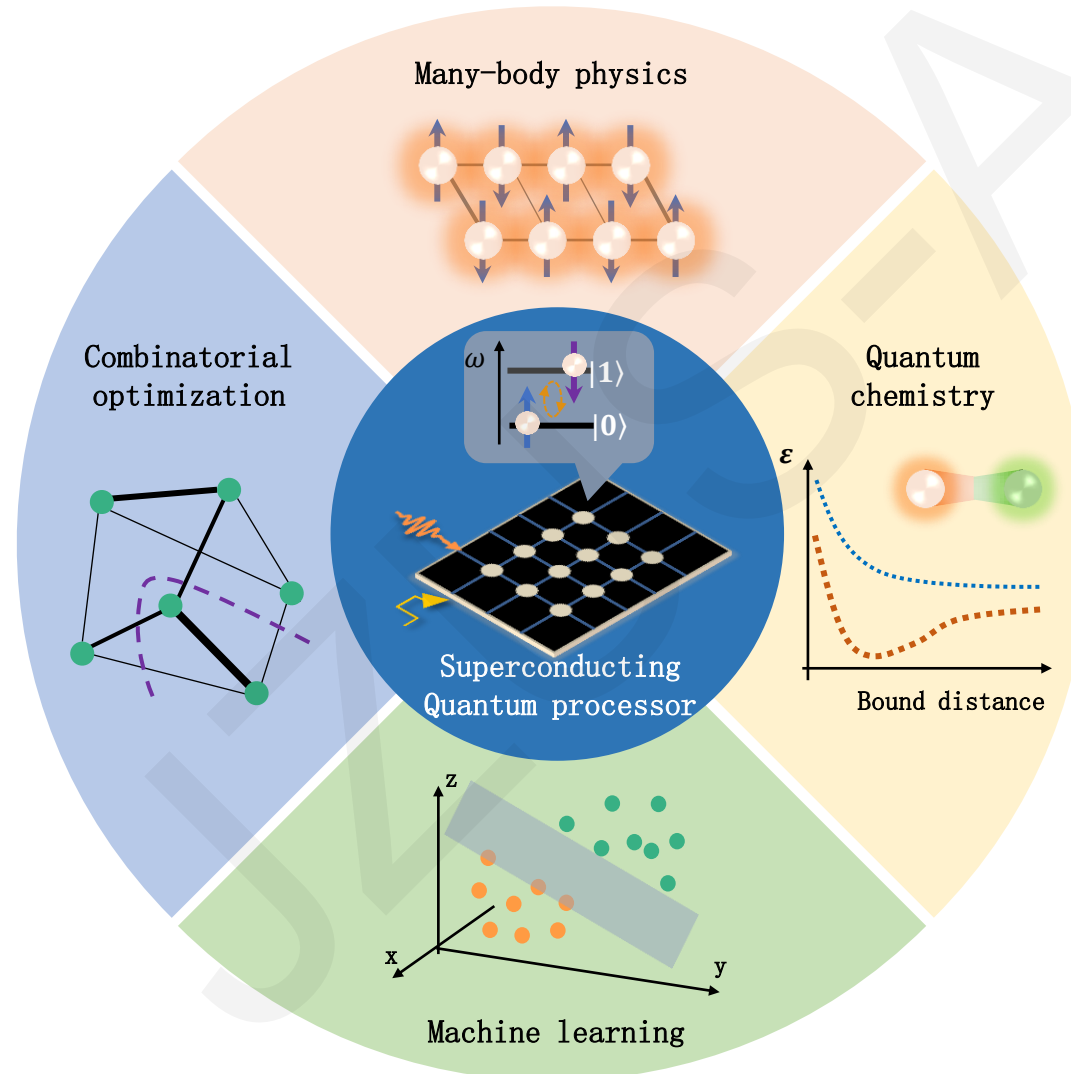

- Variational quantum eigensolver
- Quantum phase estimation
- Quantum Monte Carlo

- Quantum neural network
- Quantum kernel estimation
- Quantum generation adversarial network

Challenges for superconducting digital quantum simulation

➤ Performance of superconducting processors

- Prolong coherence time of transmon qubit ($\sim 100 \mu\text{s}$)
- High-fidelity single- and two-qubit gates (> 0.999 and > 0.995 , respectively)

➤ Quantum error correction (QEC)

- Surface code
- Bosonic code

➤ Digital-analog quantum simulation

- Quantum advantages without QEC
- Decomposition algorithm

Conclusions

- Based on the superconducting digital quantum simulation, various applications were implemented:
 - ✓ In quantum chemistry, the ground state estimation of molecules from H_2 to complex F_2 under the precision of chemistry accuracy were achieved;
 - ✓ High-precision simulations of emerging quantum matters, such as discrete time crystal;
 - ✓ Many proof-of-principle demonstration of quantum combinatorial optimization and machine learning.
- These applications are still accessible to classical computers. By tackling the challenges of digital quantum simulation and superconducting qubits, superconducting digital quantum simulation is believed to hold the anticipated future in implementing quantum advantages.