

Axial compression performance and confinement mechanism of concrete-filled corrugated steel tubular columns

Jiaming ZHANG, Chaoqun YU, Genshu TONG, Jingzhong TONG

Cite this as: Jiaming ZHANG, Chaoqun YU, Genshu TONG, Jingzhong TONG, 2026. Axial compression performance and confinement mechanism of concrete-filled corrugated steel tubular columns. *Journal of Zhejiang University-SCIENCE A*, 27(2):155-168. <https://doi.org/10.1631/jzus.A2500090>

Corrugated Steel Plate Structural System

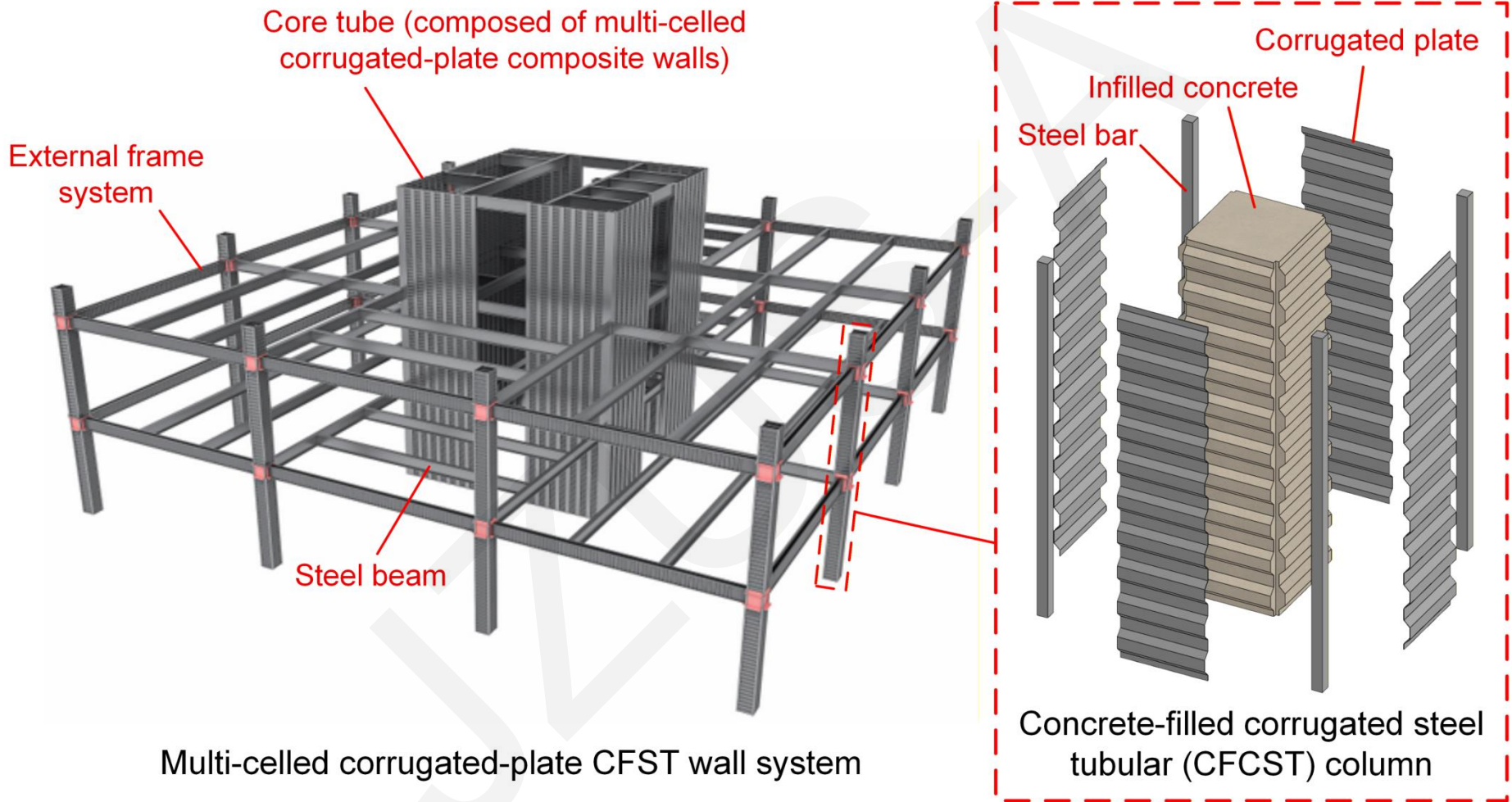

Based on the mechanical advantages of corrugated steel plates, a novel prefabricated composite structural system is proposed.

Theoretical Analysis Framework

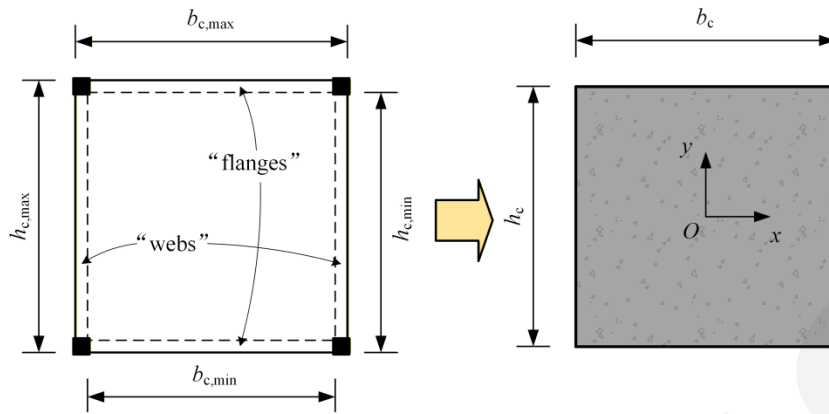

Cross-section simplification

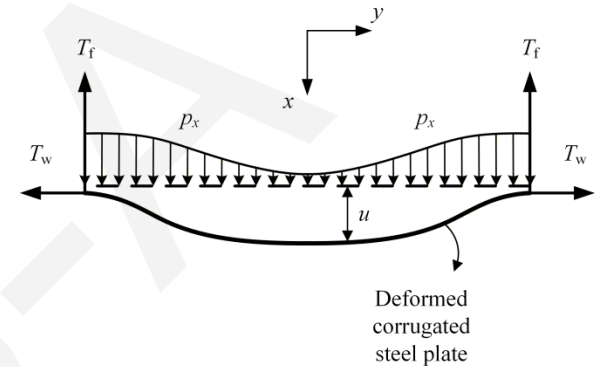

Deformed corrugated steel plate

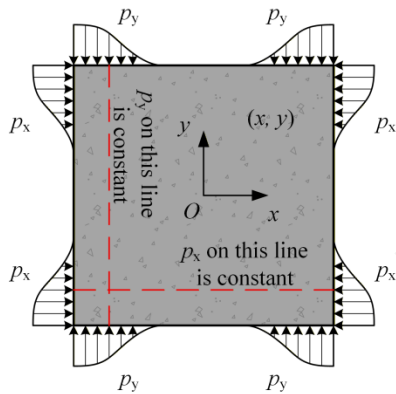

Calculation for lateral stress and deformation

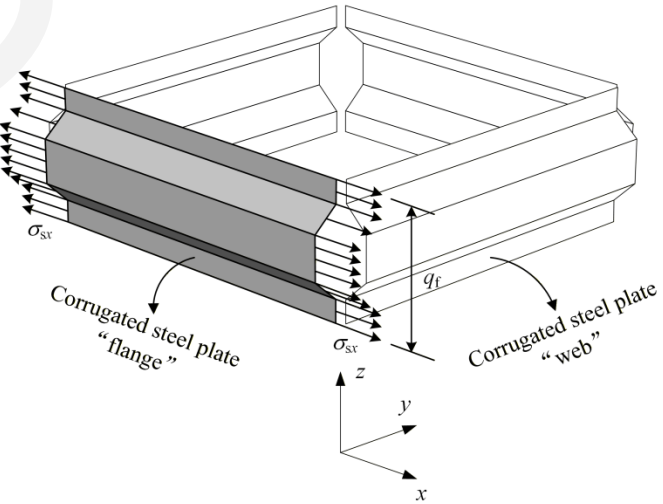
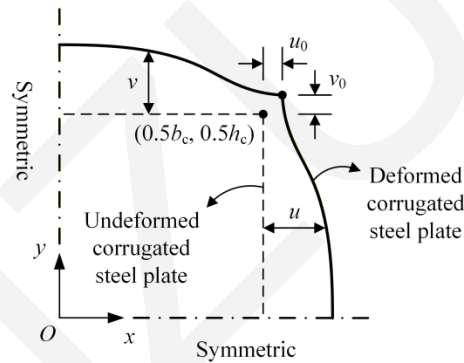

Deformation compatibility and force equilibrium

Theoretical analysis is conducted through section simplification and compatibility conditions.

Results and Discussion

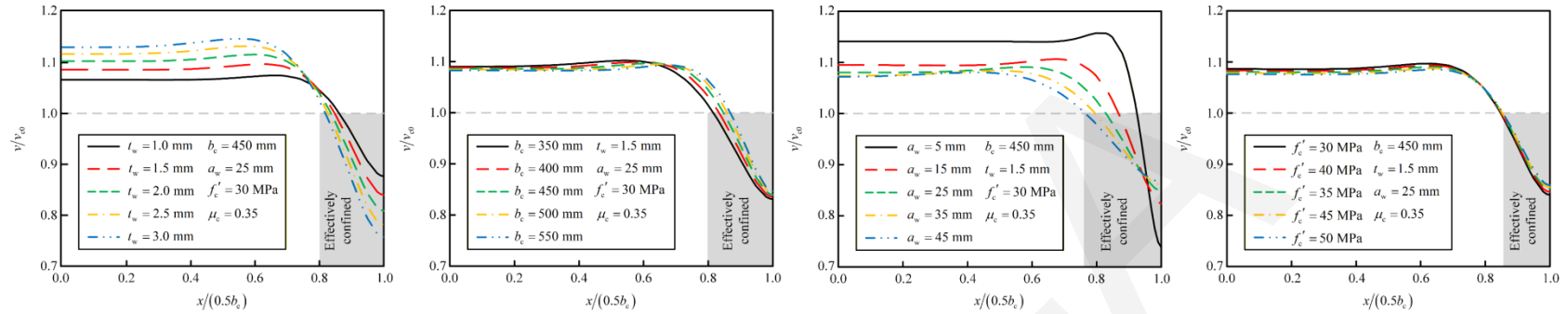

Lateral displacement distribution with different parameters

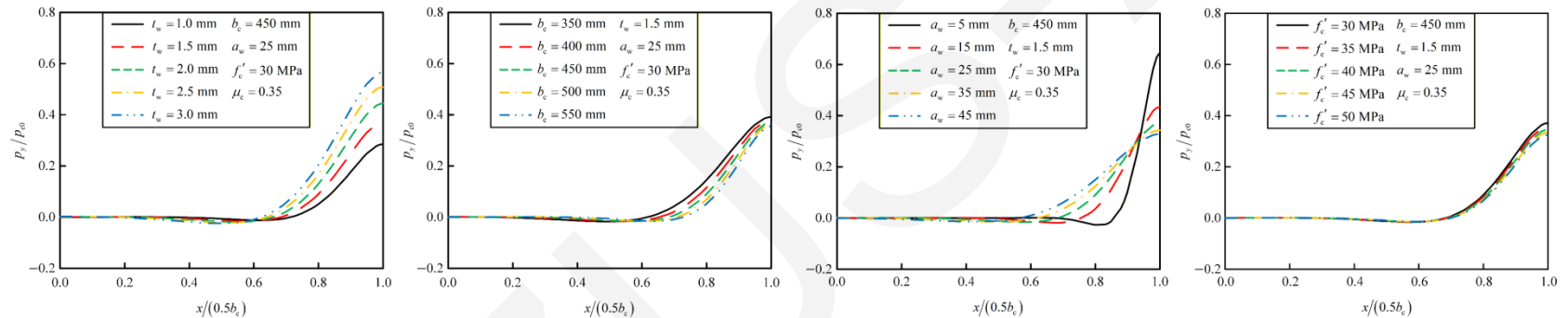

Lateral stress distribution with different parameters

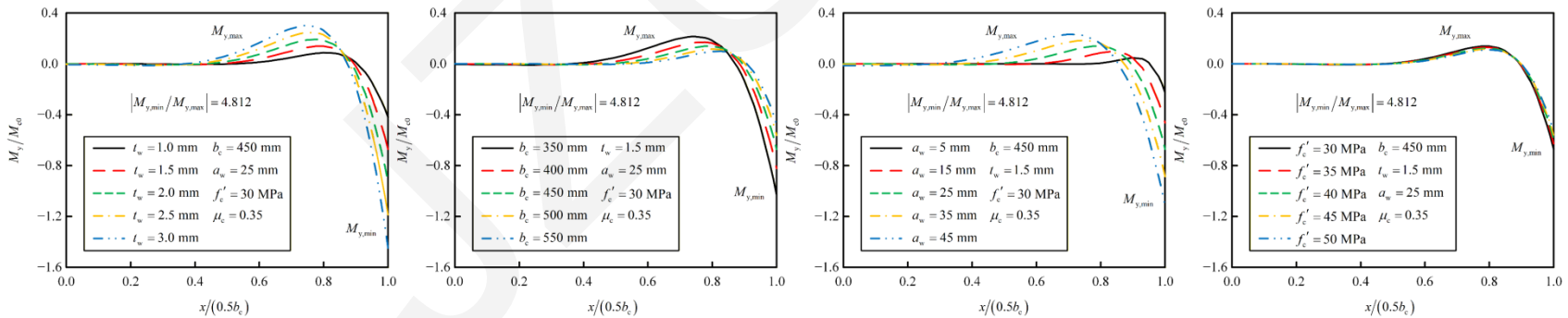

Lateral moment distribution with different parameters

Exact solutions for lateral displacement, stress, and moment are derived, followed by parametric analysis.

Plastic Analysis and Design Method

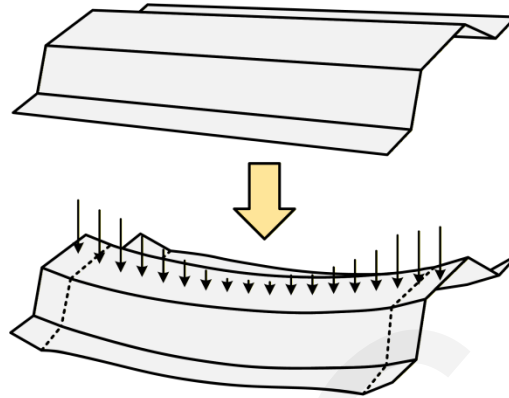
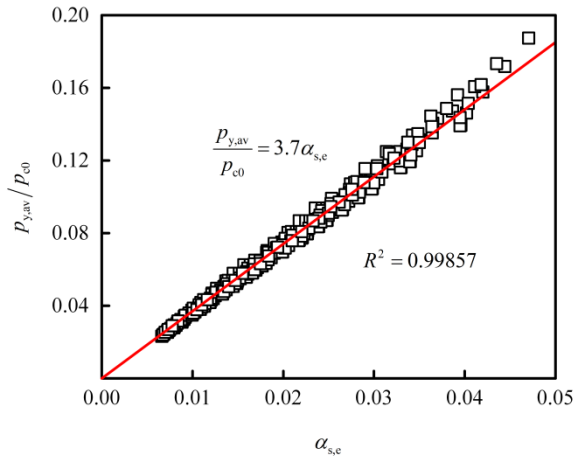

Plastic deformation of the corrugated plate

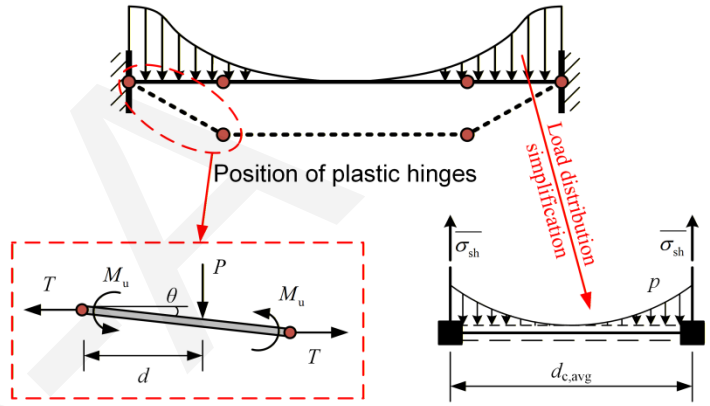

Equilibrium of plastic limit states

Simplified distribution of lateral pressure

Formula for lateral stress

Plastic deformation mechanism analysis

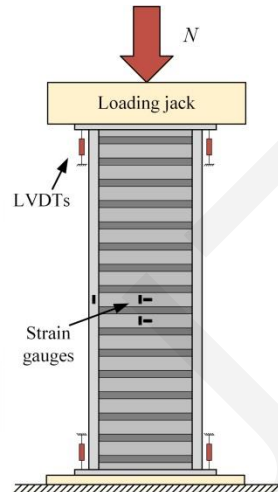

Experimental test

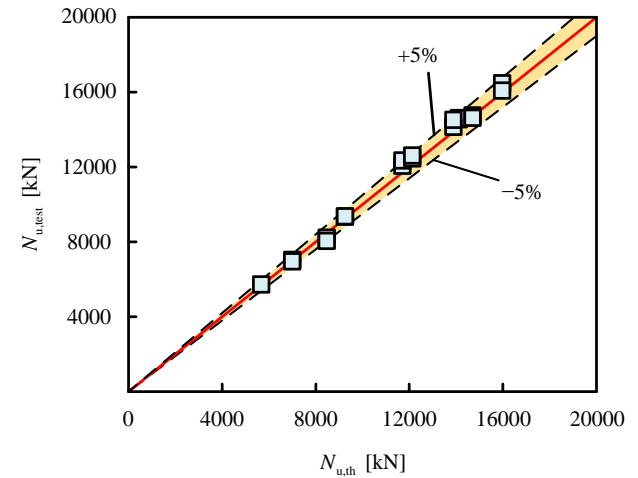
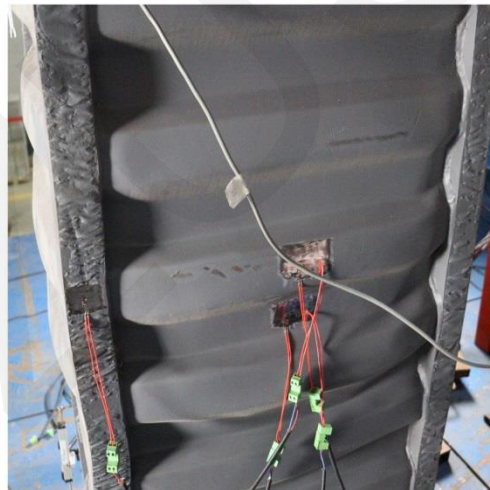

Design formula validation

A simplified lateral stress formula, plastic mechanism, and design formula for axial capacity are proposed and validated.

Conclusions

- In this study, **a theoretical model** was established to investigate the **confinement behavior** of concrete-filled corrugated steel tubular (CFCST) columns. **Exact solutions** for lateral displacement, lateral stress, and bending moment distributions were derived, revealing that the confinement effect is strong at boundary regions and weak at the mid-span. **A simplified lateral stress formula** was proposed, the plastic deformation mechanism was systematically analyzed, and **a design formula** for axial load-bearing capacity was developed and validated against experimental results, with deviations within **$\pm 5\%$** .