

Cite this as: Weiguang SU, Dawei WANG, Siegfried YEBOAH, Jinshen WANG, Chonghai XU, Li WANG. Microencapsulation and characterization of controlled-release intestinal drugs: a critical review. *Journal of Zhejiang University-SCIENCE B*, 2026, 27(4):321-342. <https://doi.org/10.1631/jzus.B2400617>

Microencapsulation and characterization of controlled-release intestinal drugs: a critical review

Key words: Oral drug; Controlled release; Microencapsulated intestinal drug; Microencapsulation method; Response mechanism

Research Summary

This review mainly focused on the preparation, release mechanism, and evaluation strategies of microencapsulated intestinal drugs (MeIDs), and summarized their key roles in the following aspects:

- Preparation Techniques
- Release Mechanisms
- Evaluation Strategies

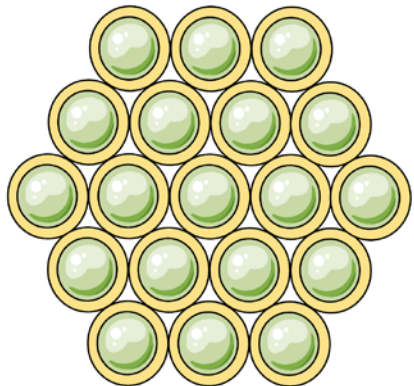
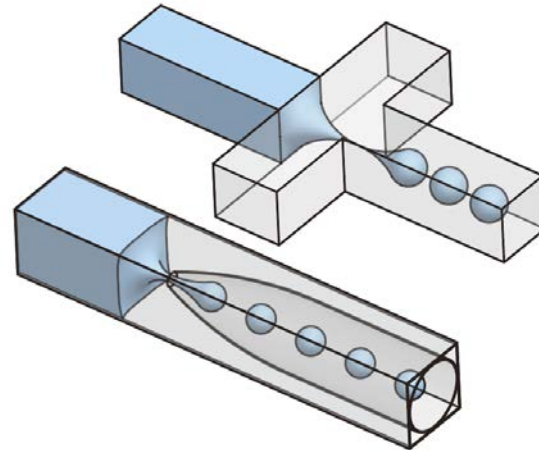
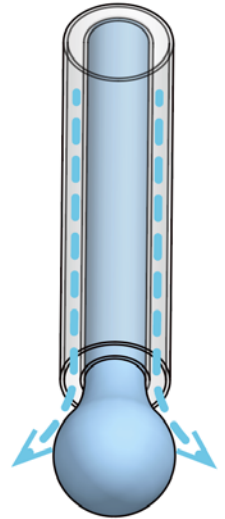

Innovation points

- **Introduction** of current microencapsulation strategies for oral intestinal drug delivery, covering emulsion preparation, microencapsulation, and material selection.
- **Summary** of recent advances in evaluating microencapsulated drug systems, including biocompatibility testing, release kinetics analysis, and in vivo pharmacodynamic studies.
- **Emphasis** on the synergistic use of coating methods, micro/nano-carriers, and absorption enhancers to enhance formulation stability, bioavailability, and targeted delivery efficiency.

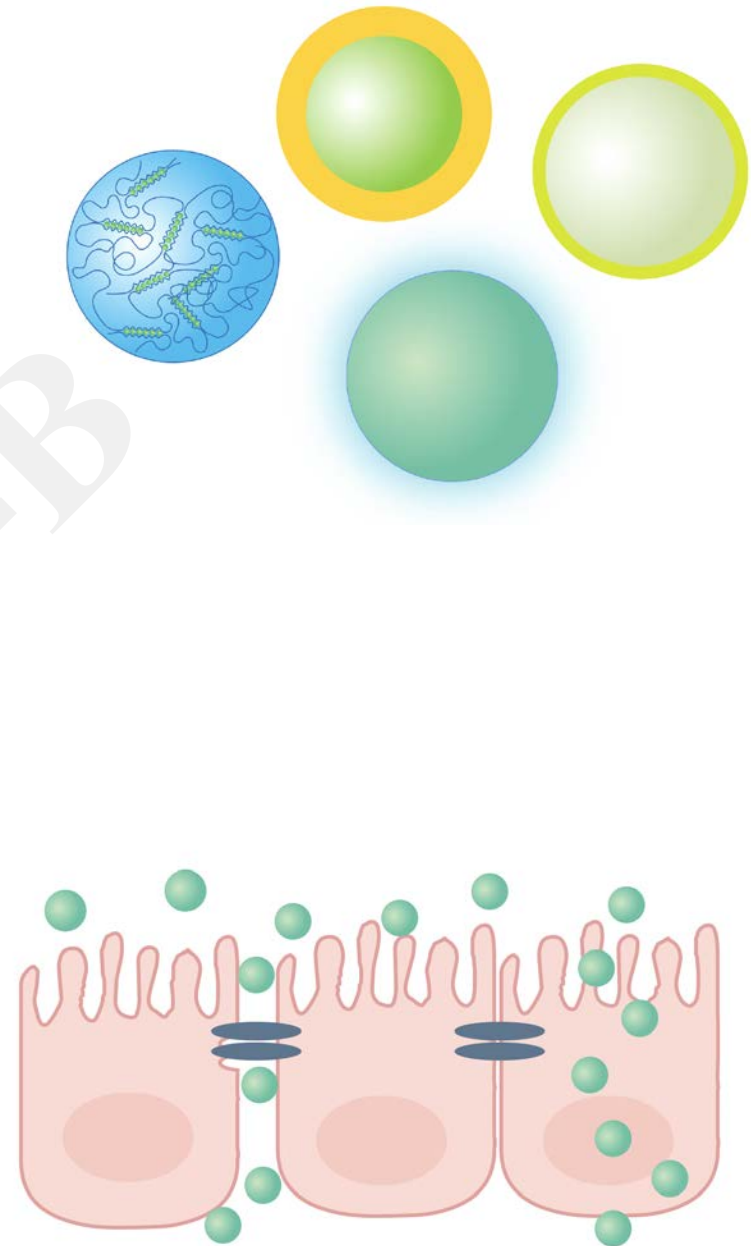

Innovation points

A series of comprehensive tables were generated to summarize recent progress in microencapsulation strategies for oral intestinal drug delivery.

Table 1 | Summary and comparison of various droplet dispersion methods.

Table 2 | Preparation methods and characteristics of MeID.

Table 3 | Mathematic models for drug release kinetics.