

A multimode digital controller IC for flyback converter with high accuracy primary-side feedback

高精度原边反馈型反激变换器的 多模式数字控制芯片

Citation: Jian-ping Qiu, Le-nian He, Yu-lin Wang, 2013. A multimode digital controller IC for flyback converter with high accuracy primary-side feedback. *Journal of Zhejiang University-Science C (Computers & Electronics)*, 14(8):652-662. [doi:10.1631/jzus.C1200344]

- Traditionally, analog control is used in the flyback converter. However, digital control, which is a thriving control, is bringing more advantages, including insensitivity to parameter variation, programmability, and even fewer external components
- In a traditional flyback converter, an opto-coupler is used to feed back the output voltage without breaking the isolation between input and output. However, the current transfer ratio of the opto-coupler varies with temperature and time. The primary-side feedback could eliminate the need of the opto-coupler, but the feedback error will be a serious problem
- Considering the widespread applications of flyback converters in adapter chargers, it is necessary to design converters that can output both constant voltage (CV) and constant current (CC)

- This paper presents a multimode (PWM/PFM/CC) digital controller for the flyback converter with a novel primary-side sensing technology which achieves high accuracy

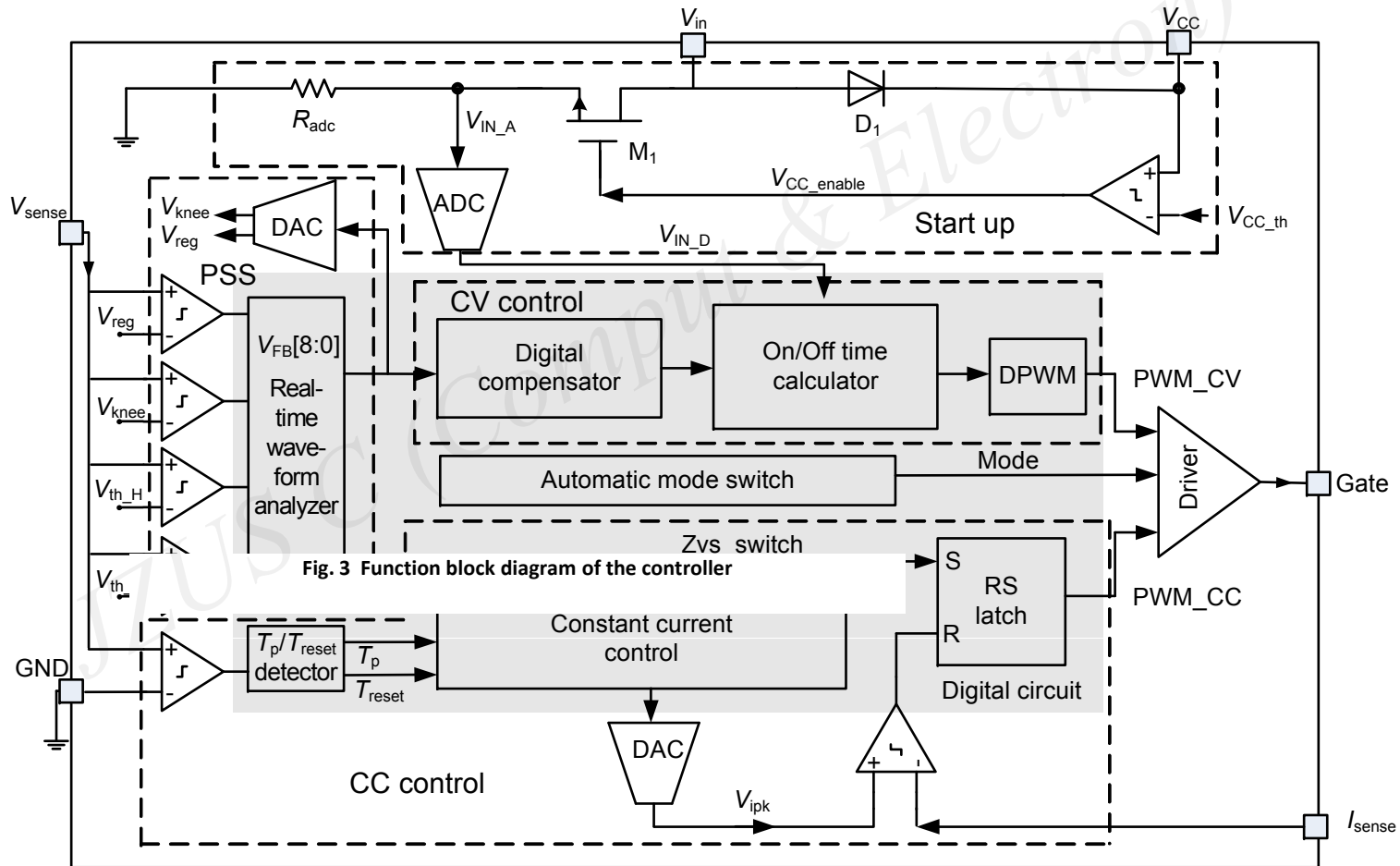

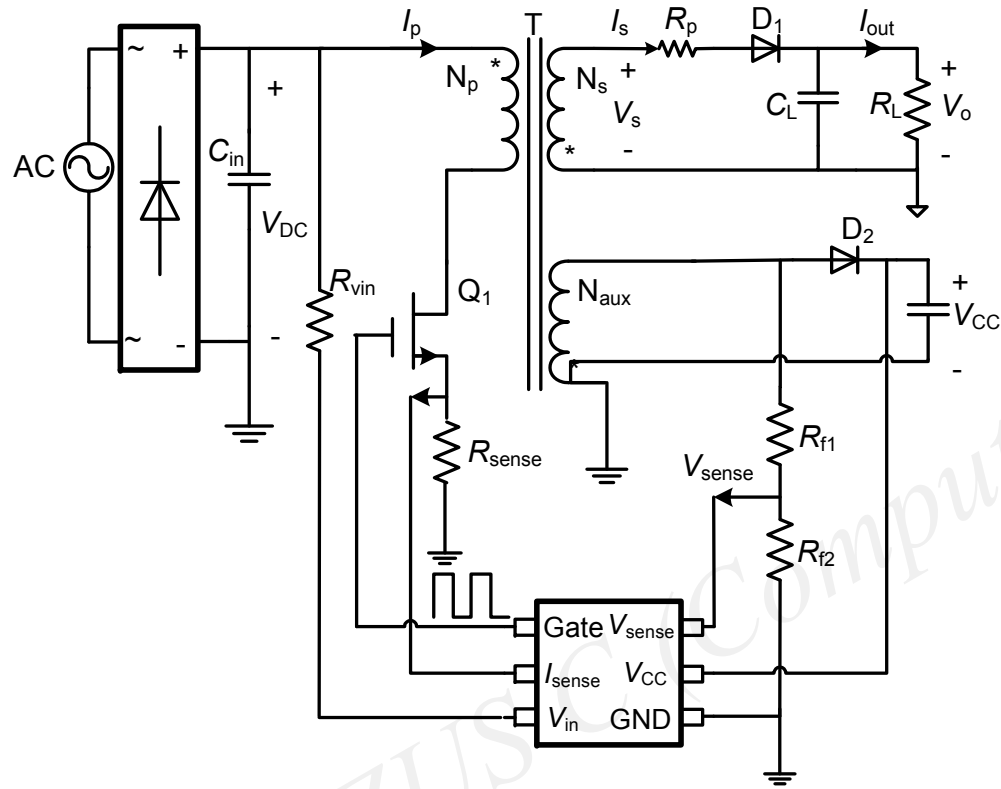

Primary-side feedback flyback with the proposed digital controller



Test board of the proposed controller

Output voltage and operation mode against different loads

R_L (Ω)	V_o (V)	Load (A)	Mode
100.0	5.68	0.057	PFM
20.0	5.64	0.282	PWM
17.6	5.60	0.318	PWM
14.0	5.60	0.400	PWM
11.0	5.55	0.500	CC
7.9	4.00	0.506	CC
4.4	2.20	0.500	CC