

Ming Yang, Ying-ming Li, Zhongfei(Mark) Zhang, 2014. Scientific articles recommendation with topic regression and relational matrix factorization. *Journal of Zhejiang University-SCIENCE C (Computers & Electronics)*, **15**(11):984-998.

[doi:[10.1631/jzus.C1300374](https://doi.org/10.1631/jzus.C1300374)]

Scientific articles recommendation with topic regression and relational matrix factorization

Key words: Matrix factorization, Probabilistic topic modeling,
Relational matrix factorization, Recommender system

Corresponding author: Ming Yang
E-mail: cauchym@zju.edu.cn

Introduction

- The existing recommendation methods may have trouble in making accurate predictions for users with few ratings
- The existing recommendation methods do not effectively support tasks that are specific to a certain research field
- There is no consideration for the relational structures

Design method (I)

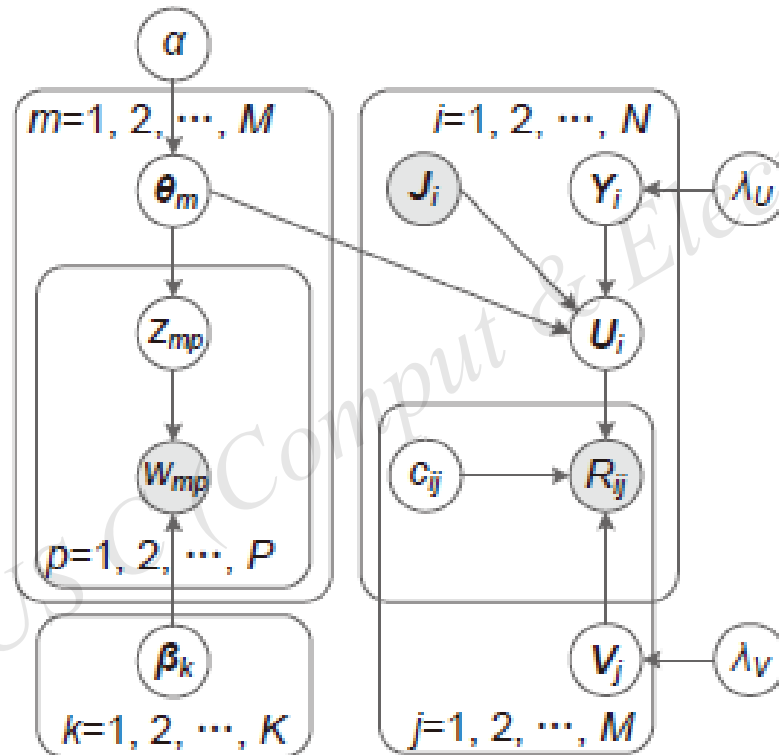

Graphical model of topic regression matrix factorization (tr-MF) model

Design method (II)

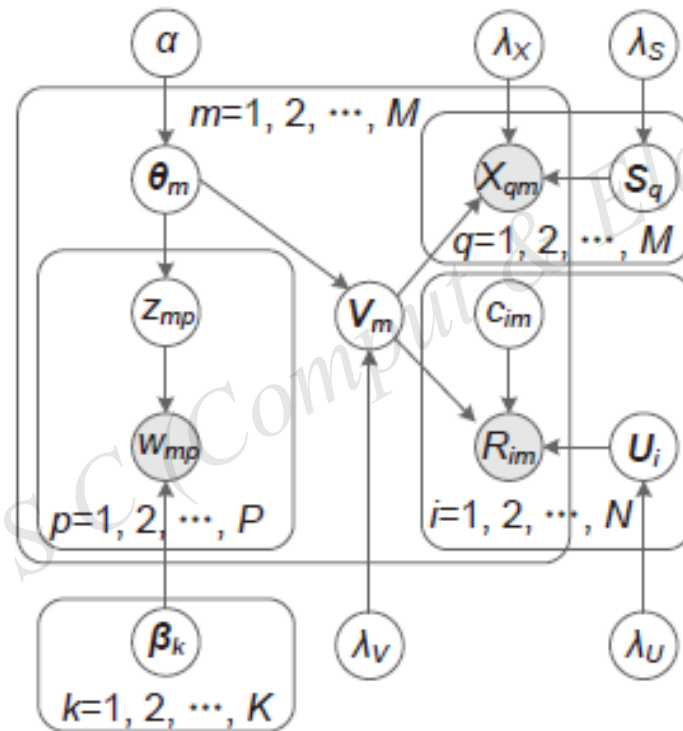

Graphical model of collaborative topic regression with relational matrix factorization (CTR-RMF) model

Design method (III)

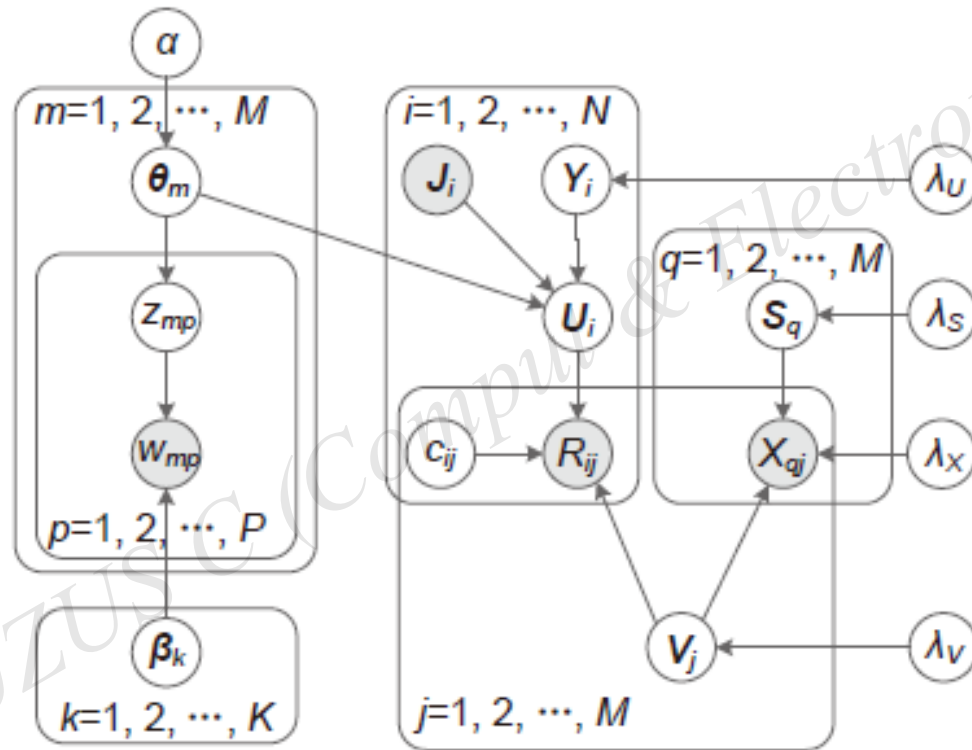

Graphical model of topic regression collective matrix factorization (tr-CMF) model

Evaluation

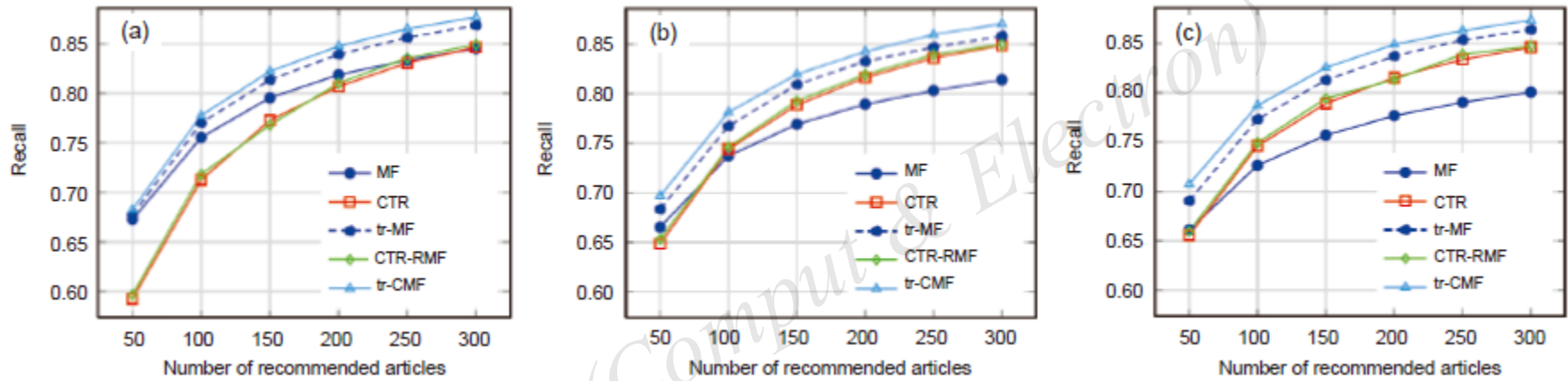

Comparison of the recall on predictions for different dimensionalities of the latent feature vectors: (a) $K=100$; (b) $K=200$; (c) $K=300$

Evaluation

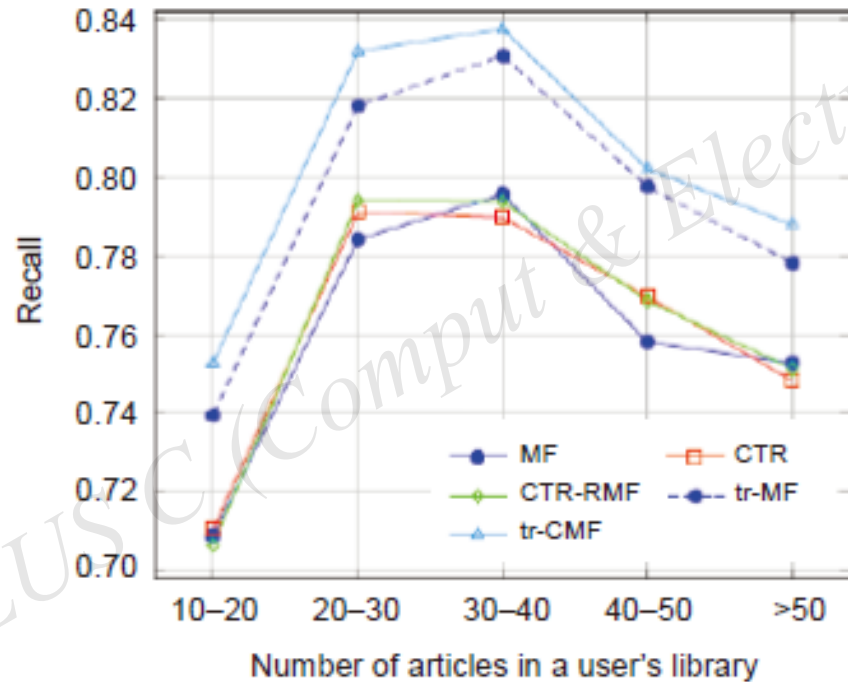

Comparison of the recalls on different users

Conclusions

- We first have developed a new model called tr-MF for recommending scientific articles to users
- Through incorporating the relational information, we further propose the CTR-RMF and tr-CMF for relational model training
- The proposed methods are compared with the state-of-the-art methods and show promising capability for supporting the task of recommending papers